

Super Fast Surface Mount Rectifiers

Reverse Voltage 200V to 1600V Forward Current 1.5A

YG10D thru YG10Y

Features

- For surface mounted application
- Low profile package
- Built-in stain relief, ideal for automatic placement
- Easy pick and place
- Glass passivated junction chip
- High temperature soldering: 250 °C/10 seconds at terminals
- Plastic material used carries UL flammability classification 94V-0

Mechanical Data

- Case: SMA/DO-214AC molded plastic
- Terminals: Pure tin plated, solderable per MIL-STD-750 method 2026
- Polarity: Indicated by cathode band
- Weight: 0.064 gram, 0.002 ounce

Outline



Ordering Information

Device	Package	Shipping	Marking
YG10D-0-T4-G	SMA (Pb-free lead plating and halogen-free package)	7500 pcs / Tape & Reel	YG10D
YG10G-0-T4-G			YG10G
YG10J-0-T4-G			YG10J
YG10K-0-T4-G			YG10K
YG10M-0-T4-G			YG10M
YG10Y-0-T4-G			YG10Y

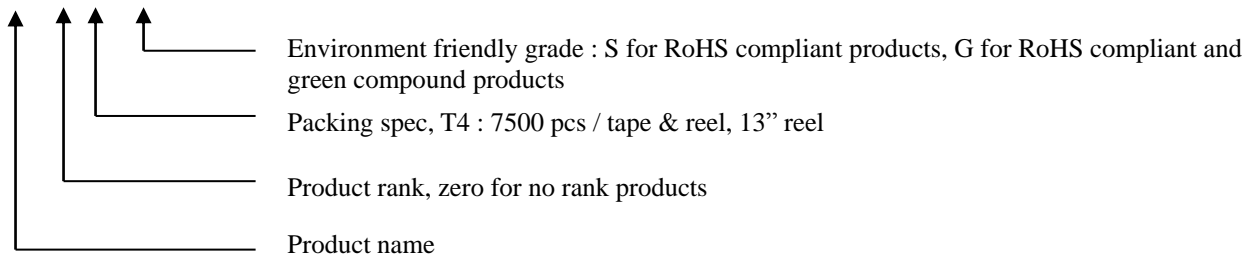

Maximum Ratings and Electrical Characteristics

(Rating at 25°C ambient temperature unless otherwise specified. Single phase, half wave, 60Hz, resistive or inductive load. For capacitive load, derate current by 20%.)

Parameter	Symbol	Type						Units
		YG10D	YG10G	YG10J	YG10K	YG10M	YG10Y	
Maximum repetitive peak reverse voltage	V_{RRM}	200	400	600	800	1000	1600	V
Maximum RMS voltage	V_{RMS}	140	280	420	560	700	1120	V
Maximum DC blocking voltage	V_R	200	400	600	800	1000	1600	V
Maximum instantaneous forward voltage, $I_F=1.5A$	V_F	1.15						V
Maximum average forward rectified current	$I_{F(AV)}$	1.5						A
Peak forward surge current @8.3ms single half sine wave superimposed on rated load (JEDEC method)	I_{FSM}	30						A
Maximum DC reverse current $V_R=V_{RRM}, T_A=25^\circ C$ $V_R=V_{RRM}, T_A=100^\circ C$	I_R	1 10						μA
Maximum reverse recovery time (Note 1)	t_{rr}	4						us
Typical thermal resistance (Note 2)	$R_{\theta JA}$ $R_{\theta JC}$	125 40						$^\circ C/W$
Non-Repetitive Peak Reverse Avalanche Energy at 25°C, $I_{AS}=1A / L=10mH$	E_{as}	20						mJ
Storage temperature range	T_{STG}	-55 ~ +150						$^\circ C$
Operating junction temperature range	T_J	-55 ~ +150						$^\circ C$

Note: 1.Reverse recovery time conditions : $I_F=0.5A, I_R=1A, I_{RR}=0.25A$
 2.P.C.B. mounted on 0.2"×0.2"(5.0mm×5.0mm) copper pad area.

Recommended soldering footprint

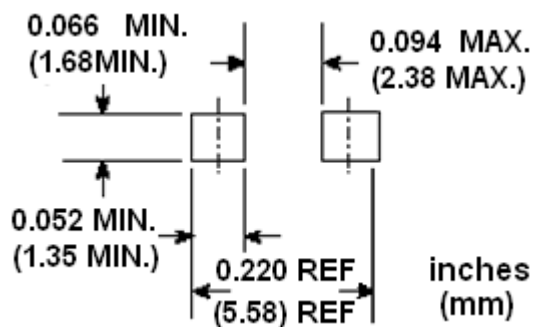

Characteristic Curves

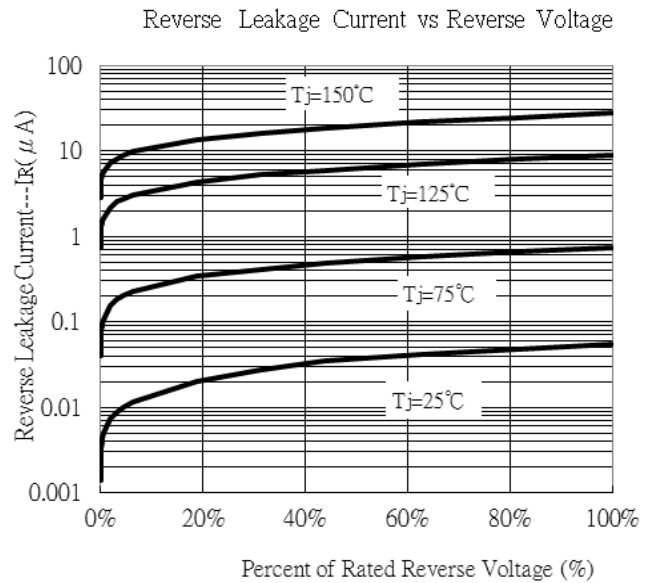
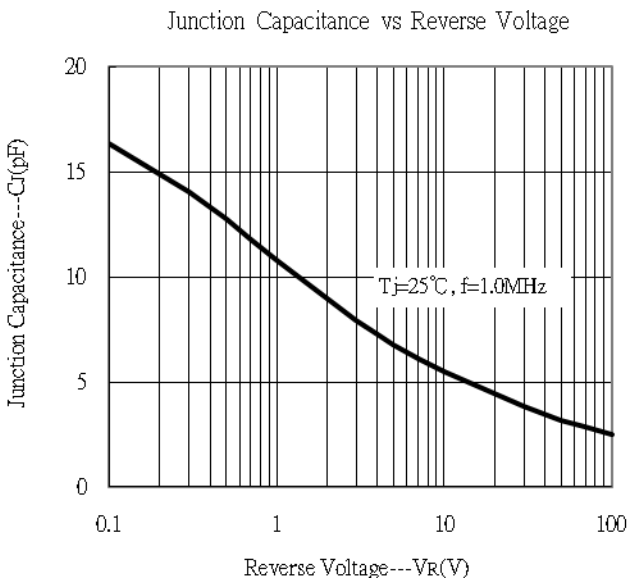
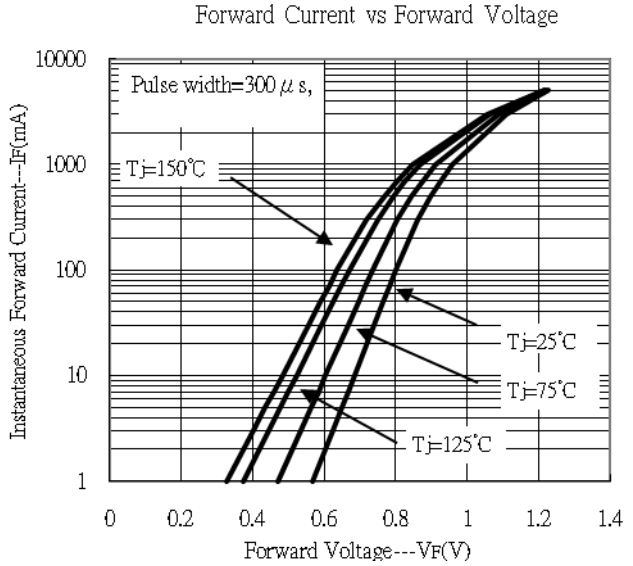
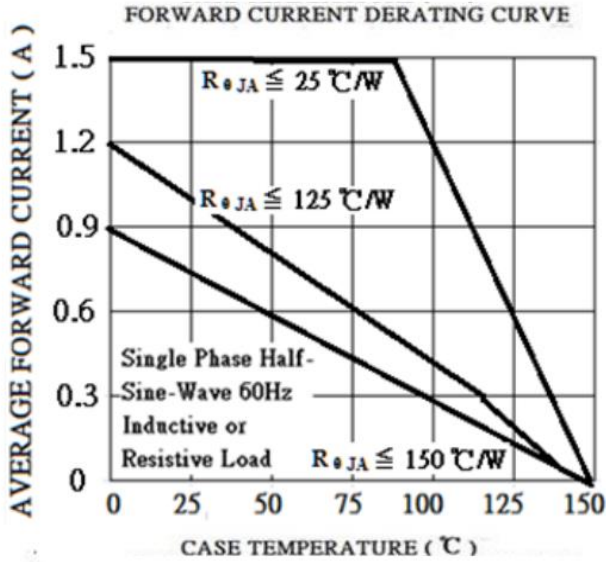

Reel Dimension

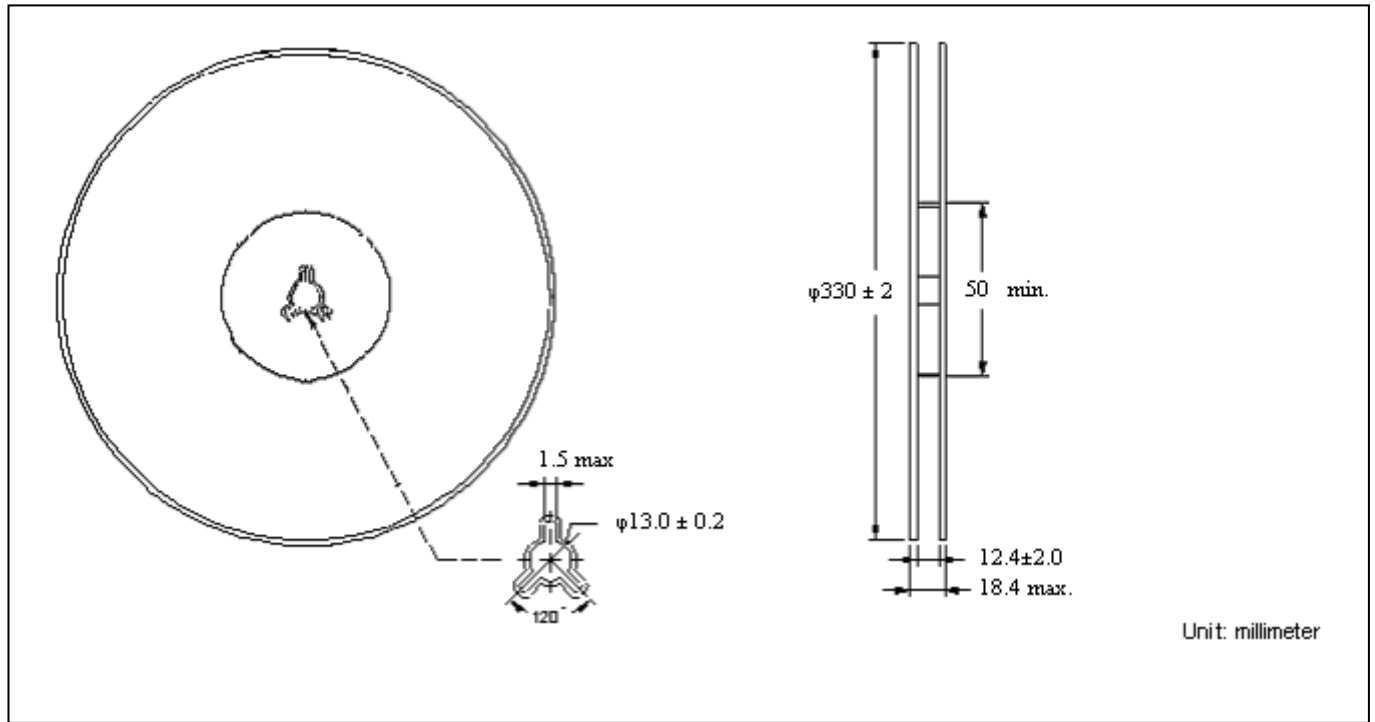

Carrier Tape Dimension

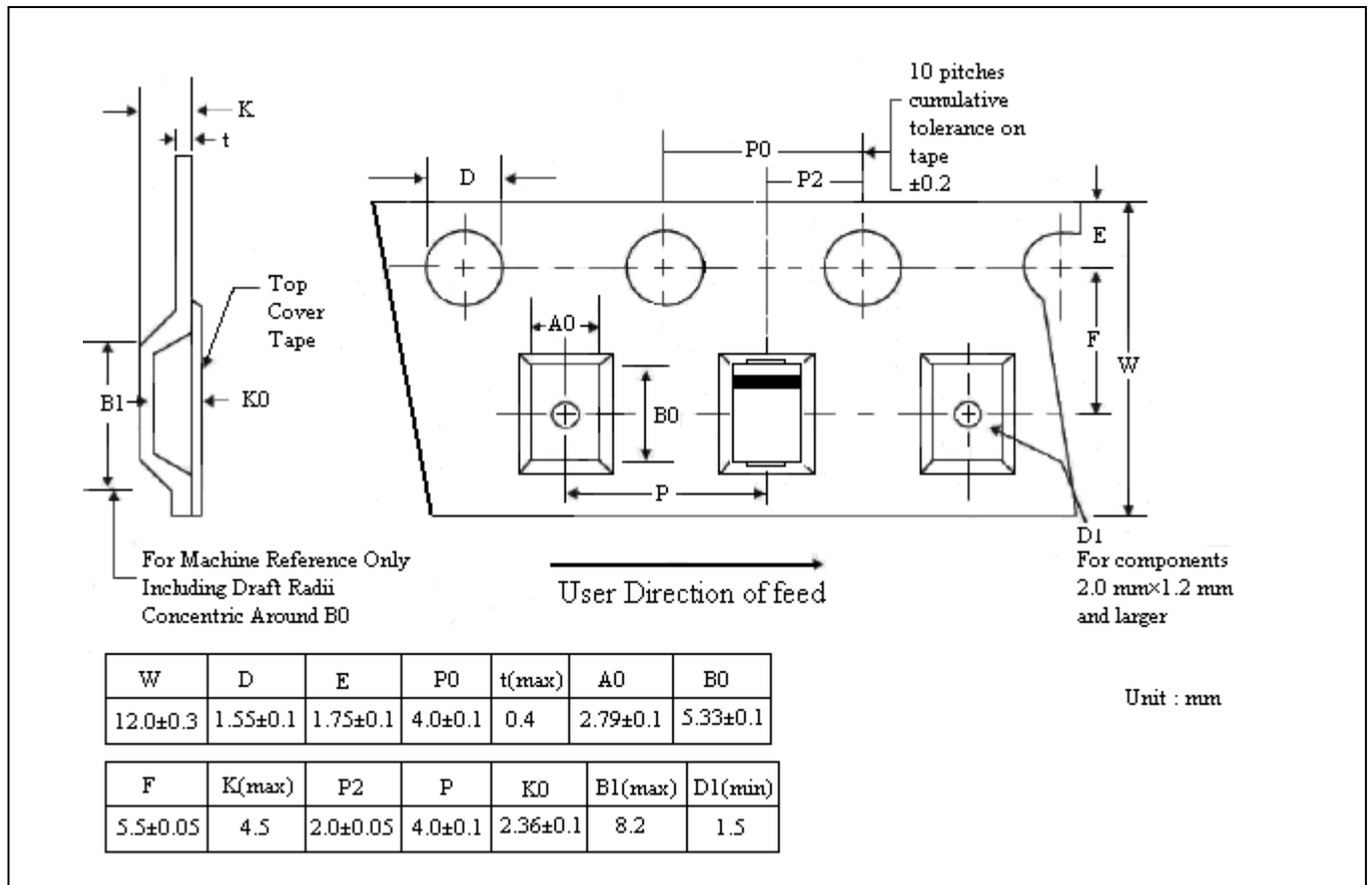

Recommended wave soldering condition

Product	Peak Temperature	Soldering Time
Pb-free devices	260 +0/-5 °C	5 +1/-1 seconds

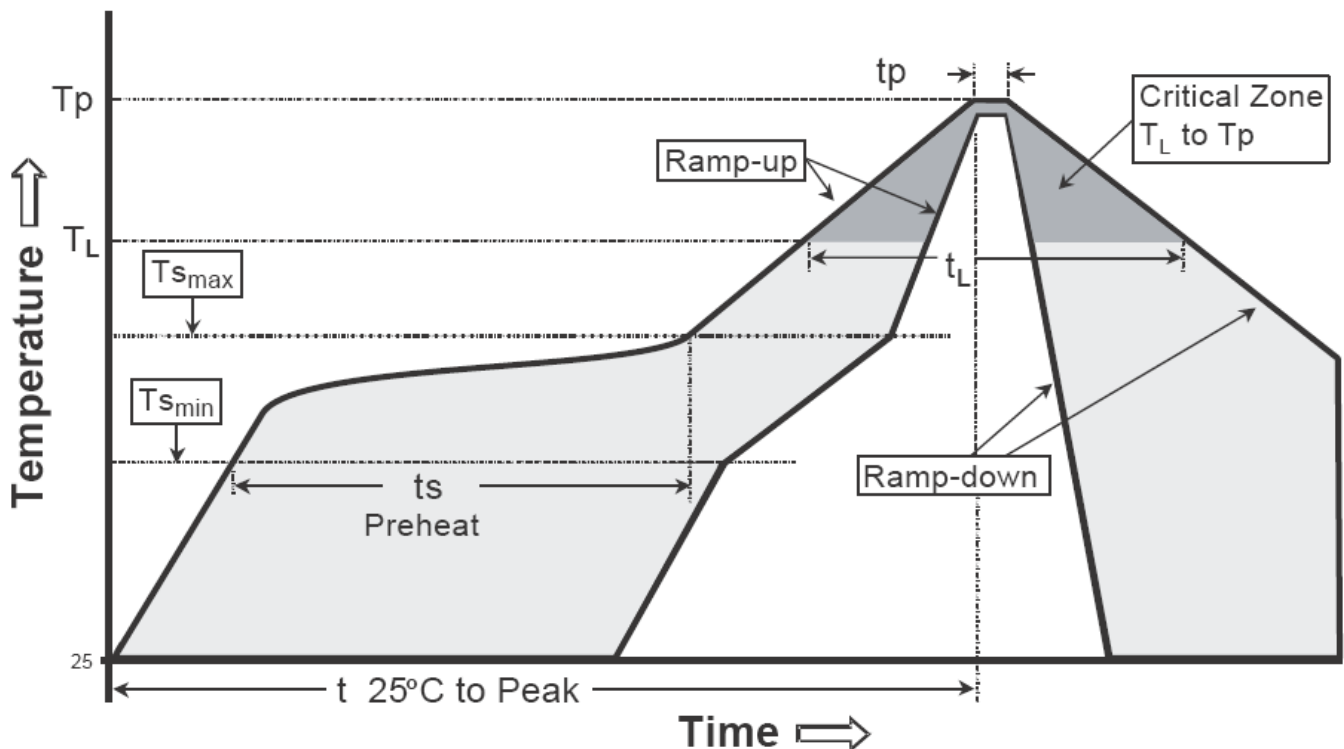
Recommended temperature profile for IR reflow

Profile feature	Sn-Pb eutectic Assembly	Pb-free Assembly
Average ramp-up rate (T _{smax} to T _p)	3°C/second max.	3°C/second max.
Preheat		
-Temperature Min(T _{s min})	100°C	150°C
-Temperature Max(T _{s max})	150°C	200°C
-Time(t _{s min} to t _{s max})	60-120 seconds	60-180 seconds
Time maintained above:		
-Temperature (T _L)	183°C	217°C
- Time (t _L)	60-150 seconds	60-150 seconds
Peak Temperature(T _p)	240 +0/-5 °C	260 +0/-5 °C
Time within 5°C of actual peak temperature(tp)	10-30 seconds	20-40 seconds
Ramp down rate	6°C/second max.	6°C/second max.
Time 25 °C to peak temperature	6 minutes max.	8 minutes max.

Note : All temperatures refer to topside of the package, measured on the package body surface.

SMA/DO-214AC Dimension

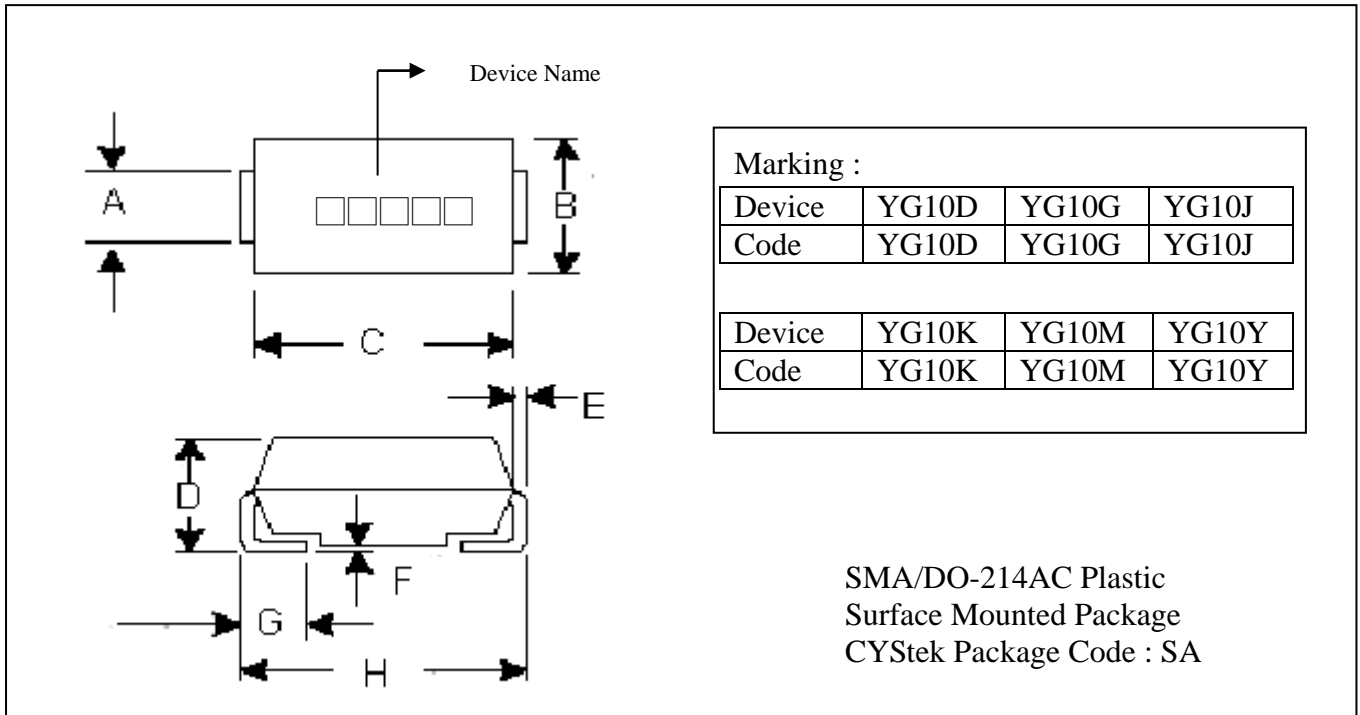

DIM	Inches		Millimeters		DIM	Inches		Millimeters	
	Min.	Max.	Min.	Max.		Min.	Max.	Min.	Max.
A	0.052	0.062	1.32	1.60	E	0.006	0.012	0.15	0.31
B	0.098	0.114	2.50	2.90	F	0.002	0.008	0.05	0.20
C	0.154	0.181	3.90	4.60	G	0.030	0.060	0.76	1.52
D	0.067	0.098	1.70	2.50	H	0.188	0.208	4.80	5.28

Notes : 1.Controlling dimension : millimeters.
 2.Maximum lead thickness includes lead finish thickness, and minimum lead thickness is the minimum thickness of base material.
 3.If there is any question with packing specification or packing method, please contact your local CYStek sales office.

Material :

- Lead : Pure tin plated.
- Mold Compound : Epoxy resin family, flammability solid burning class:UL94V-0.

Important Notice:

- All rights are reserved. Reproduction in whole or in part is prohibited without the prior written approval of CYStek.
- CYStek reserves the right to make changes to its products without notice.
- CYStek **semiconductor products are not warranted to be suitable for use in Life-Support Applications, or systems.**
- CYStek assumes no liability for any consequence of customer product design, infringement of patents, or application assistance.