

16Amp. Ultrafast Plastic Rectifiers

MUR1660FP

$I_{F(AV)}$	2 × 8A
V_{RRM}	600V
I_{FSM}	100A
trr	50ns
T_j	175°C
$V_{F(MAX)}$	1.5V

Features

- 175°C operating junction temperature
- Low leakage current
- Low switching loss, high efficiency
- High forward surge capability
- Insulating package, insulating voltage=2500V AC
- High temperature soldering guaranteed : 260°C/40s, 0.25”(6.35mm) from case
- Pb-free lead plating package

Mechanical Data

- Case: TO-220FP molded plastic
- Mounting Position: Any
- Weight: 2.2 grams, 0.078 ounce approximately
- Terminals: Pure tin plated, solderable per MIL-STD-750 method 2026
- Epoxy: UL 94V-0 rate flame retardant
- Mounting torque: 5 in.-lb. maximum

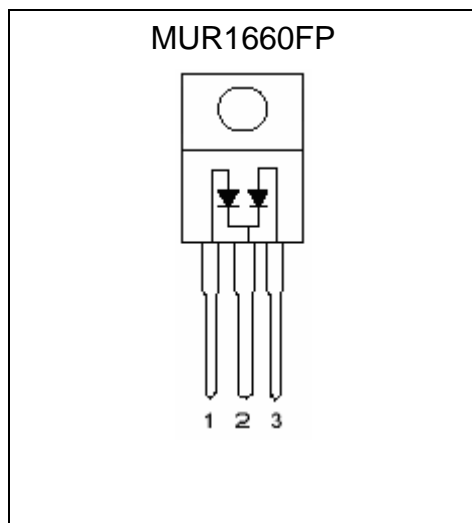
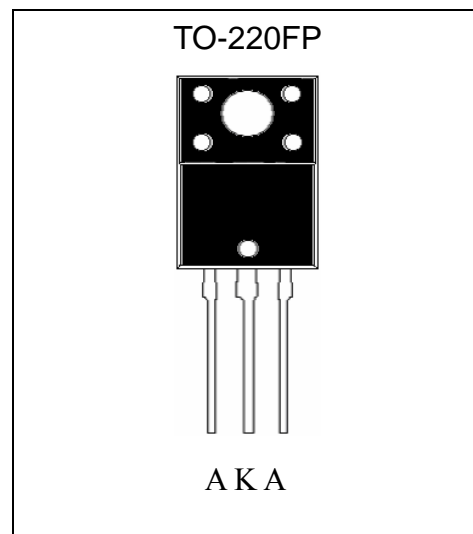
Equivalent Circuit

Outline

**Maximum Ratings and Electrical Characteristics (Per Diode Leg)**

(Rating at 25°C ambient temperature unless otherwise specified. Single phase, half wave, 60Hz, resistive or inductive load. For capacitive load, derate current by 20%.)

Parameter	Symbol	Min.	Typ.	Max.	Units
Maximum Recurrent peak reverse voltage	V_{RRM}			600	V
Maximum RMS voltage	V_{RMS}			420	V
Maximum DC blocking voltage	V_{DC}			600	V
Maximum instantaneous forward voltage at	$I_F=8A, T_C=25^\circ C$		1.23	1.5	V
	$I_F=8A, T_C=150^\circ C$		1.06	1.3	
	$I_F=16A, T_C=25^\circ C$		1.41	1.8	
	$I_F=16A, T_C=150^\circ C$		1.35	1.7	
Maximum Average forward rectified current @ $T_C=100^\circ C$	Per Diode			8	A
	Per Device			16	
Non-repetitive peak forward surge current @ 8.3ms single half sine wave superimposed on rated load (JEDEC method)	I_{FSM}			100	A
Maximum instantaneous reverse current at	$V_R=600V, T_C=25^\circ C$			10	μA
	$V_R=600V, T_C=125^\circ C$			100	
Maximum reverse recovery time	$I_F=1A, V_R=30V, dI_F/dt=100A/\mu s$			50	ns
Typical junction capacitance @ $f=1MHz$ and applied 4V reverse voltage	C_J		50		pF
Isolation voltage from terminal to heatsink, $t=1$ minute	V_{AC}	2500			V
Storage temperature range	T_{stg}	-65		+175	$^\circ C$
Operating junction temperature range	T_J	-65		+175	$^\circ C$

Thermal Data

Parameter	Symbol	Value	Unit
Maximum Thermal Resistance, Junction-to-case	$R_{th,j-c}$	5	$^\circ C/W$
Maximum Thermal Resistance, Junction-to-ambient	$R_{th,j-a}$	60	$^\circ C/W$
Lead Temperature for Soldering Purposes : 1/8" from Case for 5 seconds	T_L	300	$^\circ C$

Ordering Information

Device	Package	Shipping
MUR1660FP	TO-220FP (RoHS compliant package)	50 pcs / Tube, 40 Tubes/Box

Typical Characteristics

Forward Current Derating Curve

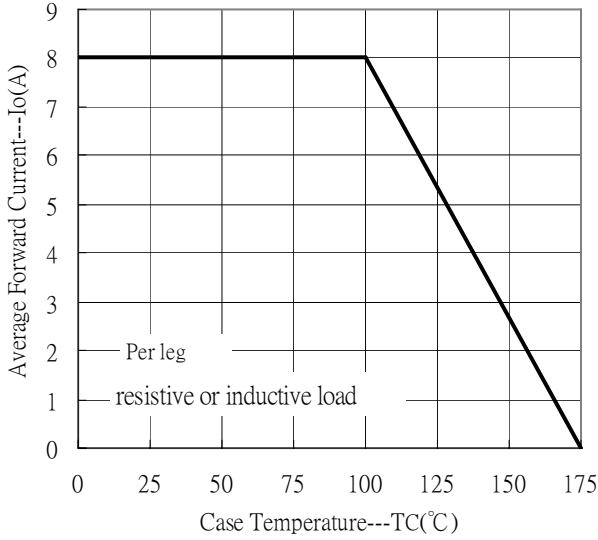

Forward Current vs Forward Voltage

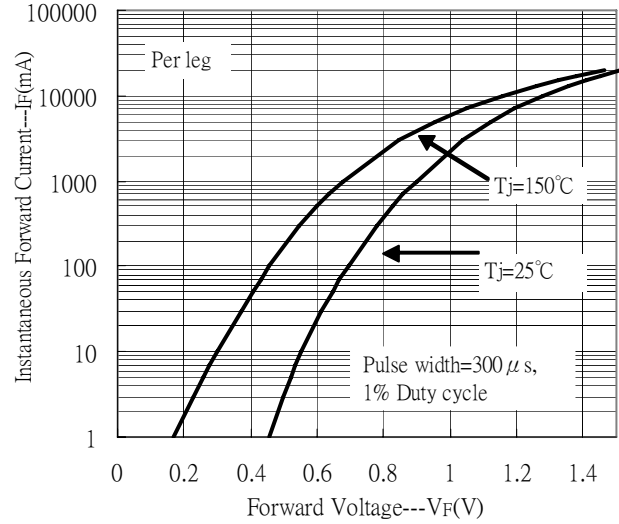

Reverse Leakage Current vs Reverse Voltage

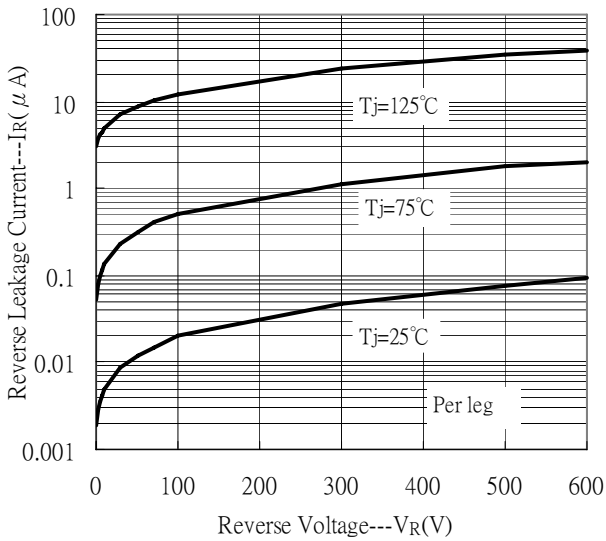

Junction Capacitance vs Reverse Voltage

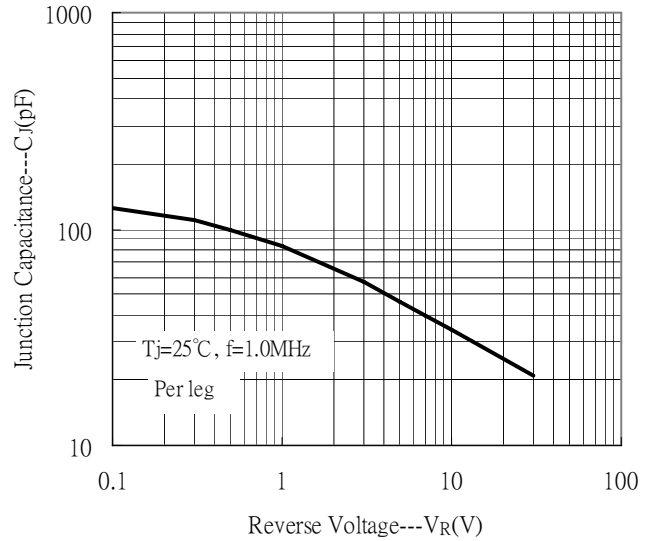

TO-220FP Dimension

3-Lead TO-220FP Plastic Package
 CYStek Package Code: FP

Style: Pin 1.Anode 2.Cathode 3.Anode

*Typical

DIM	Inches		Millimeters		DIM	Inches		Millimeters	
	Min.	Max.	Min.	Max.		Min.	Max.	Min.	Max.
A	0.171	0.183	4.35	4.65	G	0.246	0.258	6.25	6.55
A1	0.051 REF		1.300 REF		H	0.138 REF		3.50	REF
A2	0.112	0.124	2.85	3.15	H1	0.055 REF		1.40	REF
A3	0.102	0.110	2.60	2.80	H2	0.256	0.272	6.50	6.90
b	0.020	0.030	0.50	0.75	J	0.031 REF		0.80	REF
b1	0.031	0.041	0.80	1.05	K	0.020		0.50	REF
b2	0.047 REF		1.20 REF		L	1.102	1.118	28.00	28.40
c	0.020	0.030	0.500	0.750	L1	0.043	0.051	1.10	1.30
D	0.396	0.404	10.06	10.26	L2	0.036	0.043	0.92	1.08
E	0.583	0.598	14.80	15.20	M	0.067 REF		1.70	REF
e	0.100 *		2.54*		N	0.012	REF	0.30	REF
F	0.106 REF		2.70 REF						

- Notes: 1.Controlling dimension: millimeters.
 2.Maximum lead thickness includes lead finish thickness, and minimum lead thickness is the minimum thickness of base material.
 3.If there is any question with packing specification or packing method, please contact your local CYStek sales office.

Material:

- Lead: Pure tin plated.
- Mold Compound: Epoxy resin family, flammability solid burning class: UL94V-0.

Important Notice:

- All rights are reserved. Reproduction in whole or in part is prohibited without the prior written approval of CYStek.
- CYStek reserves the right to make changes to its products without notice.
- CYStek **semiconductor products are not warranted to be suitable for use in Life-Support Applications, or systems.**
- CYStek assumes no liability for any consequence of customer product design, infringement of patents, or application assistance.