

**N-Channel Enhancement Mode Power MOSFET**

# MTB10KT40A3

**Features**

- Low Gate Charge
- Fast Switching Characteristic

$BV_{DSS}$	400V
$I_D @ V_{GS}=10V, T_A=25^\circ C$	0.22A
$R_{DS(ON) typ. @ V_{GS}=10V, I_D=0.12A}$	10Ω
$R_{DS(ON) typ. @ V_{GS}=4.5V, I_D=0.12A}$	10Ω

**Equivalent Circuit**

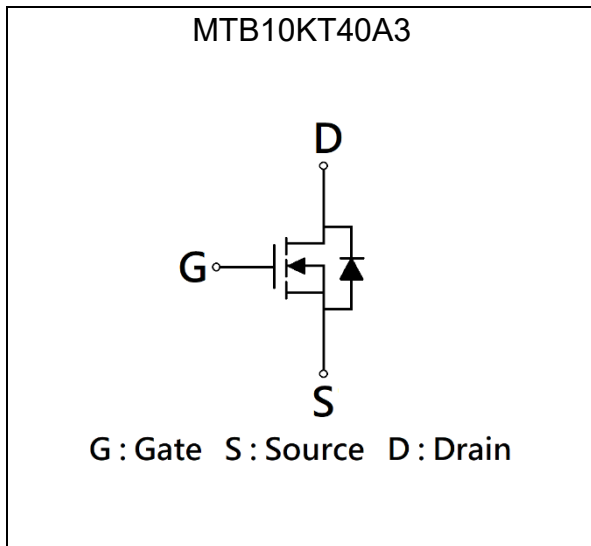

**Outline**

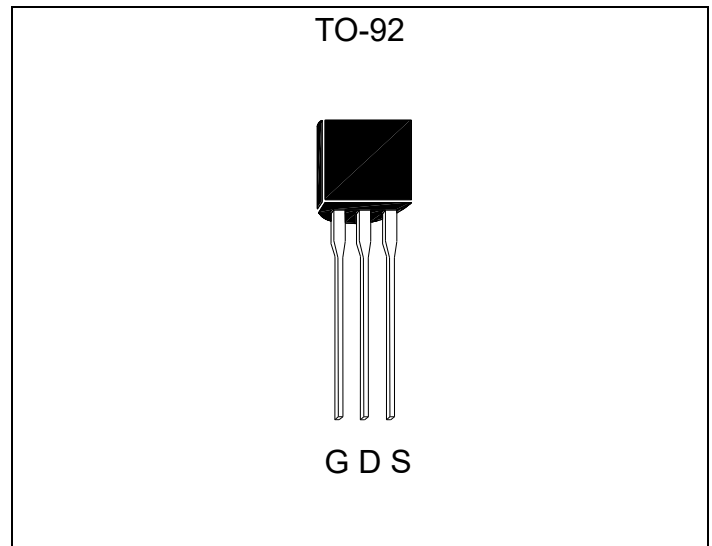

**Ordering Information**

Device	Package	Shipping
MTB10KT40A3-0-TB-G	TO-92 (Pb-free lead plating and RoHS compliant package)	2000 pcs / Tape & Box
MTB10KT40A3-0-BK-G		1000 pcs/ bag, 10 bags/box, 10 boxes/carton

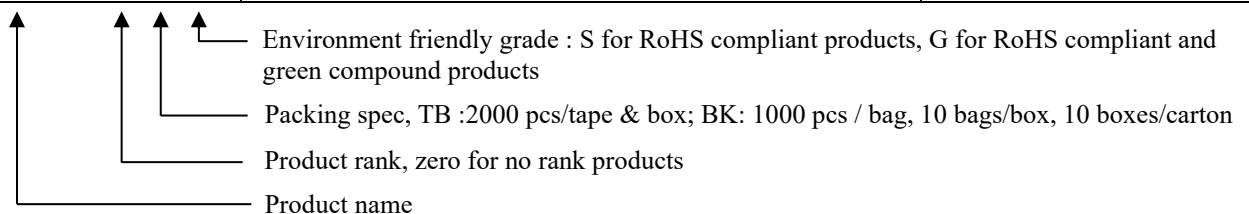



### Absolute Maximum Ratings (T<sub>A</sub>=25°C)

Parameter	Symbol	Limits	Unit	
Drain-Source Voltage	V <sub>DS</sub>	400	V	
Gate-Source Voltage	V <sub>GS</sub>	±20		
Continuous Drain Current @ V <sub>GS</sub> =10V, T <sub>A</sub> =25°C	I <sub>D</sub>	0.22	A	
Continuous Drain Current @ V <sub>GS</sub> =10V, T <sub>A</sub> =70°C		0.18		
Pulsed Drain Current	I <sub>DM</sub>	0.66		
Continuous Body Diode Forward Current @ T <sub>A</sub> =25°C	I <sub>S</sub>	0.22		
Pulsed Body Diode Forward Current @ T <sub>A</sub> =25°C	I <sub>SM</sub>	0.66		
Total Power Dissipation	P <sub>D</sub>	T <sub>A</sub> =25°C		1.6
		T <sub>A</sub> =70°C	1	
Operating Junction and Storage Temperature Range	T <sub>J</sub> , T <sub>stg</sub>	-55~+150	°C	

### Thermal Data

Parameter	Symbol	Steady State	Unit
Thermal Resistance, Junction-to-ambient	R <sub>θJA</sub>	77	°C/W

Note:

- \*a. The value of R<sub>θJA</sub> is measured with the device mounted on 1 in<sup>2</sup> FR-4 board with 2 oz. copper, in a still air environment with T<sub>A</sub>=25°C. The power dissipation P<sub>D</sub> is based on R<sub>θJA</sub> and the maximum allowed junction temperature of 150°C. The value in any given application depends on the user's specific board design.
- \*b. Repetitive rating, pulse width limited by junction temperature T<sub>J(MAX)</sub>=150°C. Ratings are based on low frequency and low duty cycles to keep initial T<sub>J</sub>=25°C.



**Electrical Characteristics (T<sub>A</sub>=25°C, unless otherwise specified)**

Symbol	Min.	Typ.	Max.	Unit	Test Conditions
<b>Static</b>					
BV <sub>DSS</sub>	400	-	-	V	V <sub>GS</sub> =0V, I <sub>D</sub> =250μA
V <sub>GS(th)</sub>	1	-	2.5		V <sub>DS</sub> =V <sub>GS</sub> , I <sub>D</sub> =250μA
G <sub>FS</sub>	-	0.65	-	S	V <sub>DS</sub> =10V, I <sub>D</sub> =0.1A
I <sub>GSS</sub>	-	-	±100	nA	V <sub>GS</sub> =±20V, V <sub>DS</sub> =0V
I <sub>DSS</sub>	-	-	1	μA	V <sub>DS</sub> =320V, V <sub>GS</sub> =0V
R <sub>DS(ON)</sub>	-	10	13	Ω	V <sub>GS</sub> =10V, I <sub>D</sub> =120mA
	-	10	14		V <sub>GS</sub> =4.5V, I <sub>D</sub> =120mA
<b>Dynamic</b>					
C <sub>iss</sub>	-	79	-	pF	V <sub>DS</sub> =200V, V <sub>GS</sub> =0V, f=1MHz
C <sub>oss</sub>	-	8	-		
C <sub>rss</sub>	-	6	-		
R <sub>g</sub>	-	5.2	-	Ω	f=1MHz
Q <sub>g</sub> *1, 2	-	1.9	-	nC	V <sub>DS</sub> =200V, I <sub>D</sub> =0.2A, V <sub>GS</sub> =4.5V
Q <sub>g</sub> *1, 2	-	3.5	-		
Q <sub>gs</sub> *1, 2	-	0.7	-		
Q <sub>gd</sub> *1, 2	-	0.7	-		
t <sub>d(ON)</sub> *1, 2	-	3.3	-	ns	V <sub>DS</sub> =200V, I <sub>D</sub> =0.12A, V <sub>GS</sub> =10V, R <sub>GS</sub> =25Ω
t <sub>r</sub> *1, 2	-	7	-		
t <sub>d(OFF)</sub> *1, 2	-	51	-		
t <sub>f</sub> *1, 2	-	49	-		
<b>Source-Drain Diode</b>					
V <sub>SD</sub> *1	-	0.75	1.2	V	I <sub>S</sub> =0.1A, V <sub>GS</sub> =0V
t <sub>rr</sub>	-	77	-	ns	I <sub>F</sub> =0.5A, dI <sub>F</sub> /dt=100A/μs
Q <sub>rr</sub>	-	59	-	nC	

Note:

\*1. Pulse Test : Pulse Width ≤300μs, Duty Cycle≤2%

\*2. Independent of operating temperature

## Typical Characteristics

Typical Output Characteristics

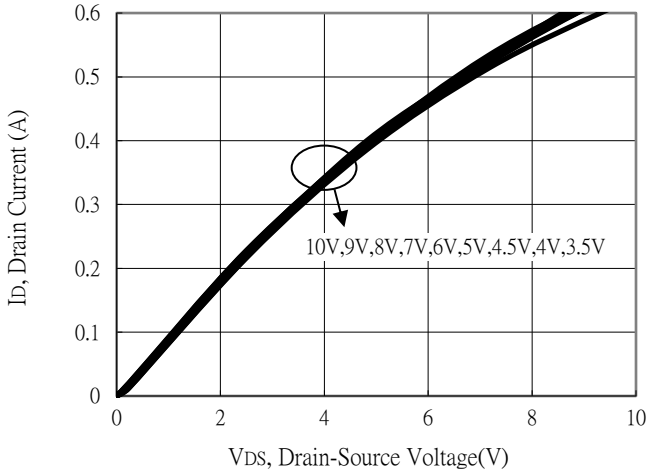

Breakdown Voltage vs Ambient Temperature

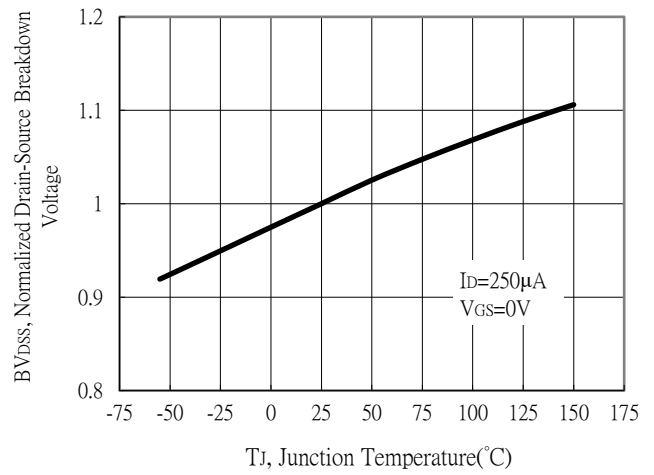

Static Drain-Source On-State resistance vs Drain Current

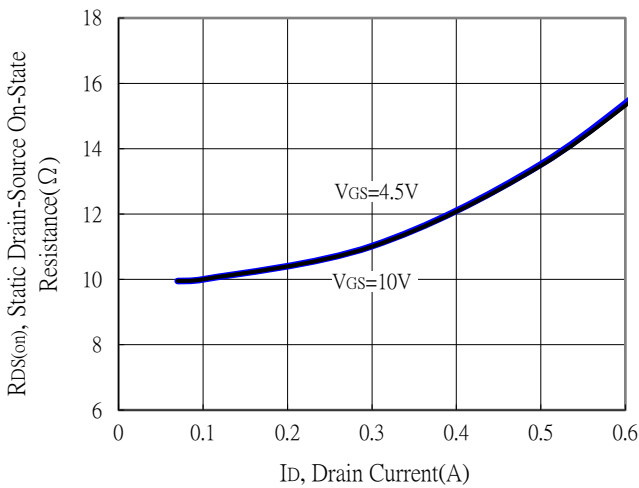

Body Diode Current vs Source-Drain Voltage

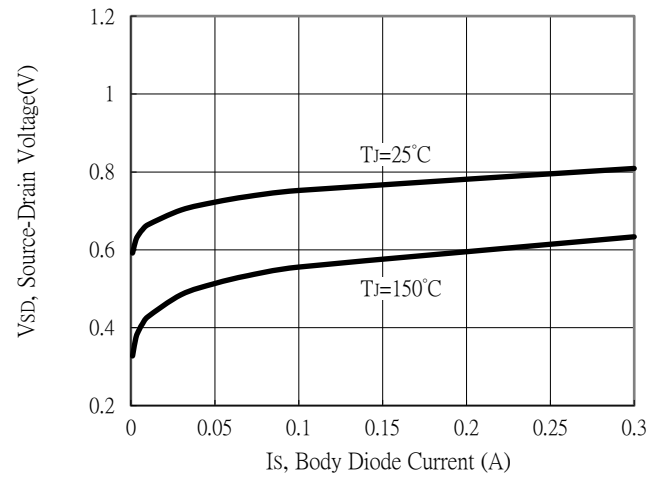

Static Drain-Source On-State Resistance vs Gate-Source Voltage

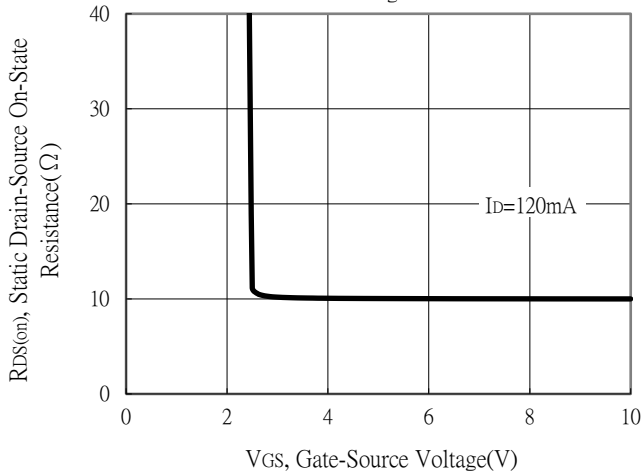

Drain-Source On-State Resistance vs Junction Temperature

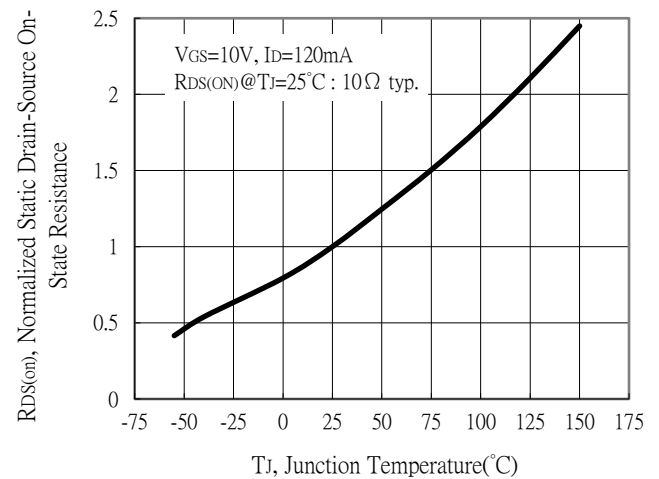



**Typical Characteristics (Cont.)**

Capacitance vs Drain-to-Source Voltage

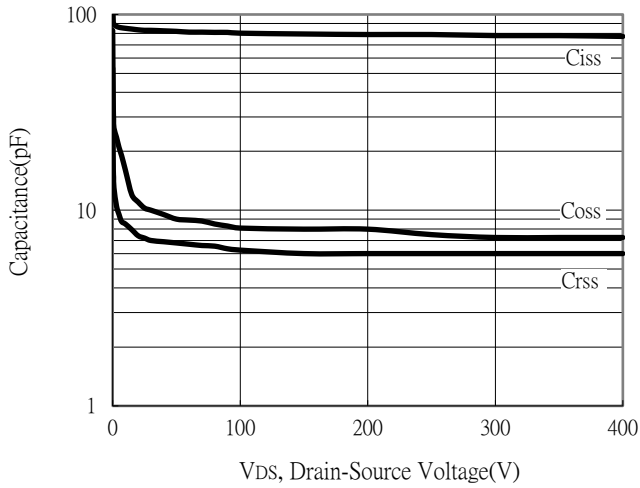

Threshold Voltage vs Junction Temperature

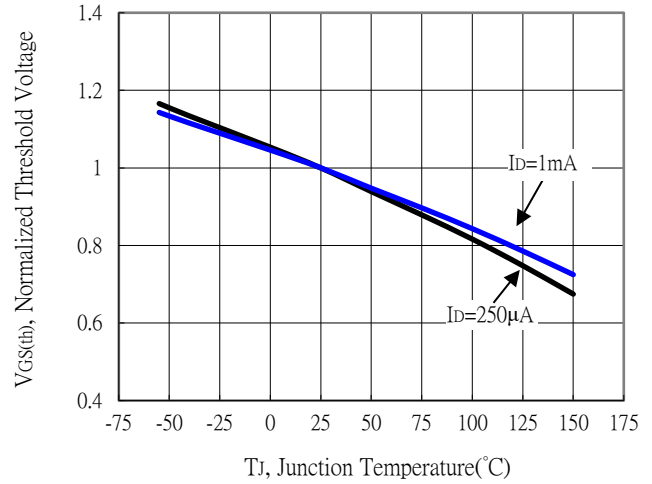

Forward Transfer Admittance vs Drain Current

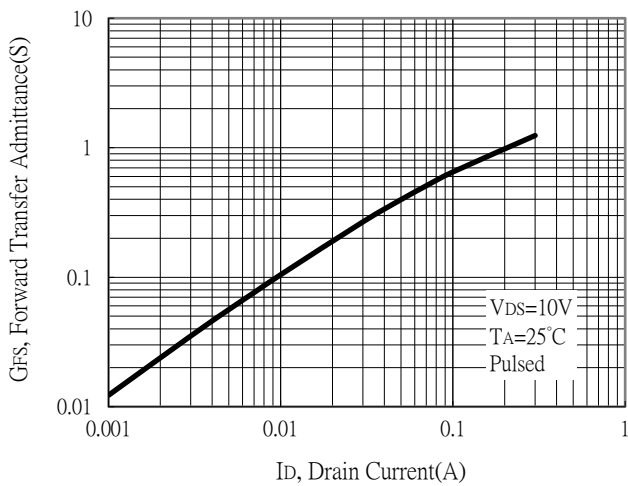

Gate Charge Characteristics

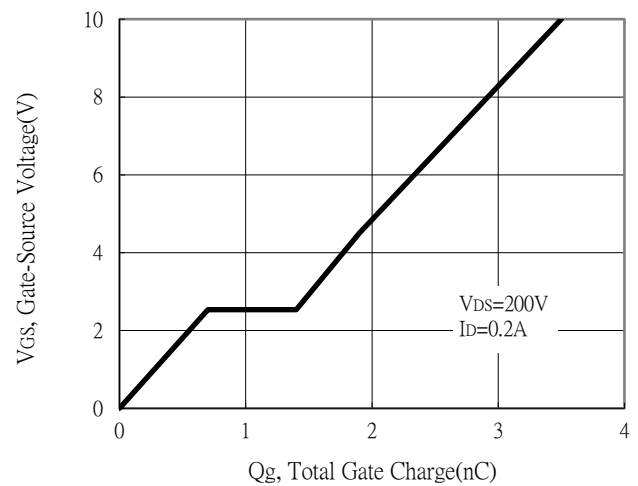

Maximum Safe Operating Area

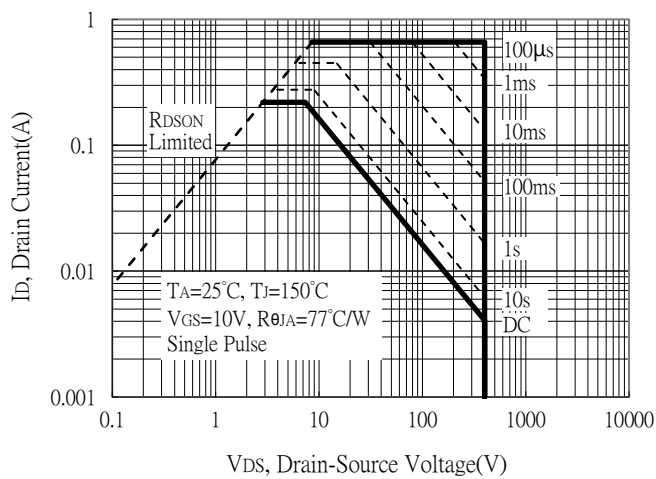

Maximum Drain Current vs Junction Temperature

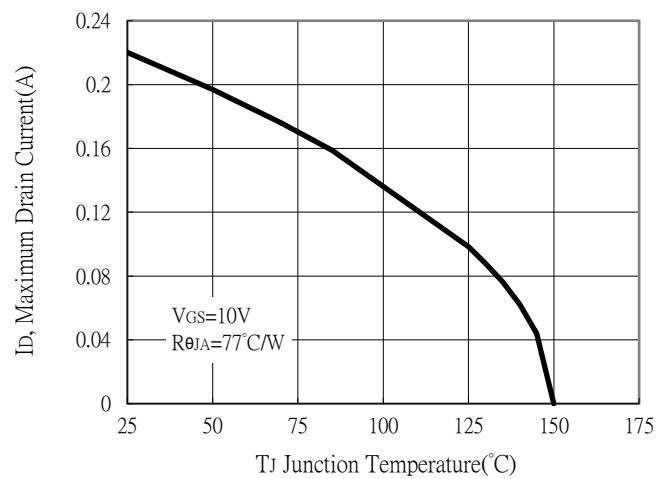

**Typical Characteristics (Cont.)**

Single Pulse Power Rating, Junction to Ambient

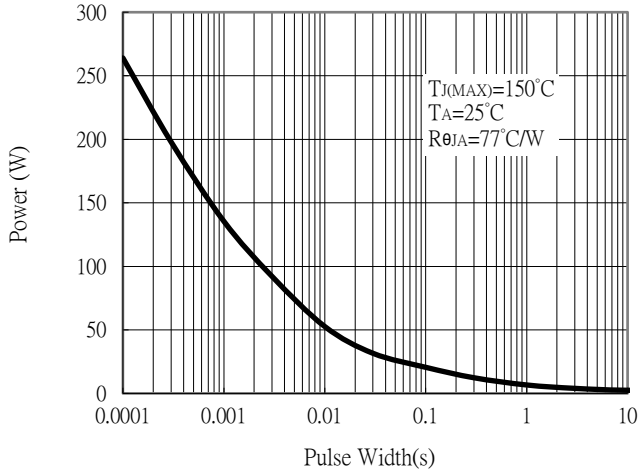

Transient Thermal Response Curves

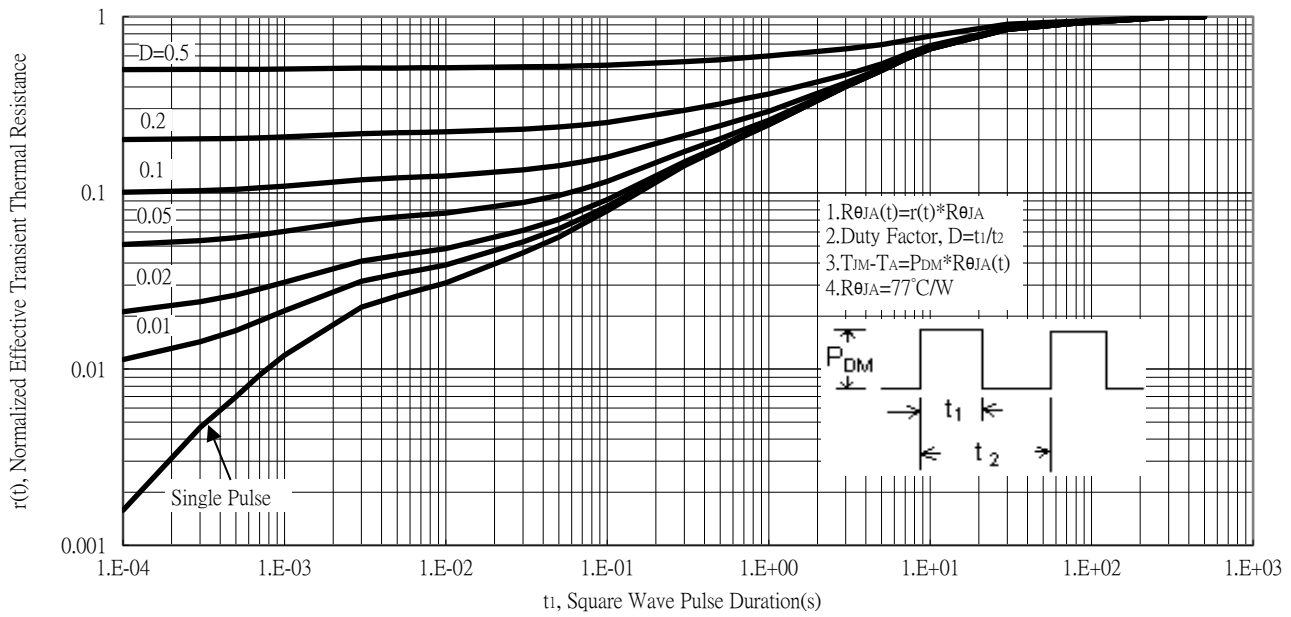

**TO-92 Taping Outline**

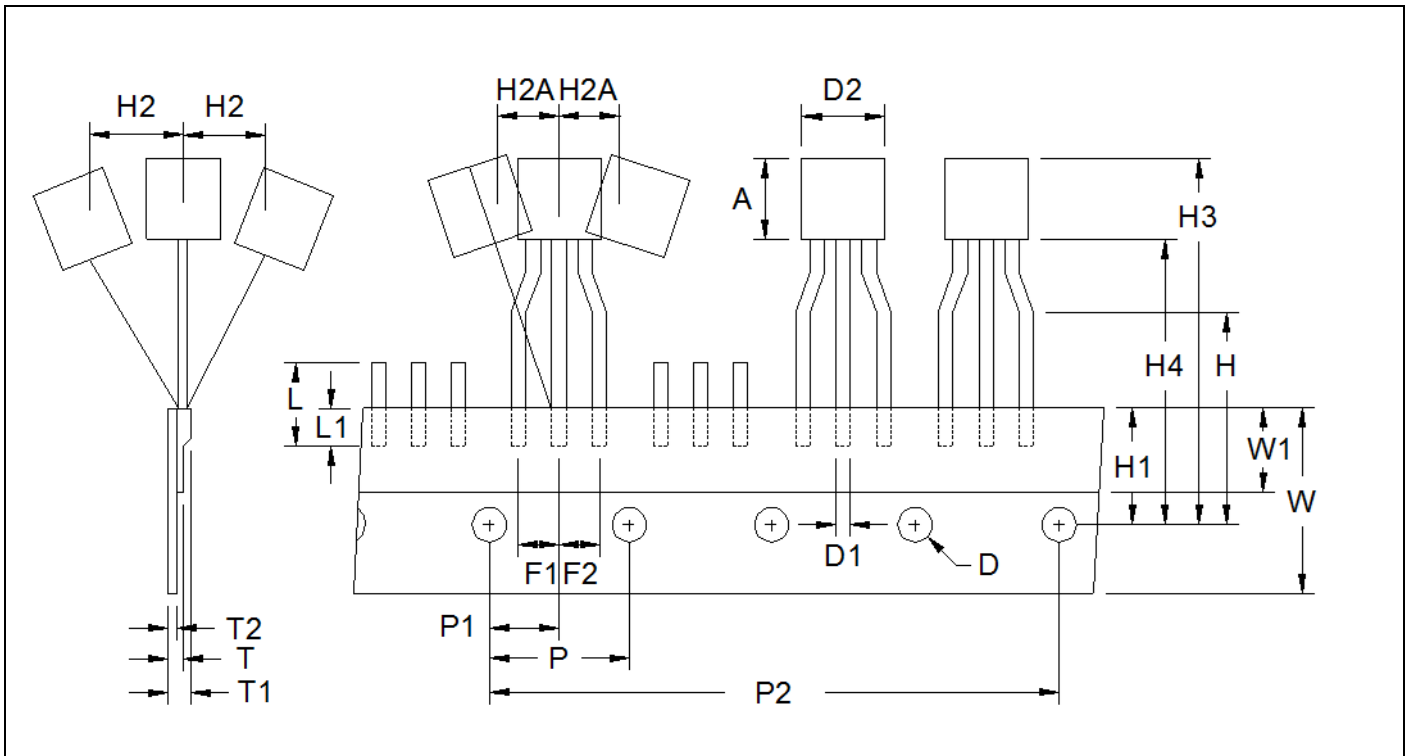

DIM	Item	Millimeters	
		Min.	Max.
A	Component body height	4.33	4.83
D	Tape Feed Diameter	3.80	4.20
D1	Lead Diameter	0.36	0.53
D2	Component Body Diameter	4.33	4.83
F1,F2	Component Lead Pitch	2.40	2.90
F1,F2	F1-F2	-	±0.3
H	Height Of Seating Plane	15.50	16.50
H1	Feed Hole Location	8.50	9.50
H2	Front To Rear Deflection	-	1
H2A	Deflection Left Or Right	-	1
H3	Component Height	-	27
H4	Feed Hole To Bottom Of Component	-	21
L	Lead Length After Component Removal	-	11
L1	Lead Wire Enclosure	2.50	-
P	Feed Hole Pitch	12.50	12.90
P1	Center Of Seating Plane Location	5.95	6.75
P2	4 Feed Hole Pitch	50.30	51.30
T	Over All Tape Thickness	-	0.55
T1	Total Taped Package Thickness	-	1.42
T2	Carrier Tape Thickness	0.36	0.68
W	Tape Width	17.50	19.00
W1	Adhesive Tape Width	5.00	7.00
-	20 pcs Pitch	253	255

**Recommended wave soldering condition**

Product	Peak Temperature	Soldering Time
Pb-free devices	260 +0/-5 °C	5 +1/-1 seconds

**Recommended temperature profile for IR reflow**



Profile feature	Sn-Pb eutectic Assembly	Pb-free Assembly
Average ramp-up rate (T <sub>smax</sub> to T <sub>p</sub> )	3°C/second max.	3°C/second max.
Preheat		
-Temperature Min(T <sub>s min</sub> )	100°C	150°C
-Temperature Max(T <sub>s max</sub> )	150°C	200°C
-Time(t <sub>s min</sub> to t <sub>s max</sub> )	60-120 seconds	60-180 seconds
Time maintained above:		
-Temperature (T <sub>L</sub> )	183°C	217°C
- Time (t <sub>L</sub> )	60-150 seconds	60-150 seconds
Peak Temperature(T <sub>p</sub> )	240 +0/-5 °C	260 +0/-5 °C
Time within 5°C of actual peak temperature(tp)	10-30 seconds	20-40 seconds
Ramp down rate	6°C/second max.	6°C/second max.
Time 25 °C to peak temperature	6 minutes max.	8 minutes max.

Note : All temperatures refer to topside of the package, measured on the package body surface.



**TO-92 Dimension**

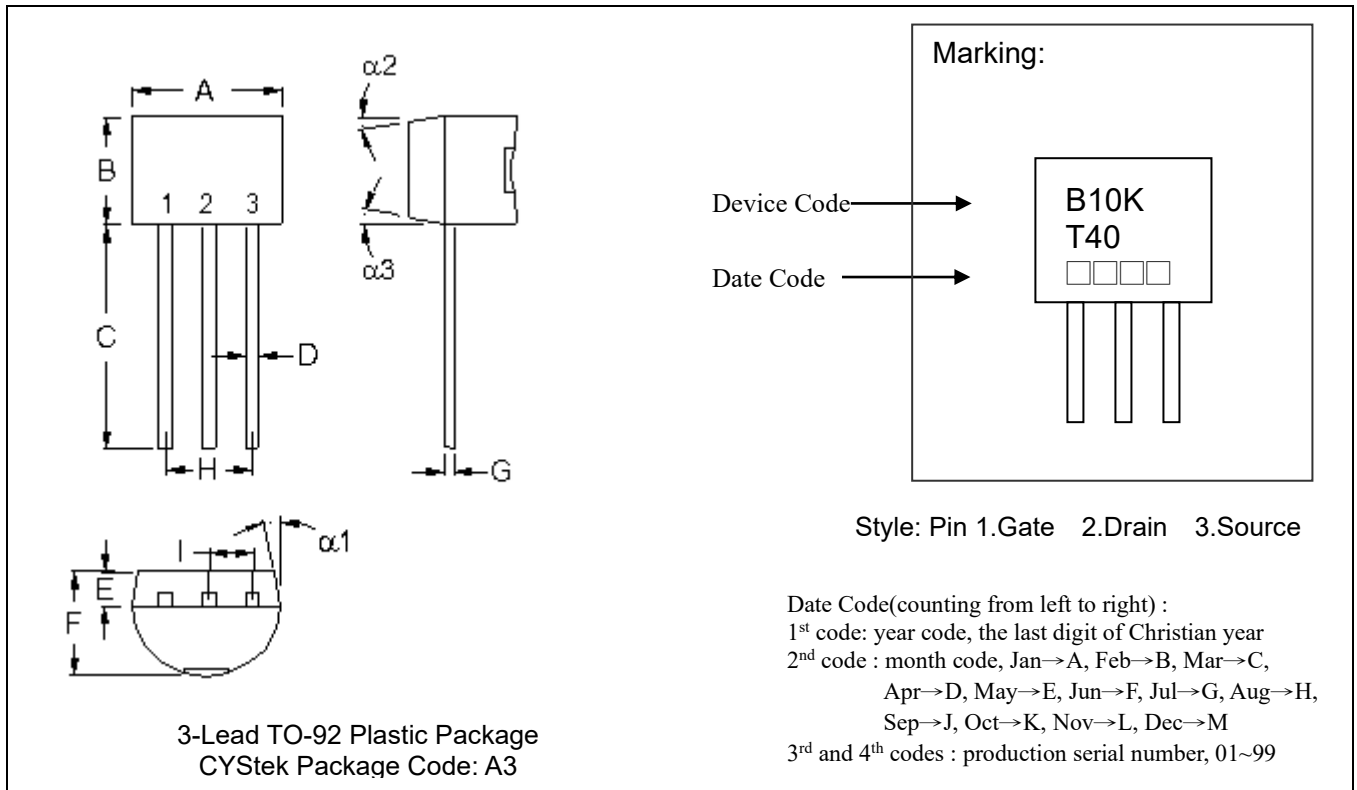

\*: Typical

DIM	Inches		Millimeters		DIM	Inches		Millimeters	
	Min.	Max.	Min.	Max.		Min.	Max.	Min.	Max.
A	0.1704	0.1902	4.33	4.83	G	0.0142	0.0220	0.36	0.56
B	0.1704	0.1902	4.33	4.83	H	-	*0.1000	-	*2.54
C	0.5000	-	12.70	-	I	-	*0.0500	-	*1.27
D	0.0142	0.0220	0.36	0.56	$\alpha 1$	-	*5°	-	*5°
E	-	*0.0500	-	*1.27	$\alpha 2$	-	*2°	-	*2°
F	0.1323	0.1480	3.36	3.76	$\alpha 3$	-	*2°	-	*2°

Notes: 1.Controlling dimension: millimeters.  
 2.Maximum lead thickness includes lead finish thickness, and minimum lead thickness is the minimum thickness of base material.  
 3.If there is any question with packing specification or packing method, please contact your local CYStek sales office.

**Material:**

- Lead: Pure tin plated.
- Mold Compound: Epoxy resin family, flammability solid burning class: UL94V-0.

**Important Notice:**

- All rights are reserved. Reproduction in whole or in part is prohibited without the prior written approval of CYStek.
- CYStek reserves the right to make changes to its products without notice.
- CYStek **semiconductor products are not warranted to be suitable for use in Life-Support Applications, or systems.**
- CYStek assumes no liability for any consequence of customer product design, infringement of patents, or application assistance.