

**N- Channel Enhancement Mode Power MOSFET**

# MTA080N02KSN3

**Features**

- Low Gate Charge
- RoHS compliant package
- ESD protected gate

$BV_{DSS}$	20V
$I_D @ V_{GS}=4.5V, T_A=25^\circ C$	2.6A
$R_{DS(ON) typ. @ V_{GS}=4.5V, I_D=1A}$	45mΩ
$R_{DS(ON) typ. @ V_{GS}=2.5V, I_D=1A}$	60mΩ
$R_{DS(ON) typ. @ V_{GS}=1.8V, I_D=0.5A}$	80mΩ

**Equivalent Circuit**

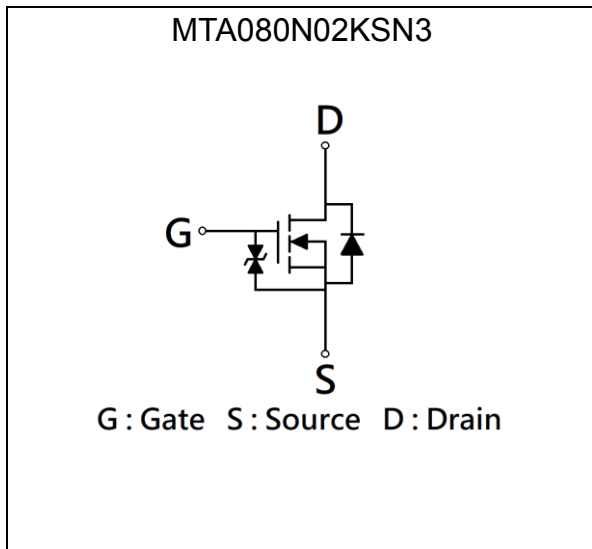

**Outline**

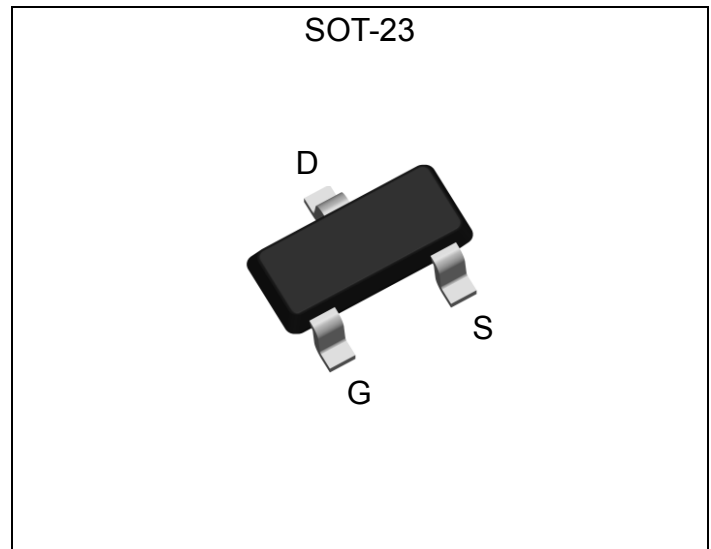

**Ordering Information**

Device	Package	Shipping
MTA080N02KSN3-0-T1-G	SOT-23 (Pb-free lead plating and halogen-free package)	3000 pcs / Tape & Reel

- ↑ Environment friendly grade : S for RoHS compliant products, G for RoHS compliant and green compound products
- ↑ Packing spec, T1 : 3000 pcs / tape & reel, 7" reel
- ↑ Product rank, zero for no rank products
- ↑ Product name

**Absolute Maximum Ratings (TA=25°C)**

Parameter	Symbol	Limits	Unit	
Drain-Source Voltage	V <sub>DS</sub>	20	V	
Gate-Source Voltage	V <sub>GS</sub>	±8		
Continuous Drain Current @ V <sub>GS</sub> =4.5V, T <sub>A</sub> =25°C	I <sub>D</sub>	2.6	A	
Continuous Drain Current @ V <sub>GS</sub> =4.5V, T <sub>A</sub> =70°C		2		
Pulsed Drain Current *a	I <sub>DM</sub>	10.4		
Continuous Body Diode Forward Current @ T <sub>A</sub> =25°C	I <sub>S</sub>	0.6		
ESD susceptibility *b	V <sub>ESD</sub>	1000	V	
Total Power Dissipation	P <sub>D</sub>	T <sub>A</sub> =25°C	0.7	W
		T <sub>A</sub> =70°C	0.5	
Operating Junction and Storage Temperature Range	T <sub>J</sub> , T <sub>stg</sub>	-55~+150	°C	

**Thermal Data**

Parameter	Symbol	Steady State	Unit
Thermal Resistance, Junction-to-ambient	R <sub>θJA</sub>	188	°C/W

Note:

\*a. Repetitive rating, pulse width limited by junction temperature T<sub>J</sub>(MAX)=150°C. Ratings are based on low frequency and low duty cycles to keep initial T<sub>J</sub>=25°C.

\*b. Human body model, 1.5kΩ in series with 100pF.



**Electrical Characteristics (T<sub>A</sub>=25°C, unless otherwise specified)**

Symbol	Min.	Typ.	Max.	Unit	Test Conditions
<b>Static</b>					
BV <sub>DSS</sub>	20	-	-	V	V <sub>GS</sub> =0V, I <sub>D</sub> =250μA
V <sub>GS(th)</sub>	0.3	-	1		V <sub>DS</sub> =V <sub>GS</sub> , I <sub>D</sub> =250μA
G <sub>FS</sub>	-	3	-	S	V <sub>DS</sub> =5V, I <sub>D</sub> =1A
I <sub>GSS</sub>	-	-	±10	μA	V <sub>GS</sub> =±8V, V <sub>DS</sub> =0V
I <sub>DSS</sub>	-	-	1		V <sub>DS</sub> =16V, V <sub>GS</sub> =0V
R <sub>DS(ON)</sub>	-	45	58	mΩ	V <sub>GS</sub> =4.5V, I <sub>D</sub> =1A
	-	60	90		V <sub>GS</sub> =2.5V, I <sub>D</sub> =1A
	-	80	160		V <sub>GS</sub> =1.8V, I <sub>D</sub> =0.5A
<b>Dynamic</b>					
C <sub>iss</sub>	-	137	-	pF	V <sub>DS</sub> =10V, V <sub>GS</sub> =0V, f=1MHz
C <sub>oss</sub>	-	32	-		
C <sub>rss</sub>	-	25	-		
R <sub>g</sub>	-	12	-	Ω	f=1MHz
Q <sub>g</sub> *1, 2	-	2.3	-	nC	V <sub>DS</sub> =16V, I <sub>D</sub> =1A, V <sub>GS</sub> =4.5V
Q <sub>gs</sub> *1, 2	-	0.7	-		
Q <sub>gd</sub> *1, 2	-	0.1	-		
t <sub>d(ON)</sub> *1, 2	-	3.7	-	ns	V <sub>DS</sub> =10V, I <sub>D</sub> =1A, V <sub>GS</sub> =4.5V, R <sub>GS</sub> =10Ω
t <sub>r</sub> *1, 2	-	17	-		
t <sub>d(OFF)</sub> *1, 2	-	18	-		
t <sub>f</sub> *1, 2	-	8.2	-		
<b>Source-Drain Diode</b>					
V <sub>SD</sub> *1	-	0.84	1.2	V	I <sub>S</sub> =1A, V <sub>GS</sub> =0V
t <sub>rr</sub>	-	4.2	-	ns	I <sub>F</sub> =1A, dI <sub>F</sub> /dt=100A/μs
Q <sub>rr</sub>	-	1.1	-	nC	

Note:

- \*1. Pulse Test : Pulse Width ≤300μs, Duty Cycle≤2%
- \*2. Independent of operating temperature

## Typical Characteristics

Typical Output Characteristics

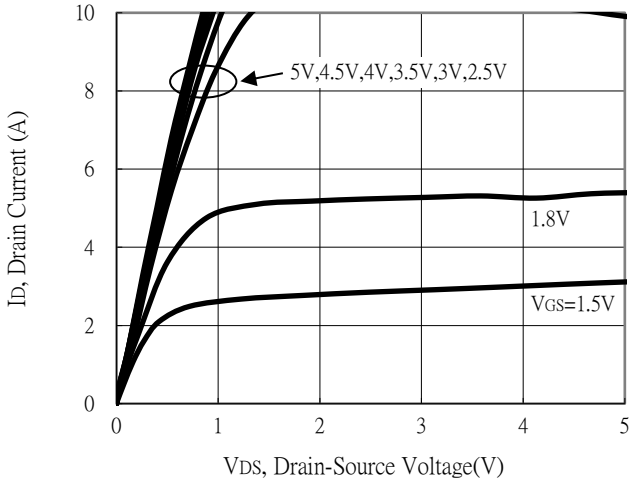

Breakdown Voltage vs Ambient Temperature

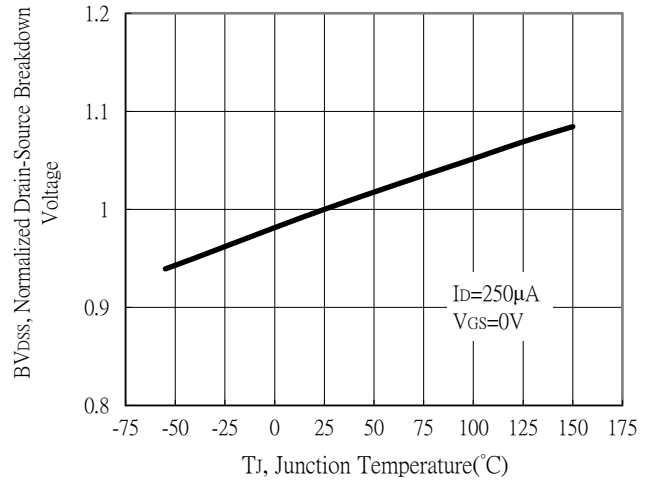

Static Drain-Source On-State resistance vs Drain Current

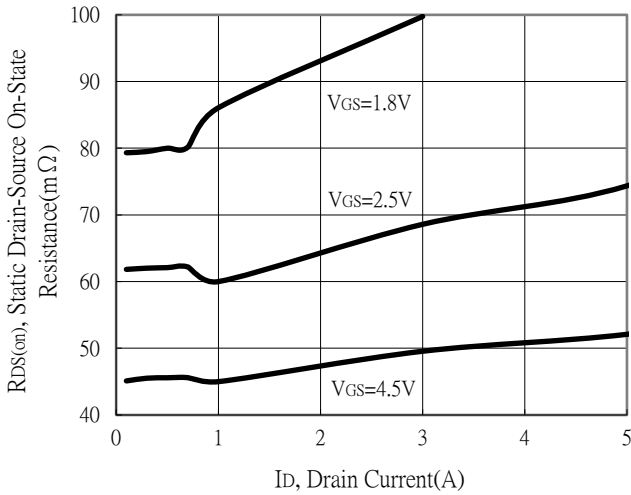

Body Diode Current vs Source-Drain Voltage

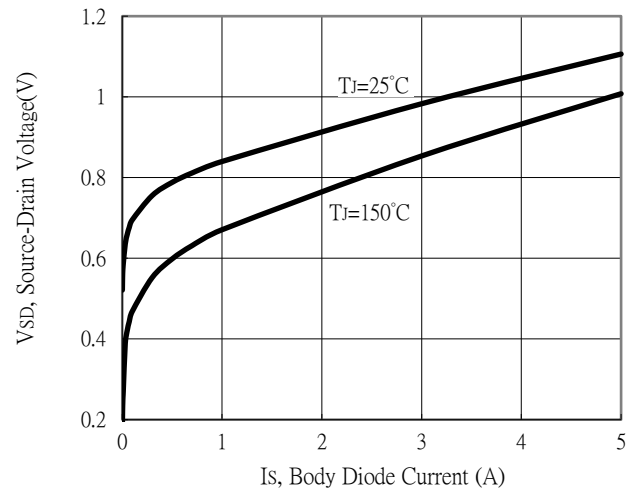

Static Drain-Source On-State Resistance vs Gate-Source Voltage

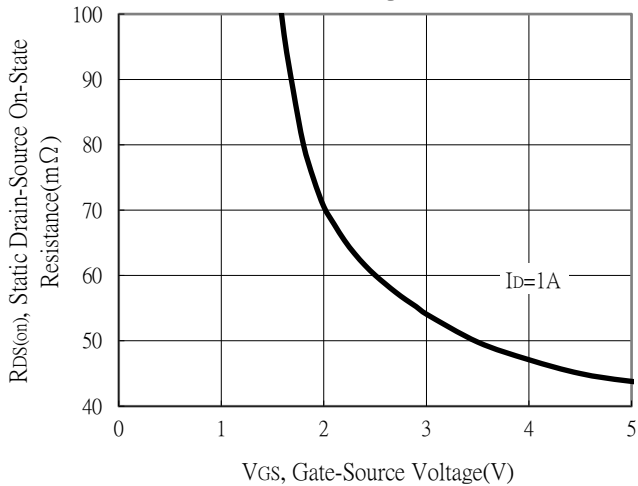

Drain-Source On-State Resistance vs Junction Temperature

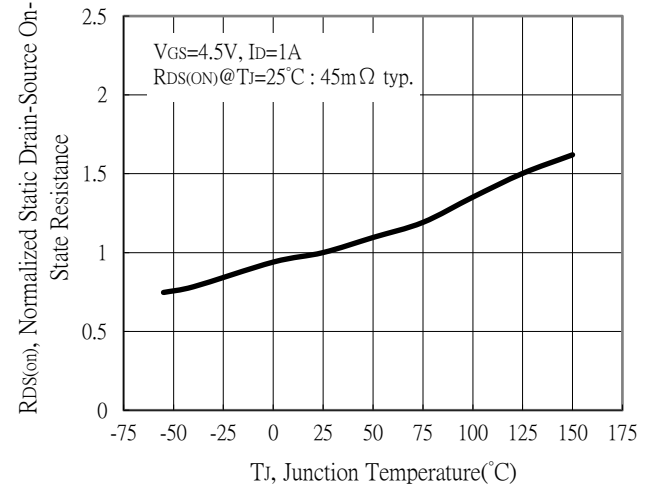



**Typical Characteristics (Cont.)**

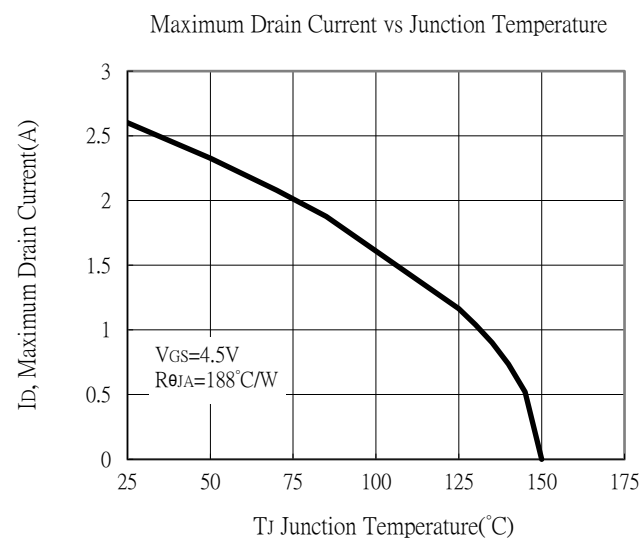
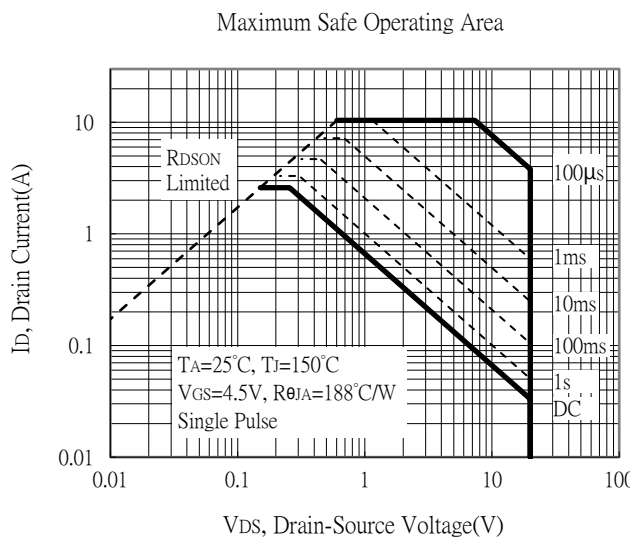
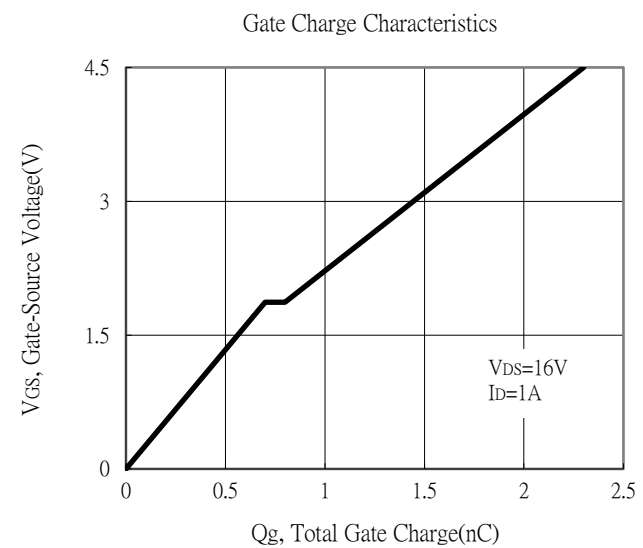
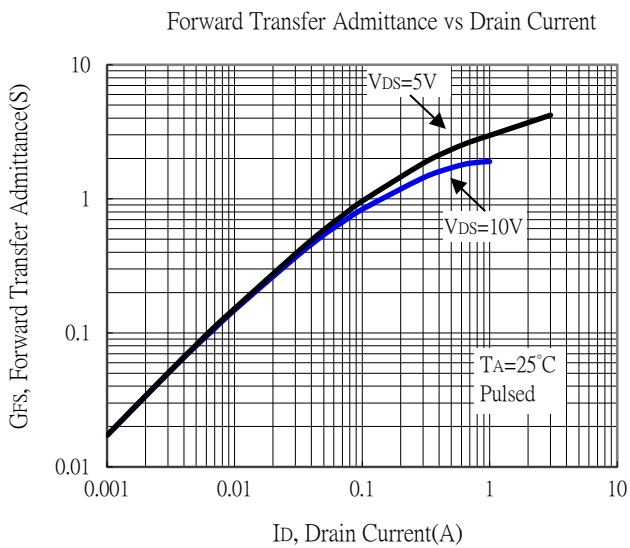
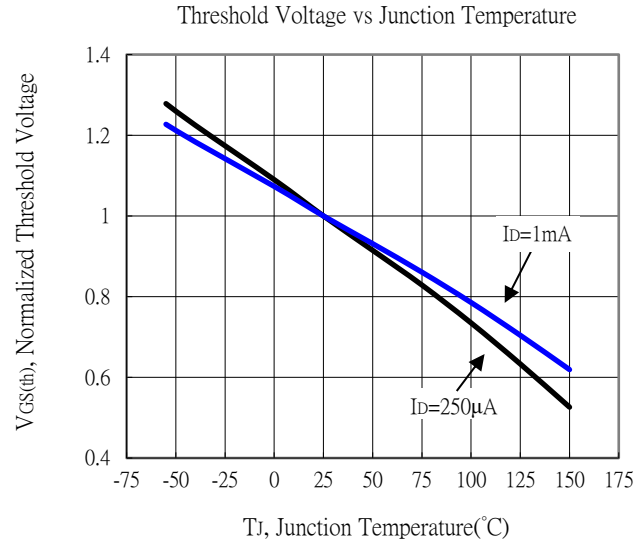
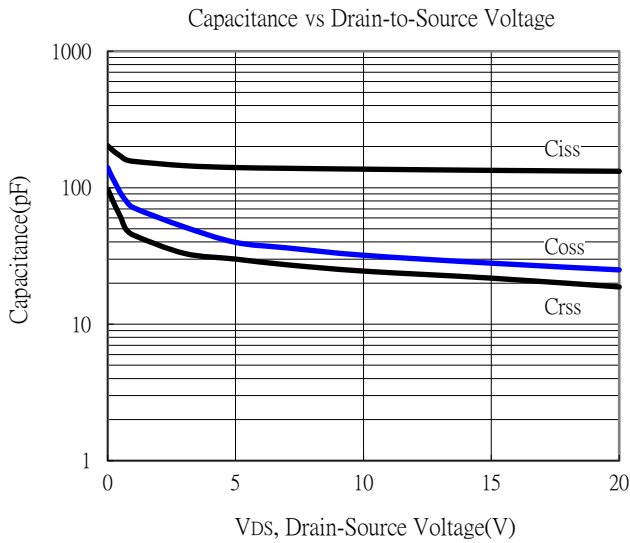

**Typical Characteristics (Cont.)**

Single Pulse Power Rating, Junction to Ambient

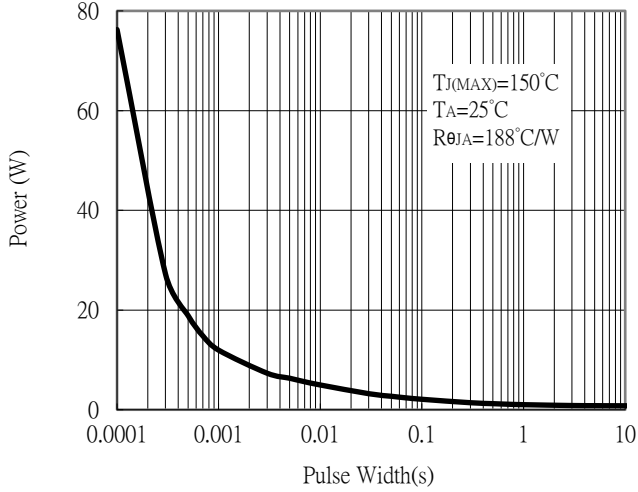

Transient Thermal Response Curves

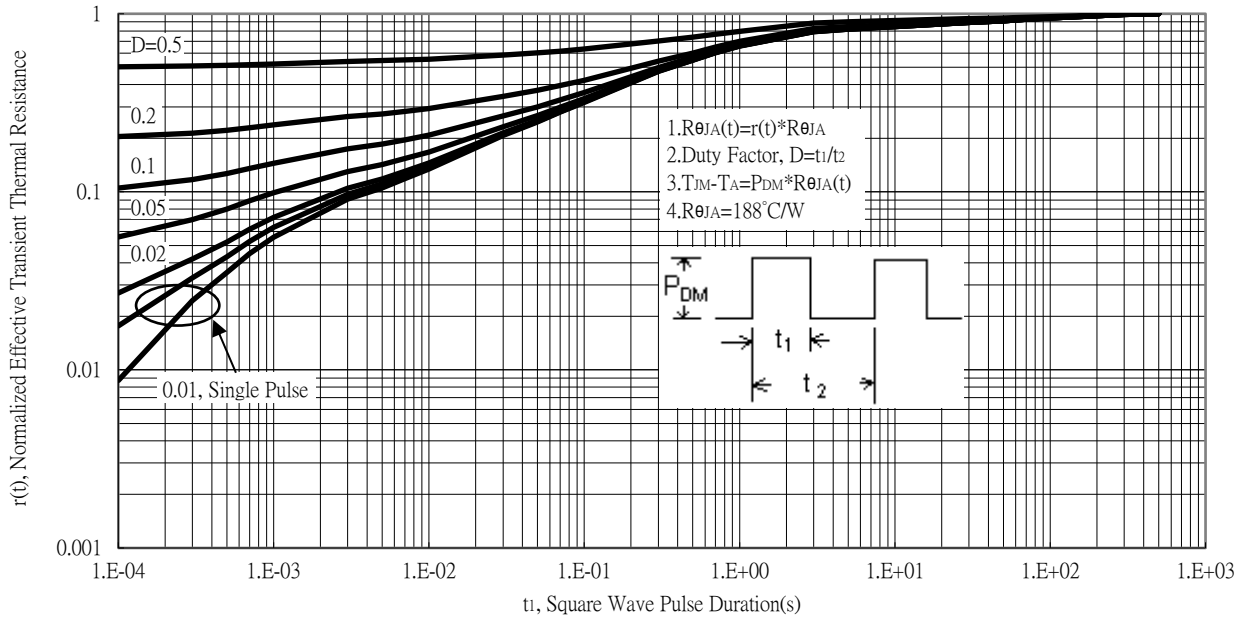

**Recommended Soldering Footprint**

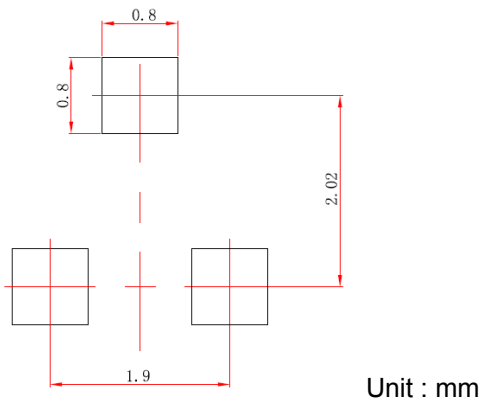

### Reel Dimension

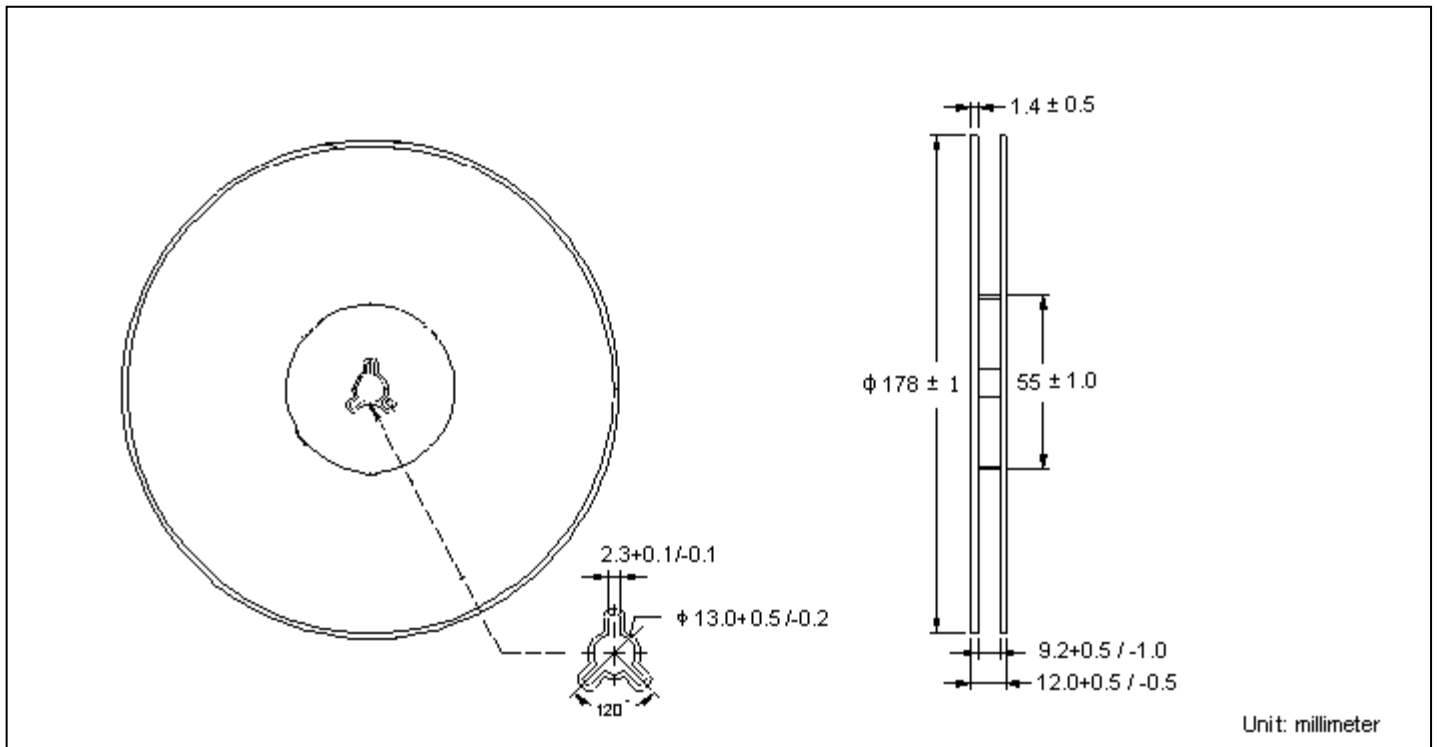

### Carrier Tape Dimension

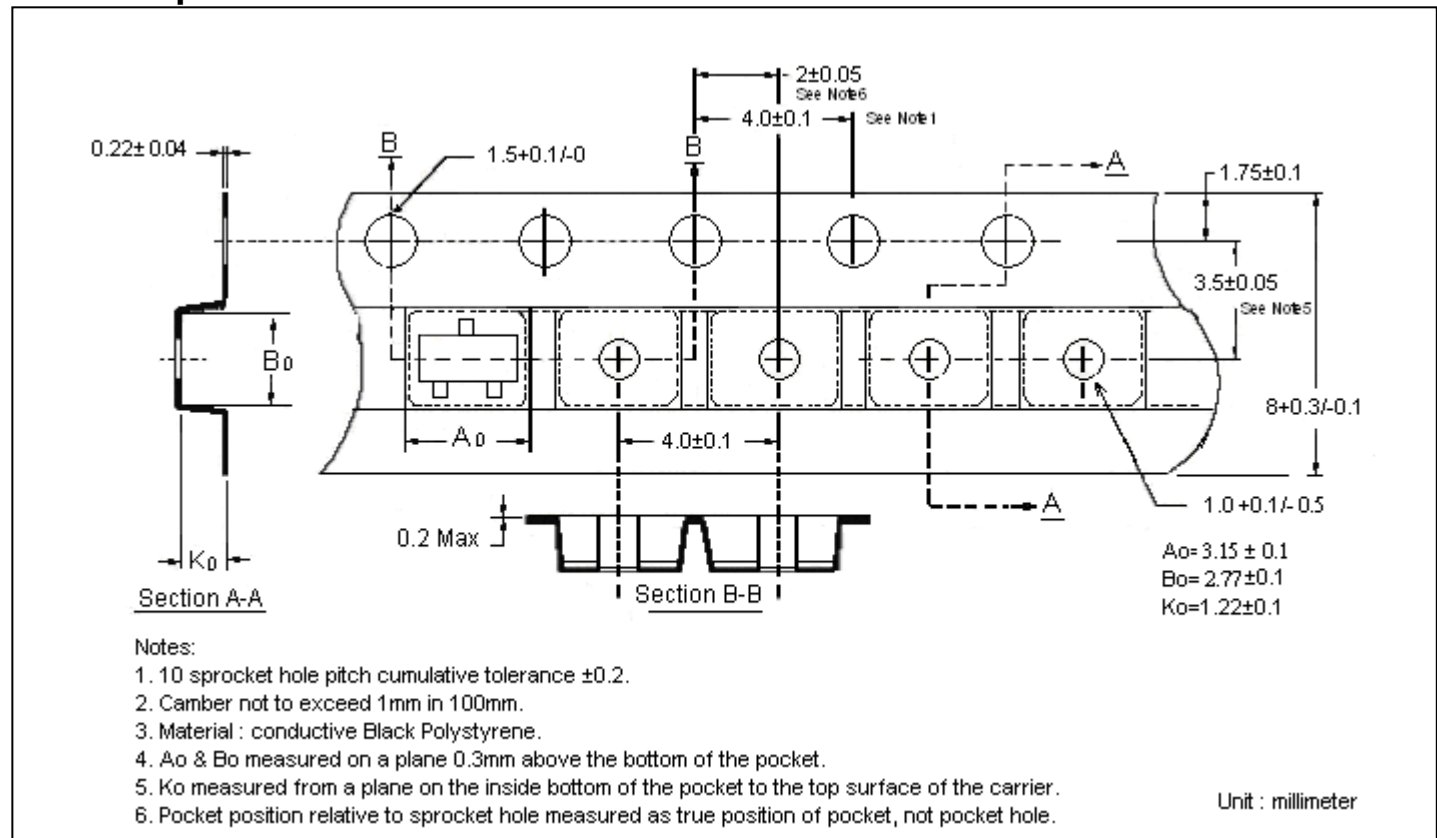

**Recommended wave soldering condition**

Product	Peak Temperature	Soldering Time
Pb-free devices	260 +0/-5 °C	5 +1/-1 seconds

**Recommended temperature profile for IR reflow**

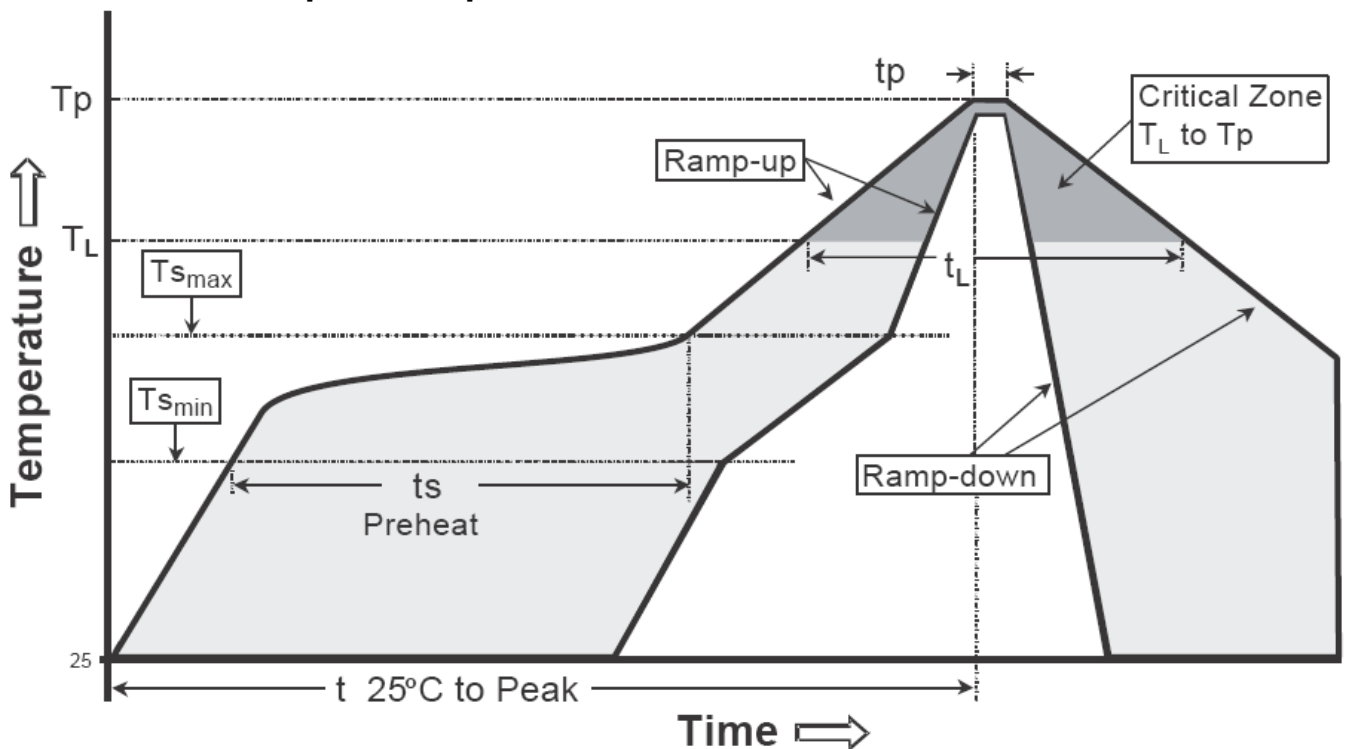

Profile feature	Sn-Pb eutectic Assembly	Pb-free Assembly
Average ramp-up rate (T <sub>smax</sub> to T <sub>p</sub> )	3°C/second max.	3°C/second max.
Preheat		
-Temperature Min(T <sub>s min</sub> )	100°C	150°C
-Temperature Max(T <sub>s max</sub> )	150°C	200°C
-Time(t <sub>s min</sub> to t <sub>s max</sub> )	60-120 seconds	60-180 seconds
Time maintained above:		
-Temperature (T <sub>L</sub> )	183°C	217°C
- Time (t <sub>L</sub> )	60-150 seconds	60-150 seconds
Peak Temperature(T <sub>P</sub> )	240 +0/-5 °C	260 +0/-5 °C
Time within 5°C of actual peak temperature(t <sub>p</sub> )	10-30 seconds	20-40 seconds
Ramp down rate	6°C/second max.	6°C/second max.
Time 25 °C to peak temperature	6 minutes max.	8 minutes max.

Note : All temperatures refer to topside of the package, measured on the package body surface.



**SOT-23 Dimension**

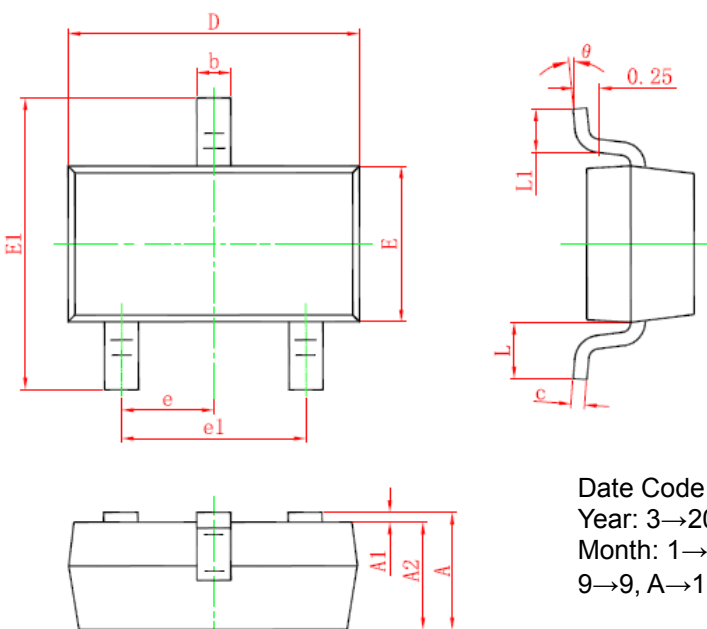

The diagram shows three views of the SOT-23 package: a top view with dimensions D, b, E1, E, e, and e1; a side view with dimensions L1, L, c, and lead angle  $\theta$  (0.25); and a bottom view with dimensions A1, A2, and A.

**Marking:**

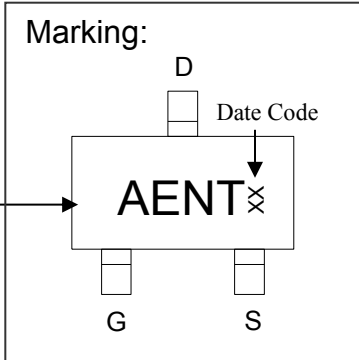

The marking diagram shows a rectangular package with a top lead (D), two bottom leads (G and S), and a central marking area. The marking area contains 'AENT' followed by a cross symbol. A 'Date Code' is indicated by an arrow pointing to the right of the cross. A 'Device Code' is indicated by an arrow pointing to the left of the cross.

Style: Pin 1.Gate 2.Source 3.Drain

Date Code: Year+Month  
 Year: 3→2003, 4→2004  
 Month: 1→1, 2→2, . . .  
 9→9, A→10, B→11, C→12

3-Lead SOT-23 Plastic  
 Surface Mounted Package  
 CYStek Package Code: N3

DIM	Inches		Millimeters		DIM	Inches		Millimeters	
	Min.	Max.	Min.	Max.		Min.	Max.	Min.	Max.
A	0.035	0.045	0.900	1.150	E1	0.089	0.100	2.250	2.550
A1	0.000	0.004	0.000	0.100	e	0.037 TYP.		0.950 TYP.	
A2	0.035	0.041	0.900	1.050	e1	0.071	0.079	1.800	2.000
b	0.012	0.020	0.300	0.500	L	0.022 REF.		0.550 REF.	
c	0.003	0.006	0.080	0.150	L1	0.012	0.020	0.300	0.500
D	0.110	0.118	2.800	3.000	$\theta$	0°	8°	0°	8°
E	0.047	0.055	1.200	1.400					

**Notes:** 1.Controlling dimension: millimeters.  
 2.Maximum lead thickness includes lead finish thickness, and minimum lead thickness is the minimum thickness of base material.  
 3.If there is any question with packing specification or packing method, please contact your local CYStek sales office.

**Material:**

- Lead: Pure tin plated.
- Mold Compound: Epoxy resin family, flammability solid burning class: UL94V-0.

**Important Notice:**

- All rights are reserved. Reproduction in whole or in part is prohibited without the prior written approval of CYStek.
- CYStek reserves the right to make changes to its products without notice.
- CYStek **semiconductor products are not warranted to be suitable for use in Life-Support Applications, or systems.**
- CYStek assumes no liability for any consequence of customer product design, infringement of patents, or application assistance.