



**Simple Switcher
3A Step- Down Voltage Regulator**

LM2576-XXE5/F5

Features

- 3.3V, 5V, 12V, 15V, and adjustable output versions.
- Adjustable version output voltage range, 1.23V to 37V \pm 4% max over line and load conditions.
- Guaranteed 3A output current.
- Wide input voltage range.
- Requires only 4 external components
- 52 kHz fixed frequency oscillator
- TTL shutdown capability, low power standby mode.
- High efficiency
- Uses readily available standard inductors.
- Thermal shutdown and current limit protection.

Description

The LM2576-XXE5/F5 series of regulators are monolithic integrated circuits that provide all the active functions for a step-down (buck) switching regulator, capable of driving 3A load with excellent line and load regulation. These devices are available in fixed output voltages of 3.3V, 5V, 12V, 15V, and an adjustable output version. Requiring a minimum number of external components, these regulators are simple to use and include internal frequency compensation and a fixed-frequency oscillator.

The LM2576-XXE5/F5 series offers a high-efficiency replacement for popular three-terminal linear regulators. It substantially reduces the size of the heat sink, and in some cases no heat sink is required.

A standard series of inductors optimized for use with the LM2576 are available from several different manufacturers. This feature greatly simplifies the design of switch-mode power supplies.

Other features include a guaranteed \pm 4% tolerance on output voltage within specified input voltages and output load conditions, and \pm 10% on the oscillator frequency. External shutdown is included, featuring 50 μ A (typical) standby current. The output switch includes cycle-by-cycle current limiting, as well as thermal shutdown for full protection under fault conditions.

Applications

- Simple high-efficiency step-down (buck) regulator.
- Efficient pre-regulator for linear regulators.
- On-card switching regulators.
- Positive to negative converter (Buck-Boost).

Typical Application (Fixed Output Voltage Version)

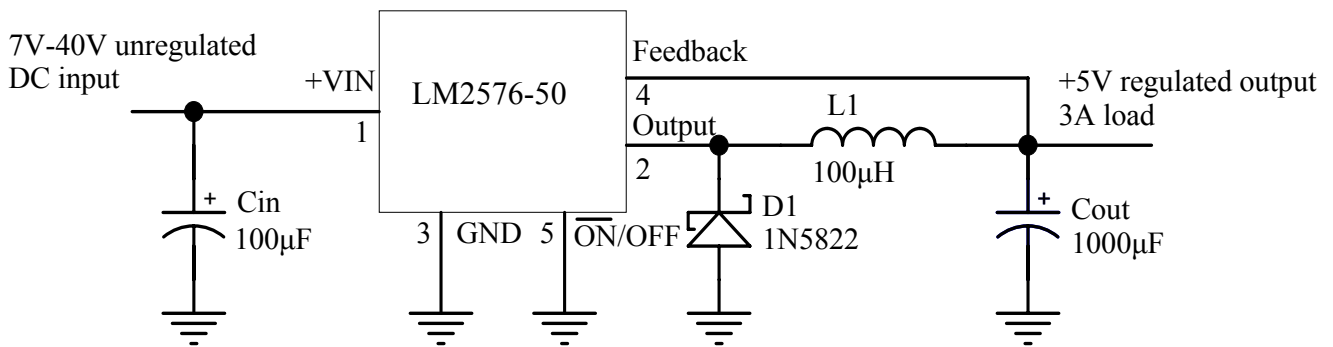
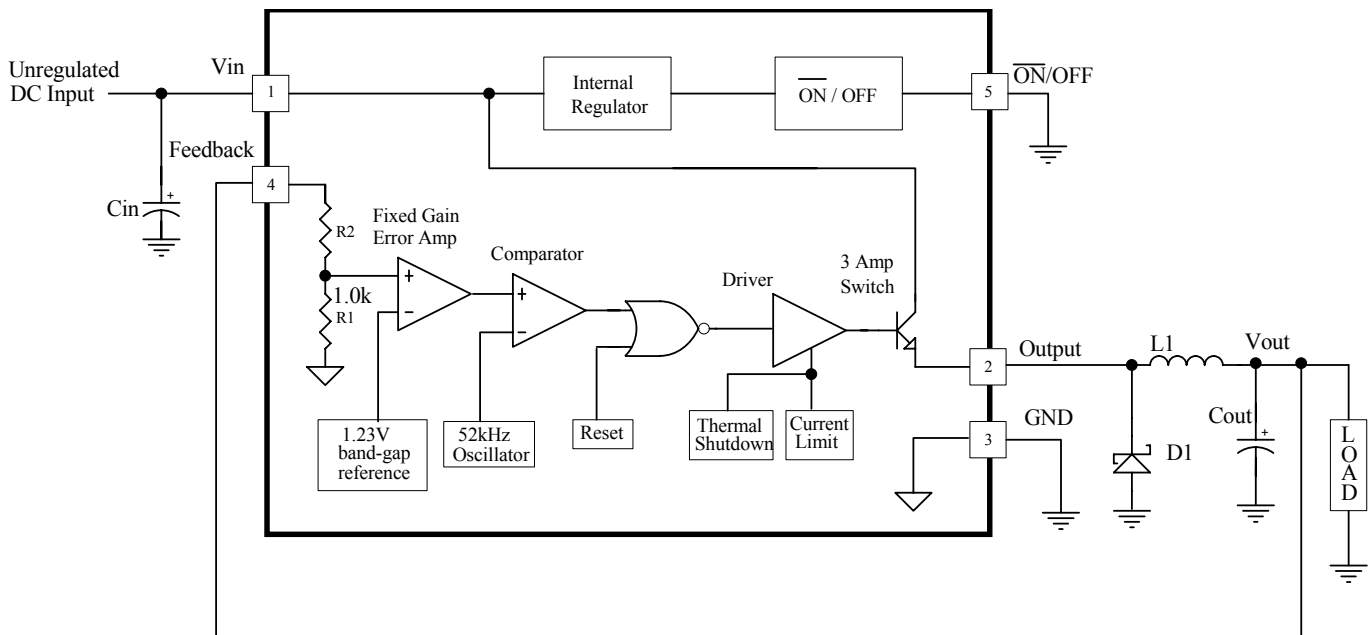

Figure. 1

Block Diagram



3.3V, R2=1.7k
 5V, R2=3.1k
 12V, R2=8.84k
 15V, R2=11.3k
 For Adjustable version, R1=open, R2=0

Ordering Information

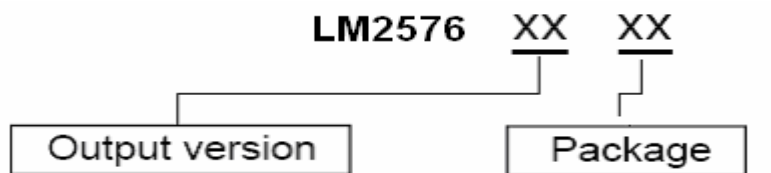

Blank : Adjustable

-33 : 3.3V

-50 : 5.0V

-12 : 12V

-15 : 15V

E5 : TO-220-5L

F5 : TO-263-5L



Absolute Maximum Ratings (Note 1)

Parameter	Symbol	Value	Unit
Supply Voltage	V _{CC}	45	V
On/Off Pin Input Voltage	V _{SD}	-0.3 ~ +V _{IN}	V
Output Voltage to Ground	V _{OUT}	-1	V
Power Dissipation	P _D	Internally Limited	W
Operating Temperature	T _{opr}	-40 ~ +125	°C
Storage Temperature	T _{stg}	-65 ~ +150	°C
ESD Susceptibility (Note 2)		2000	V
Lead Temperature (soldering, 10 seconds)	T _L	260	°C

LM2576-33 Electrical Characteristics

Specifications with standard type face are for T_J=25°C, and those with **boldface type** apply over full operating temperature range

Symbol	Parameter	Conditions	Typ	Min	Max	Units
System Parameters (Note 3) Test Circuit Figure 2						
V _{OUT}	Output Voltage	V _{IN} =12V, I _{LOAD} =0.5A Circuit of Figure 2	3.3	3.234	3.336	V
V _{OUT}	Output Voltage	6V ≤ V _{IN} ≤ 40V, 0.5A ≤ I _{LOAD} ≤ 3A Circuit of Figure 2	3.3	3.168/ 3.135	3.432/ 3.465	V
η	Efficiency	V _{IN} =12V, I _{LOAD} =3A	75			%

LM2576-50 Electrical Characteristics

Specifications with standard type face are for T_J=25°C, and those with **boldface type** apply over full operating temperature range

Symbol	Parameter	Conditions	Typ	Min	Max	Units
System Parameters (Note 3) Test Circuit Figure 2						
V _{OUT}	Output Voltage	V _{IN} =12V, I _{LOAD} =0.5A Circuit of Figure 2	5.0	4.9	5.1	V
V _{OUT}	Output Voltage	8V ≤ V _{IN} ≤ 40V, 0.5A ≤ I _{LOAD} ≤ 3A Circuit of Figure 2	5.0	4.800/ 4.750	5.200/ 5.250	V
η	Efficiency	V _{IN} =12V, I _{LOAD} =3A	77			%



LM2576-12 Electrical Characteristics

Specifications with standard type face are for $T_J=25^{\circ}\text{C}$, and those with **boldface type** apply over full operating temperature range

Symbol	Parameter	Conditions	Typ	Min	Max	Units
System Parameters (Note 3) Test Circuit Figure 2						
V_{OUT}	Output Voltage	$V_{IN}=25\text{V}$, $I_{LOAD}=0.5\text{A}$ Circuit of Figure 2	12	11.76	12.24	V
V_{OUT}	Output Voltage	$15\text{V} \leq V_{IN} \leq 40\text{V}$, $0.5\text{A} \leq I_{LOAD} \leq 3\text{A}$ Circuit of Figure 2	12	11.52/ 11.40	12.48/ 12.60	V
η	Efficiency	$V_{IN}=15\text{V}$, $I_{LOAD}=3\text{A}$	88			%

LM2576-15 Electrical Characteristics

Specifications with standard type face are for $T_J=25^{\circ}\text{C}$, and those with **boldface type** apply over full operating temperature range

Symbol	Parameter	Conditions	Typ	Min	Max	Units
System Parameters (Note 3) Test Circuit Figure 2						
V_{OUT}	Output Voltage	$V_{IN}=25\text{V}$, $I_{LOAD}=0.5\text{A}$ Circuit of Figure 2	15	14.7	15.3	V
V_{OUT}	Output Voltage	$18\text{V} \leq V_{IN} \leq 40\text{V}$, $0.5\text{A} \leq I_{LOAD} \leq 3\text{A}$ Circuit of Figure 2	15	14.40/ 14.25	15.60/ 15.75	V
η	Efficiency	$V_{IN}=18\text{V}$, $I_{LOAD}=3\text{A}$	88			%

LM2576-ADJ Electrical Characteristics

Specifications with standard type face are for $T_J=25^{\circ}\text{C}$, and those with **boldface type** apply over full operating temperature range

Symbol	Parameter	Conditions	Typ	Min	Max	Units
System Parameters (Note 3) Test Circuit Figure 2						
V_{OUT}	Feedback Voltage	$V_{IN}=12\text{V}$, $I_{LOAD}=0.5\text{A}$, $V_{OUT}=5\text{V}$, Circuit of Figure 2	1.230	1.217	1.243	V
V_{OUT}	Feedback Voltage	$8\text{V} \leq V_{IN} \leq 40\text{V}$, $0.5\text{A} \leq I_{LOAD} \leq 3\text{A}$ $V_{OUT}=5\text{V}$, Circuit of Figure 2	1.230	1.193/ 1.180	1.267/ 1.280	V
η	Efficiency	$V_{IN}=12\text{V}$, $I_{LOAD}=3\text{A}$, $V_{OUT}=5\text{V}$	77			%



All Output Voltage Versions Electrical Characteristics

Specifications with standard type face are for $T_J=25^{\circ}C$, and those with **boldface type** apply over full operating temperature range. Unless otherwise specified, $V_{IN}=12V$ for the 3.3V, 5.0V, and adjustable versions, $V_{IN}=25V$ for the 12V version, and $V_{IN}=30V$ for the 15V version. $I_{LOAD}=500mA$.

Symbol	Parameter	Conditions	Typ	Min	Max	Units
I _b	Feedback bias current	V _{OUT} =5V (adjustable version only)	50	-	100/ 500	nA
f _o	Oscillator frequency	(Note 8)	52	47/ 42	58/ 63	kHz
V _{SAT}	Saturation voltage	I _{OUT} =3A (Note 4)	1.4	-	1.8/ 2.0	V
DC	Maximum duty cycle (ON)	(Note 5)	98	93	-	%
I _{CL}	Current limit	(Notes 4, 8)	5.8	4.2/ 3.5	6.9/ 7.5	A
I _L	Output leakage current	(Notes 6, 7) Output = 0V Output = -1V	- 7.5	- -	2 30	mA
I _Q	Quiescent current	(Note 6)	5	-	10	mA
I _{STBY}	Standby quiescent current	— ON/OFF pin=5V (OFF)	50	-	200	μA

ON/OFF Control

V _{IH}	—	V _{OUT} =0V	1.4	2.2/ 2.4	-	V
V _{IL}	ON/OFF pin logic input level	V _{OUT} =Nominal output voltage	1.2	-	1.0/ 0.8	V
I _{IH}	—	—	12	-	30	μA
I _{IL}	ON/OFF pin input current	ON/OFF pin=5V (OFF)	—	—	—	—
		ON/OFF pin=0V (ON)	0	-	10	μA

Note 1 : Absolute Maximum Ratings indicate limits beyond which damage to the device may occur. Operating Ratings indicate conditions for which the device is intended to be functional, but do not guarantee specific performance limits. For guaranteed specifications and test conditions, see the Electrical Characteristics.

Note 2 : All limits guaranteed at room temperature (standard type face) and at temperature extremes (bold type face).

Note 3 : External components such as the catch diode, inductor, input and output capacitors can affect switching regulator system performance. When the LM2576 is used as shown in the figure 2 test circuit, system performance will be as shown in system parameters section of Electrical Characteristics.

Note 4 : Output pin sourcing current. No diode, inductor or capacitor connected to output.

Note 5 : Feedback pin removed from output and connected to 0V.

Note 6 : Feedback pin removed from output and connected to +12V for the Adjustable, 3.3V, and 5V versions, and +25V for the 12V and 15V versions, to force the output transistor OFF.

Note 7 : V_{IN}=40V.

Note 8 : The oscillator frequency reduces to approximately 11 kHz in the event of an output short or an overload which causes the regulated output voltage to drop approximately 40% from the nominal output voltage. This self protection feature lowers the average power dissipation of the IC by lowering the minimum duty cycle from 5% down to approximately 2%.

Typical Performance Characteristics (circuit of Figure 2)

Normalized Output Voltage

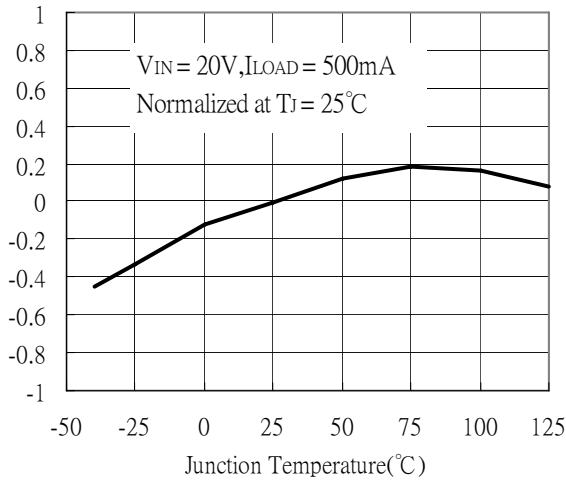

Line Regulation

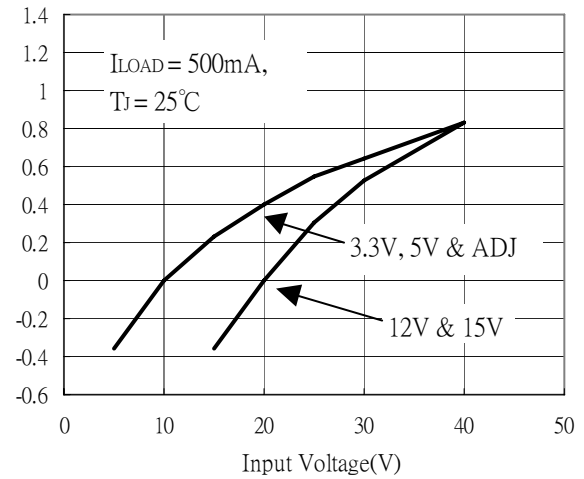

Dropout Voltage

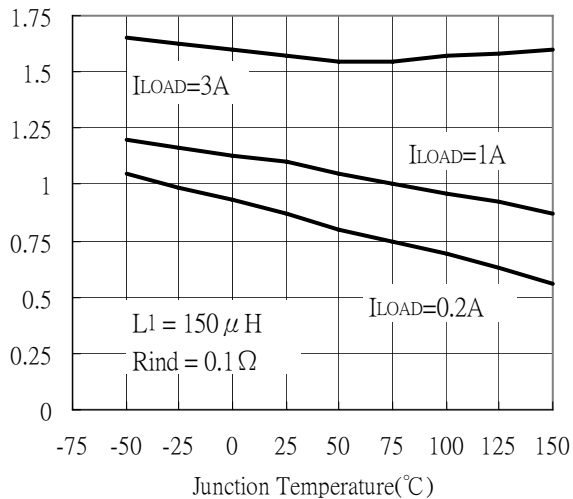

Standby Quiescent Current

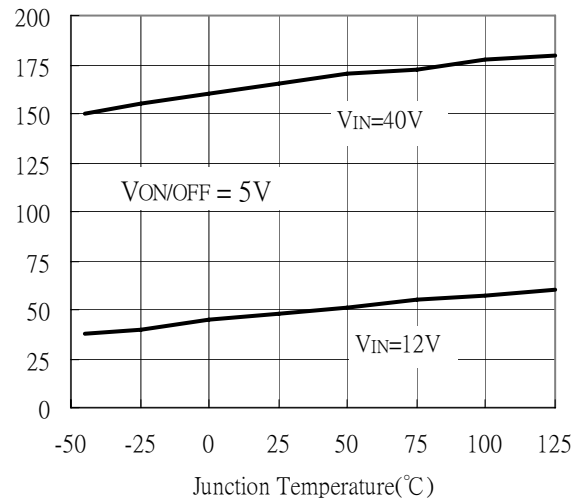

Quiescent Current

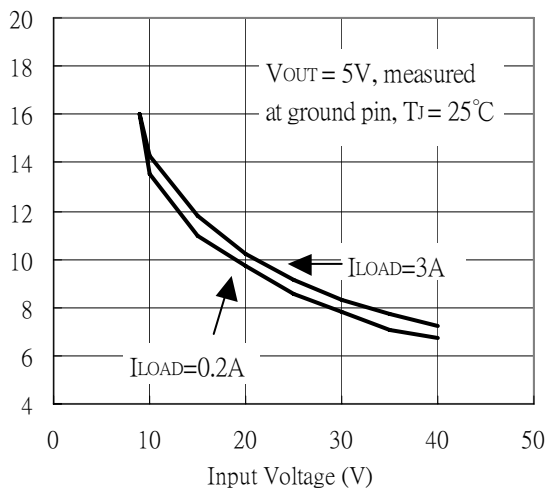

Current Limit

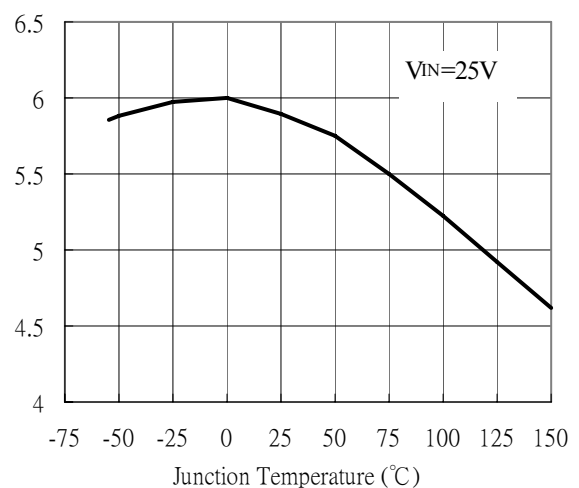



Switch Saturation Voltage

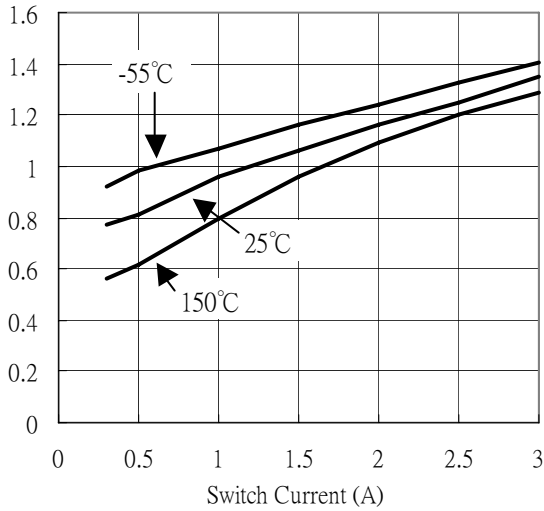

Efficiency

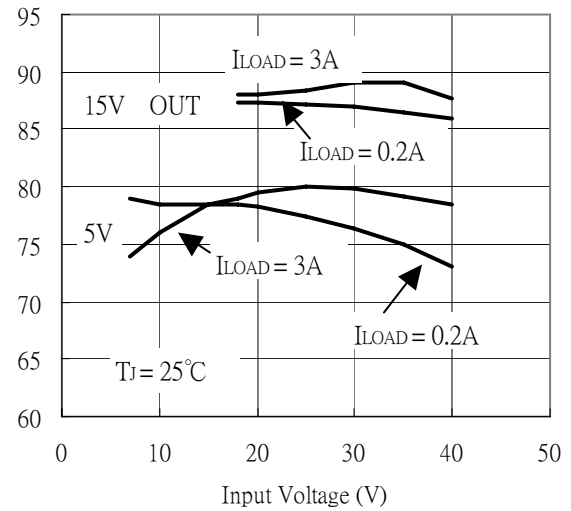

Oscillator Frequency

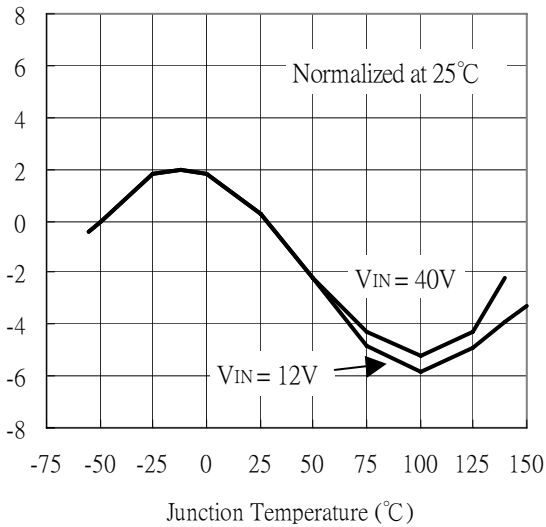

Minimum Operating Voltage

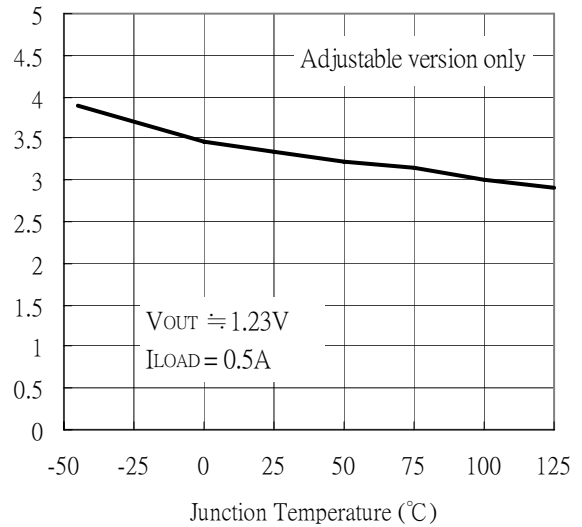

Quiescent Current vs Duty Cycle

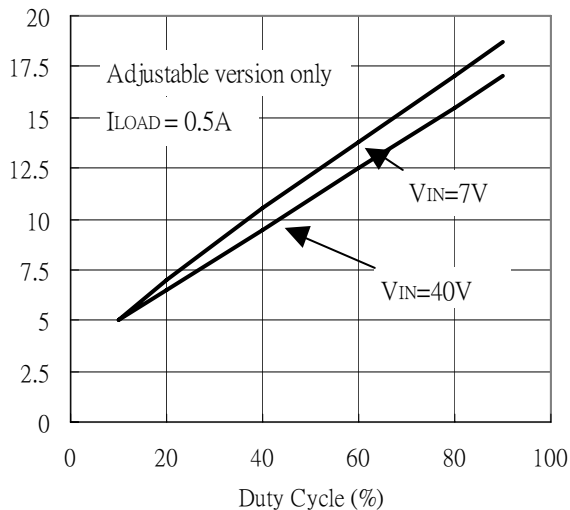

Feedback Voltage vs Duty Cycle

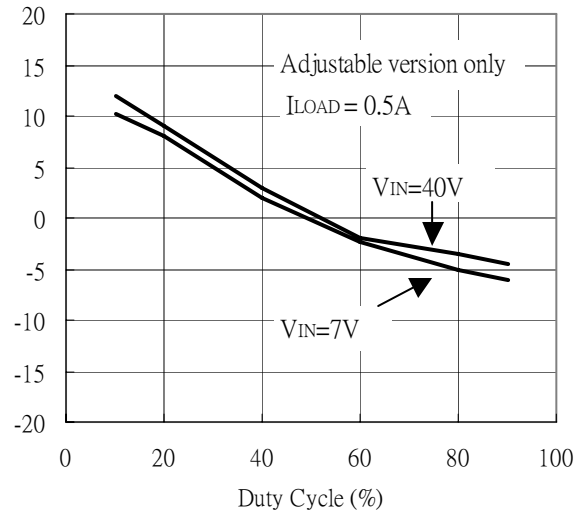

Minimum Power Dissipation

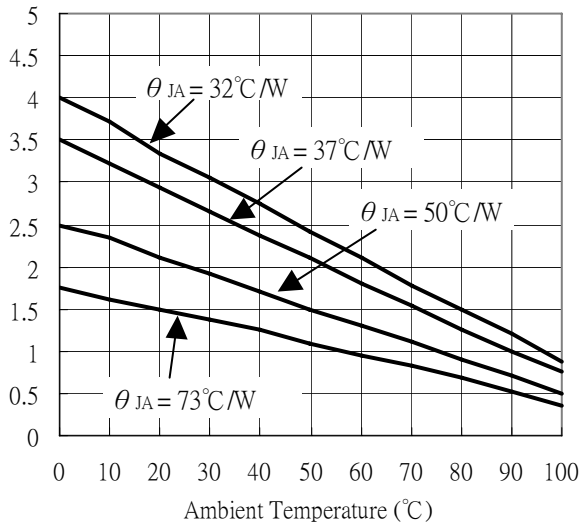

Feedback Pin Current

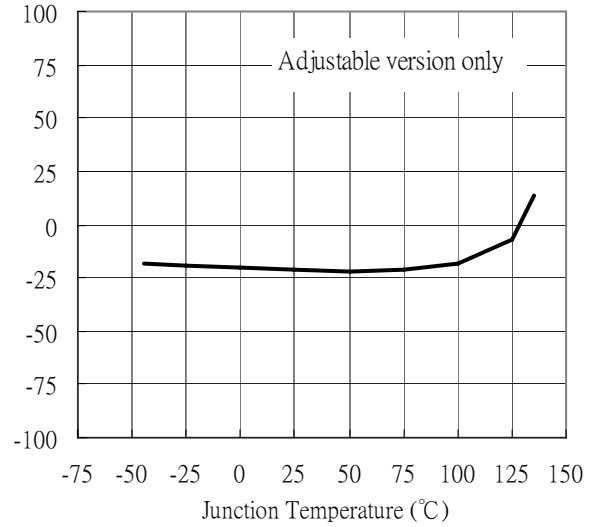

Switching Waveforms

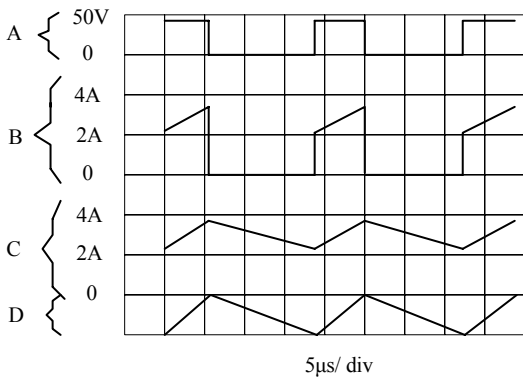

Load Transient Response

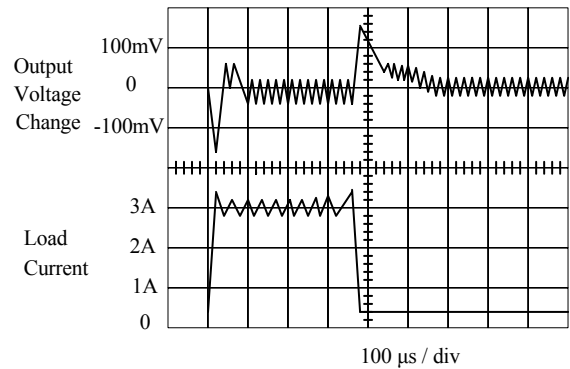

VOUT=15V

A : Output Pin Voltage, 50 V / div

B : Output Pin Current, 2A / div

C : Inductor Current, 2A / div

D : Output Ripple Voltage, 50mV / div

AC Coupled

Horizontal Time Base : 5µs / div

Test Circuit and Layout Guidelines

As in any switching regulator, layout is very important. Rapidly switching currents associated with wiring inductance generate voltage transients which can cause problems. For minimal inductance and ground loops, the length of the leads indicated by heavy lines should be kept as short as possible. Single-point grounding (as indicated) or ground plane construction should be used for best results. When using the Adjustable version, physically locate the programming resistors near the regulator, to keep the sensitive feedback wiring short.

Fixed Output Voltage Versions

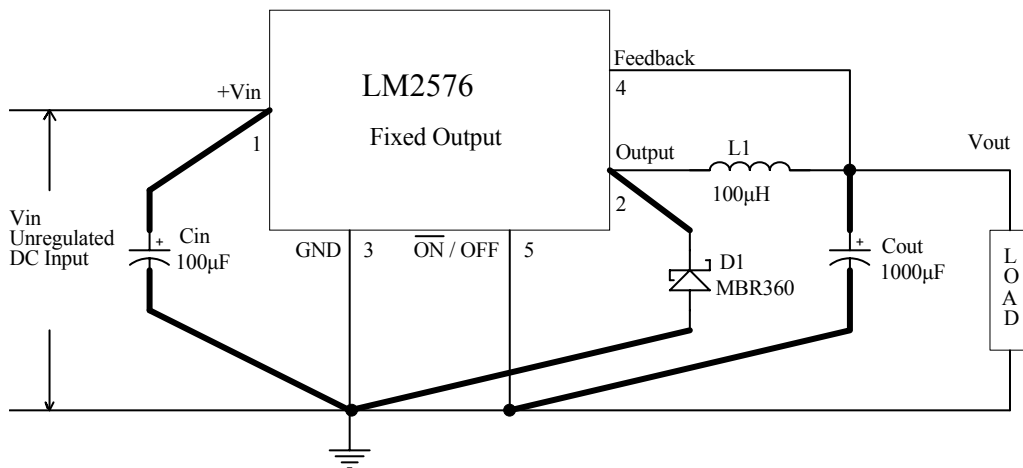

Cin--100µF, 75V, Aluminum Electrolytic
 Cout--1000µF, 25V, Aluminum Electrolytic
 D1--Schottky, MBR360
 L1--100µH, Pulse Eng, PE92108
 R1--2k, 0.1%
 R2--6.12k, 0.1%

Adjustable Output Voltage Version

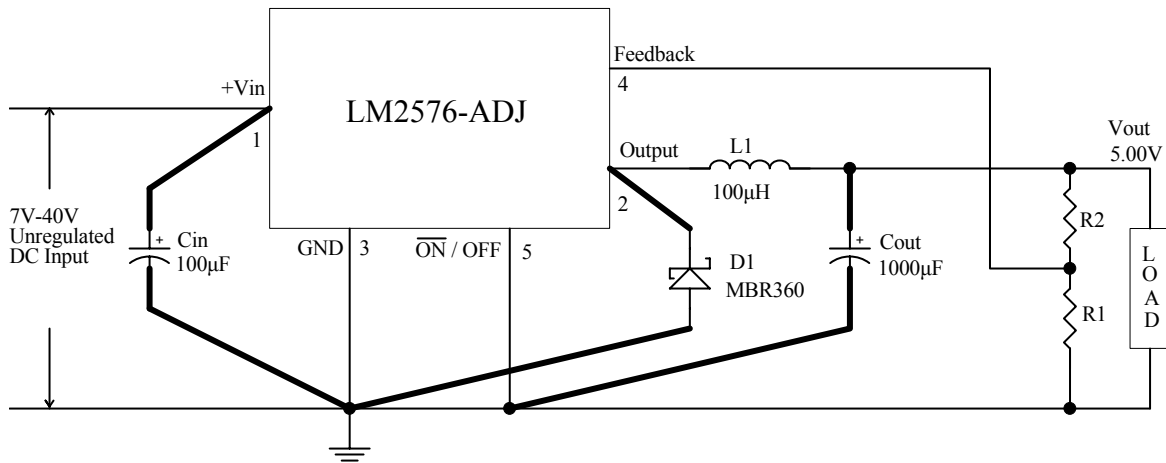

$$V_{out} = V_{REF} \left(1 + \frac{R_2}{R_1} \right)$$

$$R_2 = R_1 \left(\frac{V_{out}}{V_{REF}} - 1 \right)$$

where $V_{REF} = 1.23V$, R_1 between 1k and 5k

Figure 2

TO-263-5L Dimension

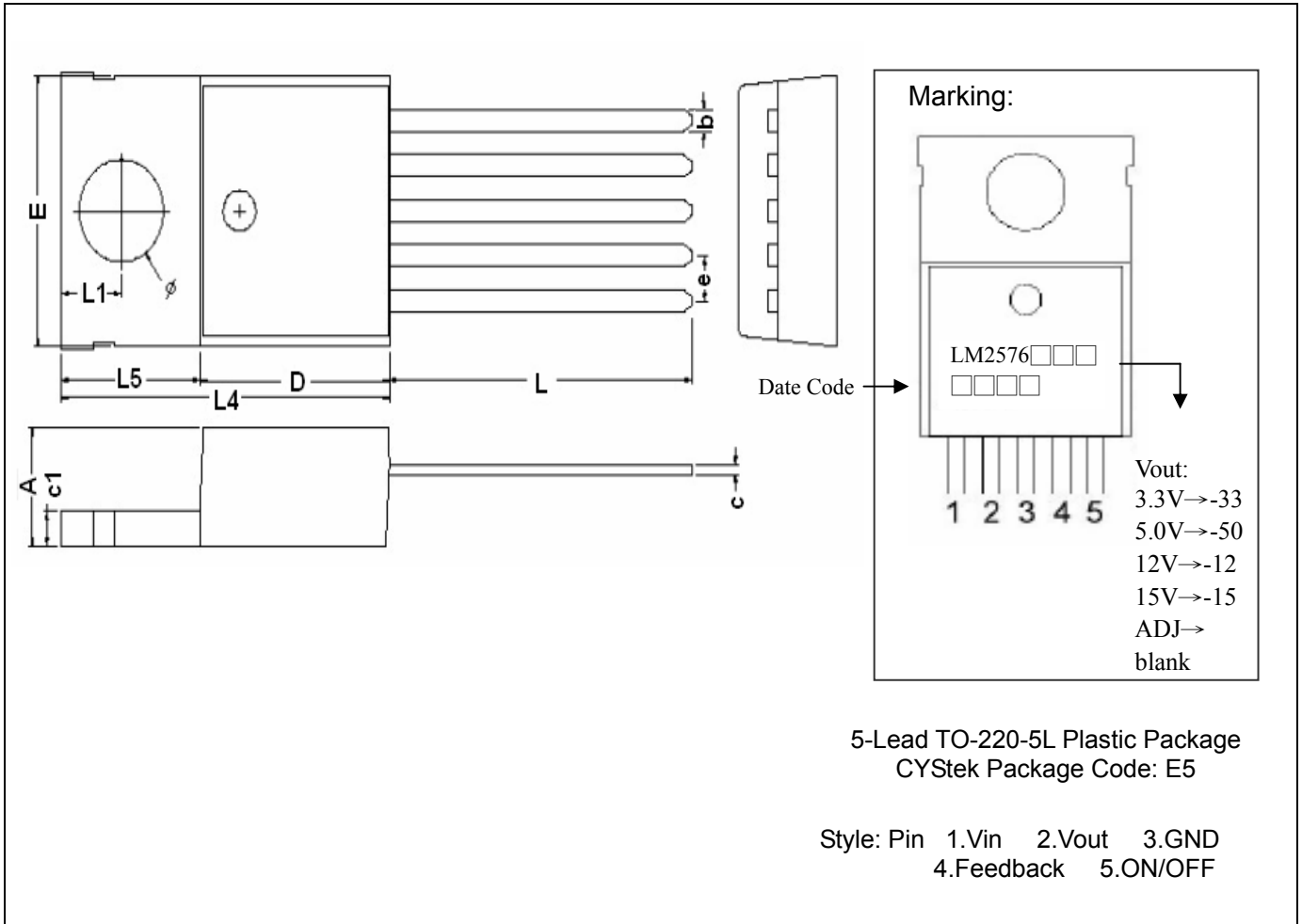

DIM	Inches		Millimeters		DIM	Inches		Millimeters	
	Min.	Max.	Min.	Max.		Min.	Max.	Min.	Max.
A	0.173	0.189	4.40	4.80	L5	0.244	0.260	6.20	6.60
b	0.030	0.039	0.76	1.00	c1	0.049	0.057	1.25	1.45
c	0.014	0.020	0.36	0.50	L	0.522	0.561	13.25	14.25
D	0.339	0.354	8.60	9.00	e	0.067 REF		1.70 REF	
E	0.386	0.409	9.80	10.4	L1	0.102	0.114	2.60	2.89
L4	0.579	0.602	14.7	15.3	φ	0.146	0.156	3.71	3.96

Notes: 1.Controlling dimension: millimeter
 2.Maximum lead thickness includes lead finish thickness, and minimum lead thickness is the minimum thickness of base material.
 3.If there is any question with packing specification or packing method, please contact your local CYStek sales office.

Material:
 • Mold Compound: Epoxy resin family, flammability solid burning class: UL94V-0

TO-263-5L Dimension

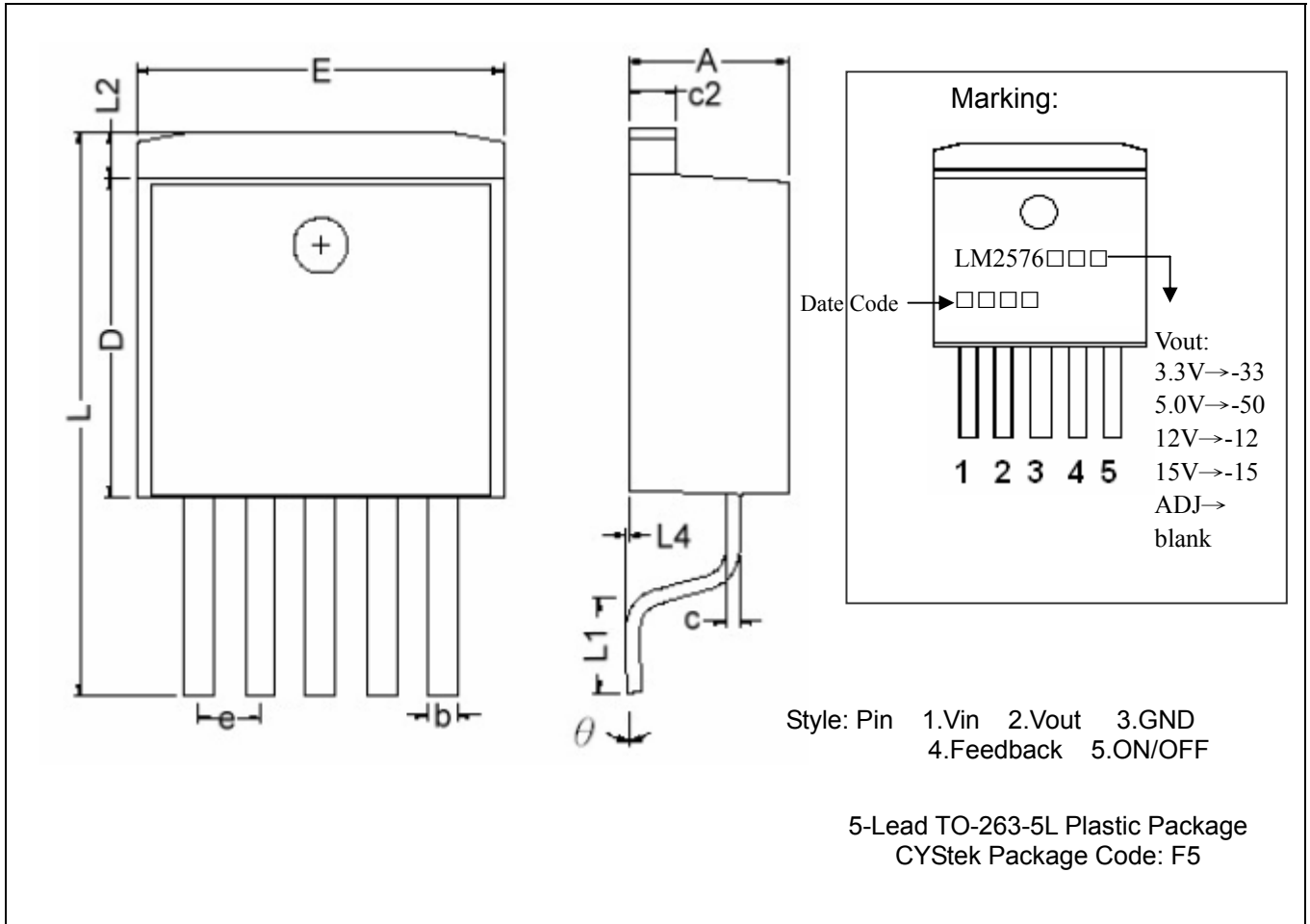

DIM	Inches		Millimeters		DIM	Inches		Millimeters	
	Min.	Max.	Min.	Max.		Min.	Max.	Min.	Max.
A	0.173	0.189	4.40	4.80	c2	0.049	0.057	1.25	1.45
b	0.026	0.036	0.66	0.91	L2	0.050 REF		1.27 REF	
L4	0.000	0.012	0.00	0.30	D	0.339	0.354	8.60	9.00
c	0.014	0.020	0.36	0.50	e	0.067 REF		1.70 REF	
L1	0.090	0.110	2.29	2.79	L	0.575	0.622	14.6	15.8
E	0.386	0.409	9.80	10.4	θ	0°	8°	0°	8°

Notes: 1.Controlling dimension :millimeter
 2.Maximum lead thickness includes lead finish thickness, and minimum lead thickness is the minimum thickness of base material.
 3.If there is any question with packing specification or packing method, please contact your local CYStek sales office.

Material:
 • Mold Compound: Epoxy resin family, flammability solid burning class: UL94V-0

Recommended wave soldering condition

Product	Peak Temperature	Soldering Time
Pb-free devices	260 +0/-5 °C	5 +1/-1 seconds

Recommended temperature profile for IR reflow

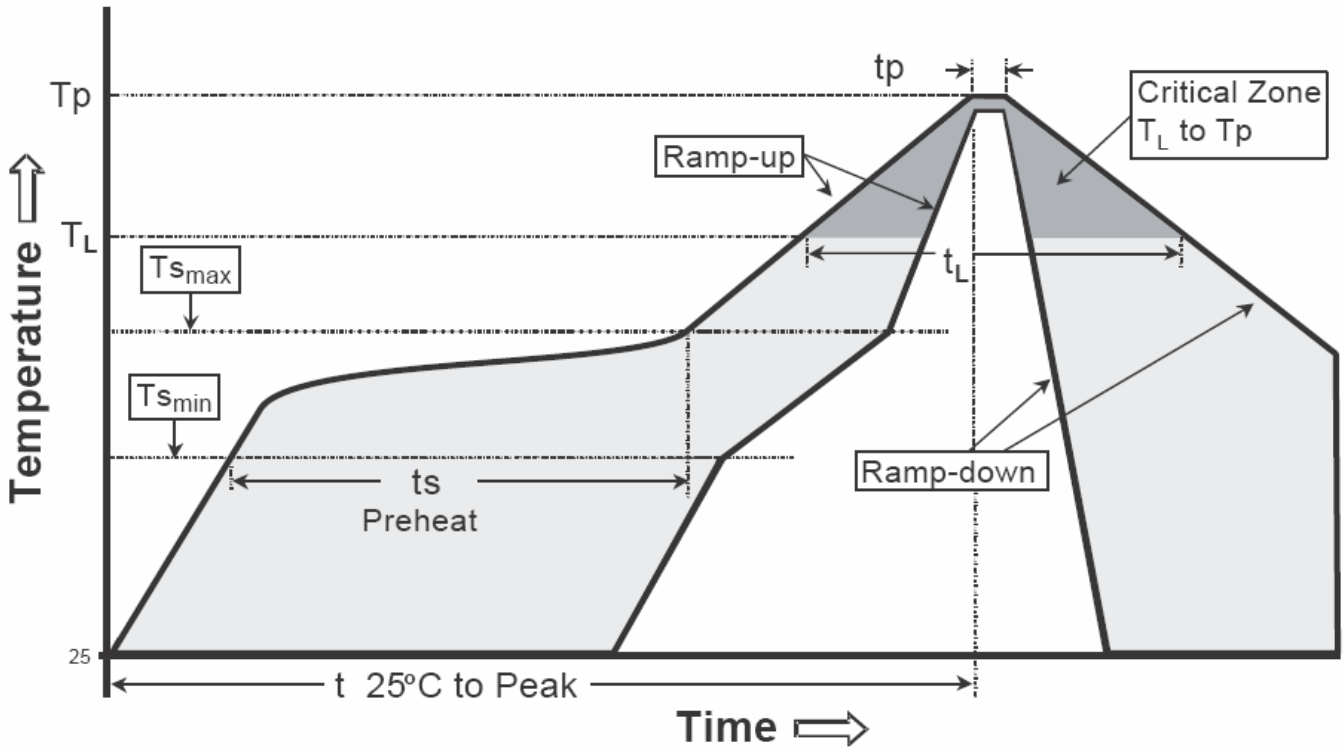

Profile feature	Sn-Pb eutectic Assembly	Pb-free Assembly
Average ramp-up rate (Tsmax to Tp)	3°C/second max.	3°C/second max.
Preheat		
-Temperature Min(Ts min)	100°C	150°C
-Temperature Max(Ts max)	150°C	200°C
-Time(ts min to ts max)	60-120 seconds	60-180 seconds
Time maintained above:		
-Temperature (Tl)	183°C	217°C
- Time (tL)	60-150 seconds	60-150 seconds
Peak Temperature(Tp)	240 +0/-5 °C	260 +0/-5 °C
Time within 5°C of actual peak temperature(tp)	10-30 seconds	20-40 seconds
Ramp down rate	6°C/second max.	6°C/second max.
Time 25 °C to peak temperature	6 minutes max.	8 minutes max.

Note : All temperatures refer to topside of the package, measured on the package body surface.

Important Notice:

- All rights are reserved. Reproduction in whole or in part is prohibited without the prior written approval of CYStek.
- CYStek reserves the right to make changes to its products without notice.
- CYStek **semiconductor products are not warranted to be suitable for use in Life-Support Applications, or systems.**
- CYStek assumes no liability for any consequence of customer product design, infringement of patents, or application assistance.