

# 1A Low Dropout Positive Voltage Regulator

## LM1117-XXXJ3

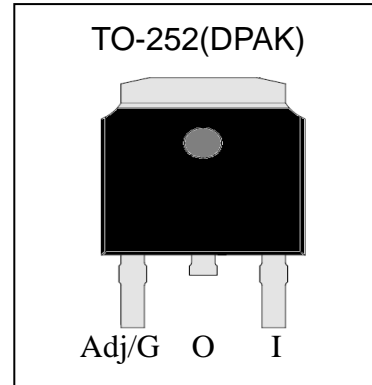

### Features

- Adjustable or Fixed Output
- Output Current of 1A
- Low Dropout, 1.4V max at 1A Output Current
- Good Noise Rejection
- Output Current Limiting
- Built-in Thermal Shutdown
- Fast Transient Response
- Can operate using MLCCs in the capacitance range of 2μF to 10μF

### Description

The LM1117 series of positive adjustable and fixed regulators are designed to provide 1A with high efficiency. All internal circuitry is designed to operate down to 1.4V input to output differential. The product is specifically designed to provide well-regulated supply for low-voltage IC application such as high-speed bus termination and low current 3.3V logic supply, and other applications such as VGA cards.

### Applications

- High Efficiency Linear Regulators
- Post Regulators for Switching Supplies
- Adjustable Power Supply

### Typical Application Data

#### Fixed Voltage Regulator

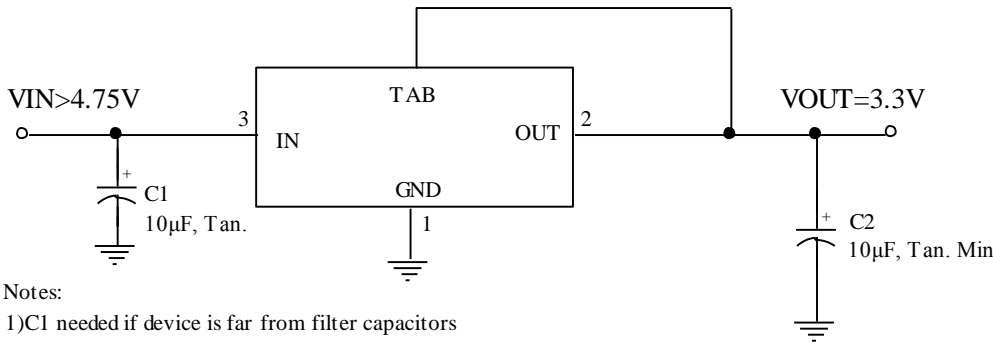

Notes:

- 1)C1 needed if device is far from filter capacitors
- 2)C2 minimum value required for stability

#### Adjustable Voltage Regulator

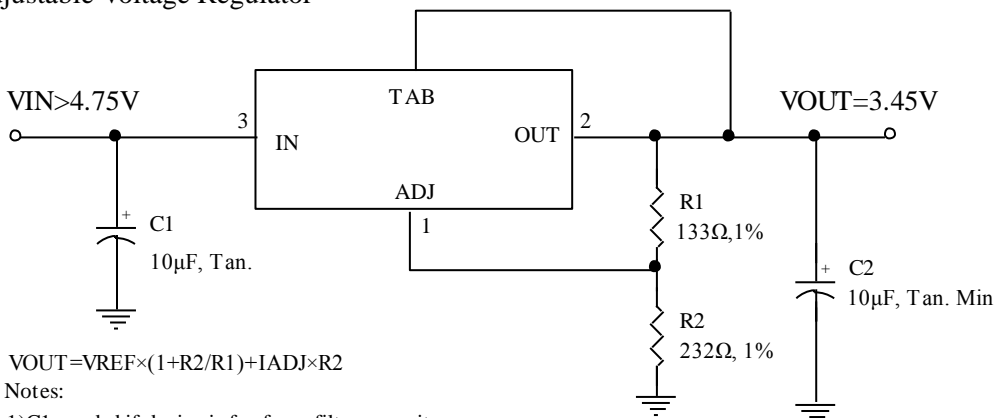

$$V_{OUT} = V_{REF} \times (1 + R2/R1) + I_{ADJ} \times R2$$

Notes:

- 1)C1 needed if device is far from filter capacitors
- 2)C2 minimum value required for stability

## Package Information

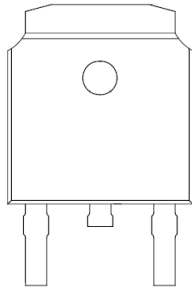

1 2 3

TO-252

Pin	Name
1	ADJ/GND
2	OUTPUT
3	INPUT

## Absolute Maximum Ratings( $T_A=25^{\circ}\text{C}$ )

Symbol	Parameter	Maximum	Units
$P_D$	Power Dissipation@ minimum footprint	850	mW
$V_{IN}$	Input Voltage	20	V
$T_{OPR}$	Operating Junction Temperature Range	-40 ~ +125	$^{\circ}\text{C}$
$T_{STG}$	Storage Temperature	-65 ~ +150	$^{\circ}\text{C}$
$T_{MJ}$	Maximum Junction Temperature	150	$^{\circ}\text{C}$

## Ordering Information

Device	Output Voltage	Package	Shipping
LM1117-ADJJ3-0-T3-G	Adjustable	TO-252 (Pb-free lead plating and halogen-free package)	2500 pcs / Tape & Reel
LM1117-1.5J3-0-T3-G	1.5V		
LM1117-1.8J3-0-T3-G	1.8V		
LM1117-2.5J3-0-T3-G	2.5V		
LM1117-3.3J3-0-T3-G	3.3V		
LM1117-5.0J3-0-T3-G	5.0V		

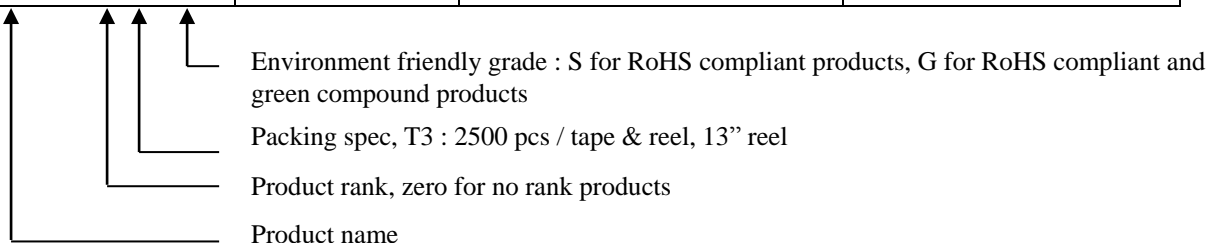

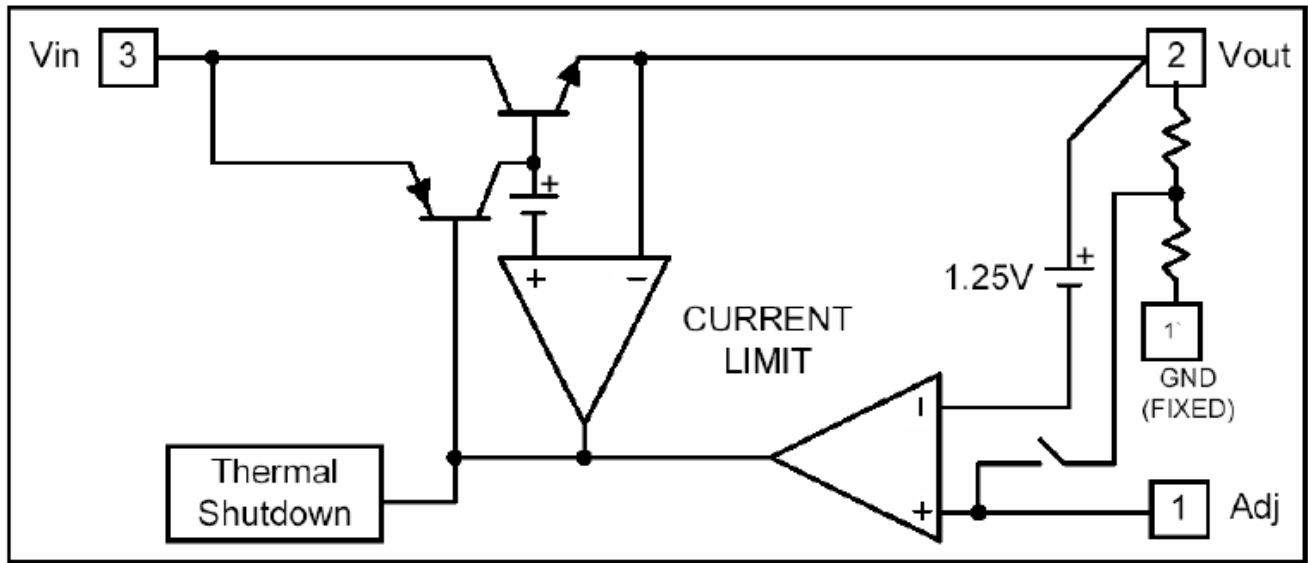
**Block Diagram**

**Electrical Characteristics @  $I_o=10\text{mA}$ ,  $T_J=25^\circ\text{C}$ , unless otherwise specified**

Parameter	Device	Test Conditions	Min	Typ	Max	Units
Reference voltage	Adj version	$V_{IN}-V_{OUT}=1.5\text{V}$	1.225	1.250	1.275	V
Output Voltage	LM1117-1.5	$3.0\text{V}\leq V_{IN}\leq 12\text{V}$	1.470	1.500	1.530	V
	LM1117-1.8	$3.3\text{V}\leq V_{IN}\leq 12\text{V}$	1.764	1.800	1.836	V
	LM1117-2.5	$4.0\text{V}\leq V_{IN}\leq 12\text{V}$	2.450	2.500	2.550	V
	LM1117-3.3	$4.8\text{V}\leq V_{IN}\leq 12\text{V}$	3.235	3.300	3.365	V
	LM1117-5.0	$6.5\text{V}\leq V_{IN}\leq 12\text{V}$	4.900	5.000	5.100	V
Line Regulation	All version	$V_{OUT}+1.5\text{V}\leq V_{IN}\leq 12\text{V}$	-	-	0.2	%
Load Regulation (Note 1, 2)	LM1117-ADJ	$V_{IN}=3.3\text{V}$ , $V_{adj}=0$ , $10\text{mA}\leq I_o\leq 1\text{A}$	-	-	1	%
	LM1117-1.5	$V_{IN}=3.0\text{V}$ , $0\text{mA}\leq I_o\leq 1\text{A}$	-	12	15	mV
	LM1117-1.8	$V_{IN}=3.3\text{V}$ , $0\text{mA}\leq I_o\leq 1\text{A}$	-	15	18	mV
	LM1117-2.5	$V_{IN}=4.0\text{V}$ , $0\text{mA}\leq I_o\leq 1\text{A}$	-	20	25	mV
	LM1117-3.3	$V_{IN}=5.0\text{V}$ , $0\text{mA}\leq I_o\leq 1\text{A}$	-	26	33	mV
	LM1117-5.0	$V_{IN}=8.0\text{V}$ , $0\text{mA}\leq I_o\leq 1\text{A}$	-	40	50	mV
Dropout Voltage ( $V_{IN}-V_{OUT}$ )	All version	$I_o=1\text{A}$ ( $\Delta V_{OUT}=1\% V_{OUT}$ )	-	1.3	1.4	V
Current Limit	All version	$V_{IN}-V_{OUT}=5\text{V}$	1.1	-	-	A
Minimum Load Current	Adj version	$V_{IN}=5\text{V}$	-	2	7	mA
Adjust Pin Current	Adj version	$V_{IN}=12\text{V}$ , $I_o=10\text{mA}$	-	50	100	$\mu\text{A}$
Quiescent Current	Fixed version	$V_{IN}=12\text{V}$ , $I_o=0\text{mA}$	-	-	12	mA
Thermal Regulation	All version	$T_A=25^\circ\text{C}$ , 30ms pulse	-	0.008	0.04	%/W

Ripple Rejection	All version	$f=120\text{Hz}$ , $V_{IN}=V_{OUT}+3\text{V}$ , $I_O=1\text{A}$ , $C_{OUT}=25\mu\text{F}$ tantalum	60	70	-	dB
Temperature Stability	All version	$I_O=10\text{mA}$	-	0.5	-	%
Thermal Resistance, Junction to Ambient (No heat sink, no air flow)	All version		-	117	-	$^{\circ}\text{C}/\text{W}$
Thermal Resistance, Junction to Case	All version	Control Circuitry/ Power transistor	-	15	-	$^{\circ}\text{C}/\text{W}$

Note : 1. See thermal regulation specifications for changes in output voltage due to heating effects. Line and load regulation are measured at a constant junction temperature by low duty cycle pulse testing. Load regulation is measured at the output lead 1/18" from the package.  
 2. Line and load regulation are guaranteed up to the maximum power dissipation of 6.7W. Power dissipation is determined by the difference in input and output and the output current. Guaranteed maximum power dissipation will not be available over the full input/output range.

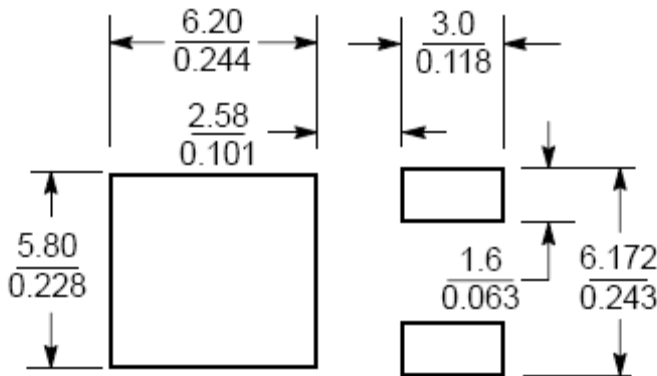
**Recommended soldering footprint**



Unit (  $\frac{\text{mm}}{\text{inch}}$  )

**Typical Characteristics**

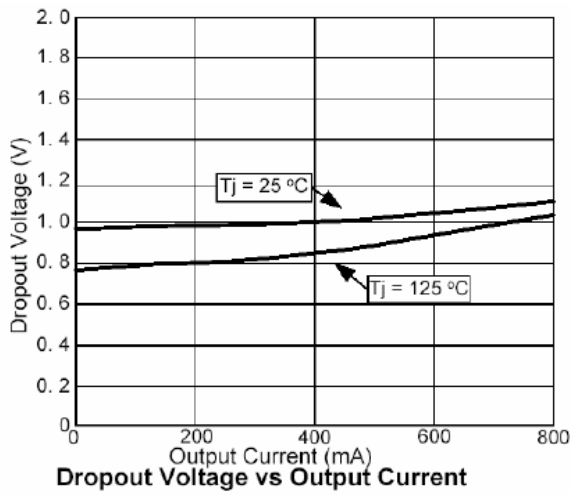

**Dropout Voltage vs Output Current**

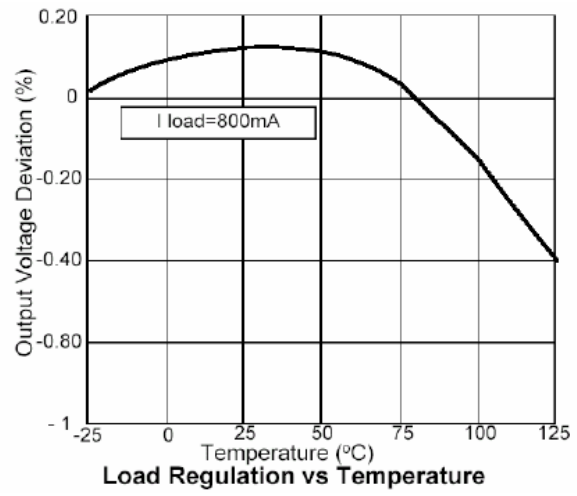

**Load Regulation vs Temperature**

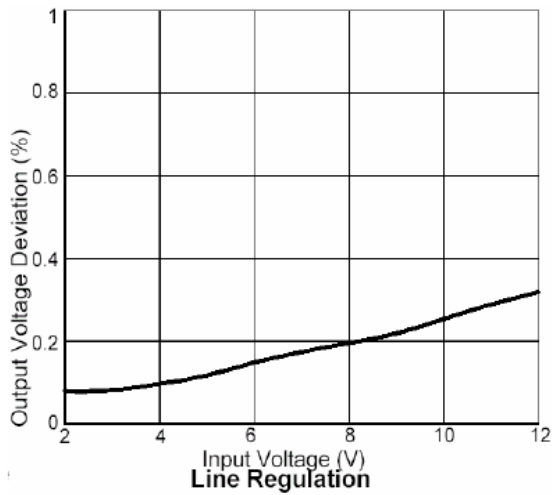

**Line Regulation**

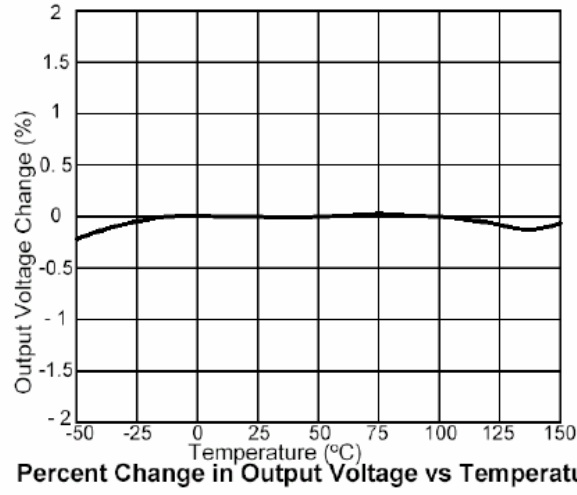

**Percent Change in Output Voltage vs Temperature**

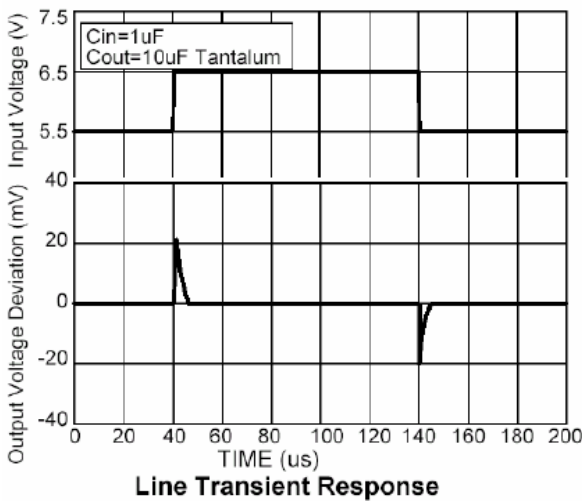

**Line Transient Response**

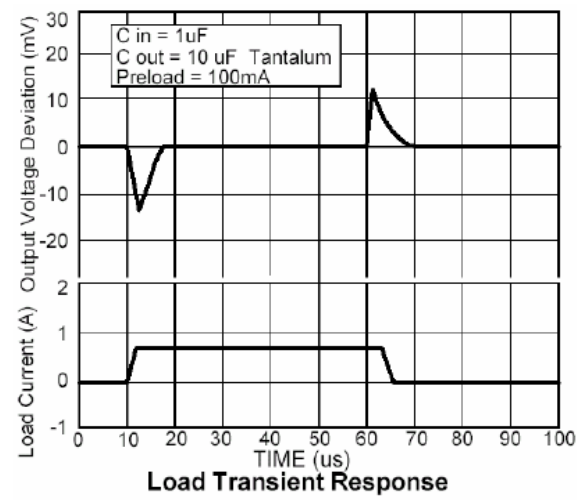

**Load Transient Response**

**Reel Dimension**

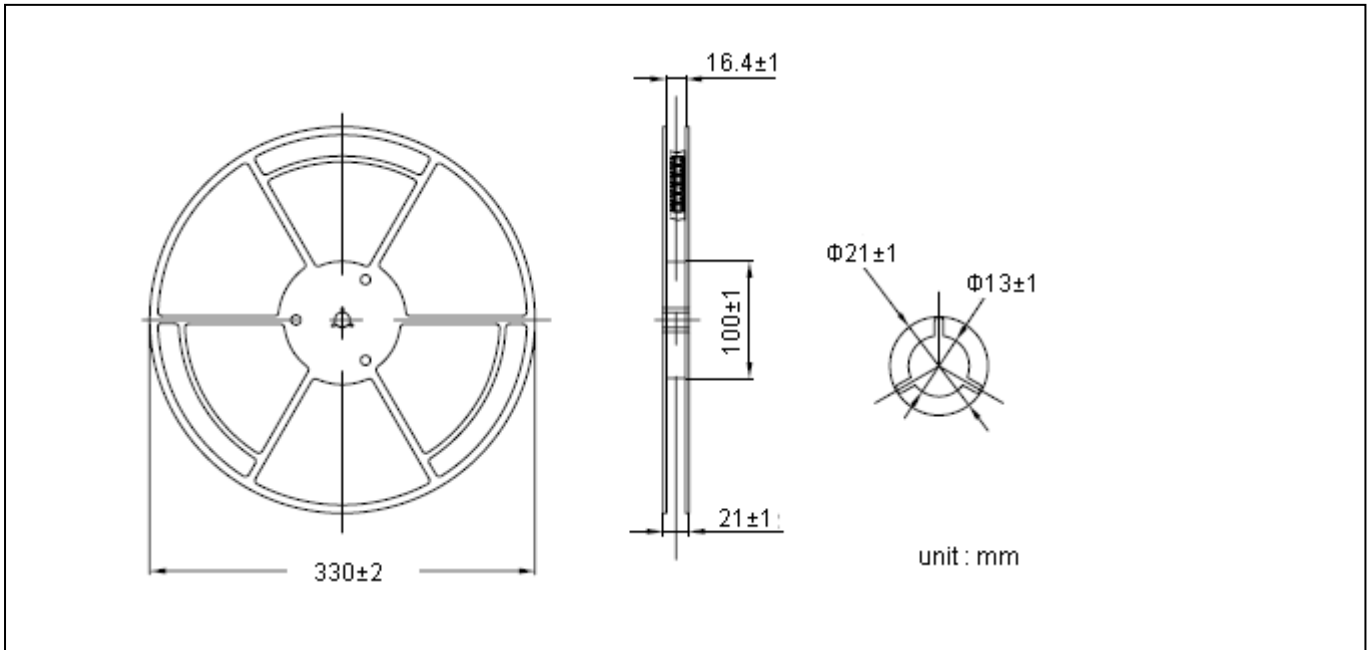

**Carrier Tape Dimension**

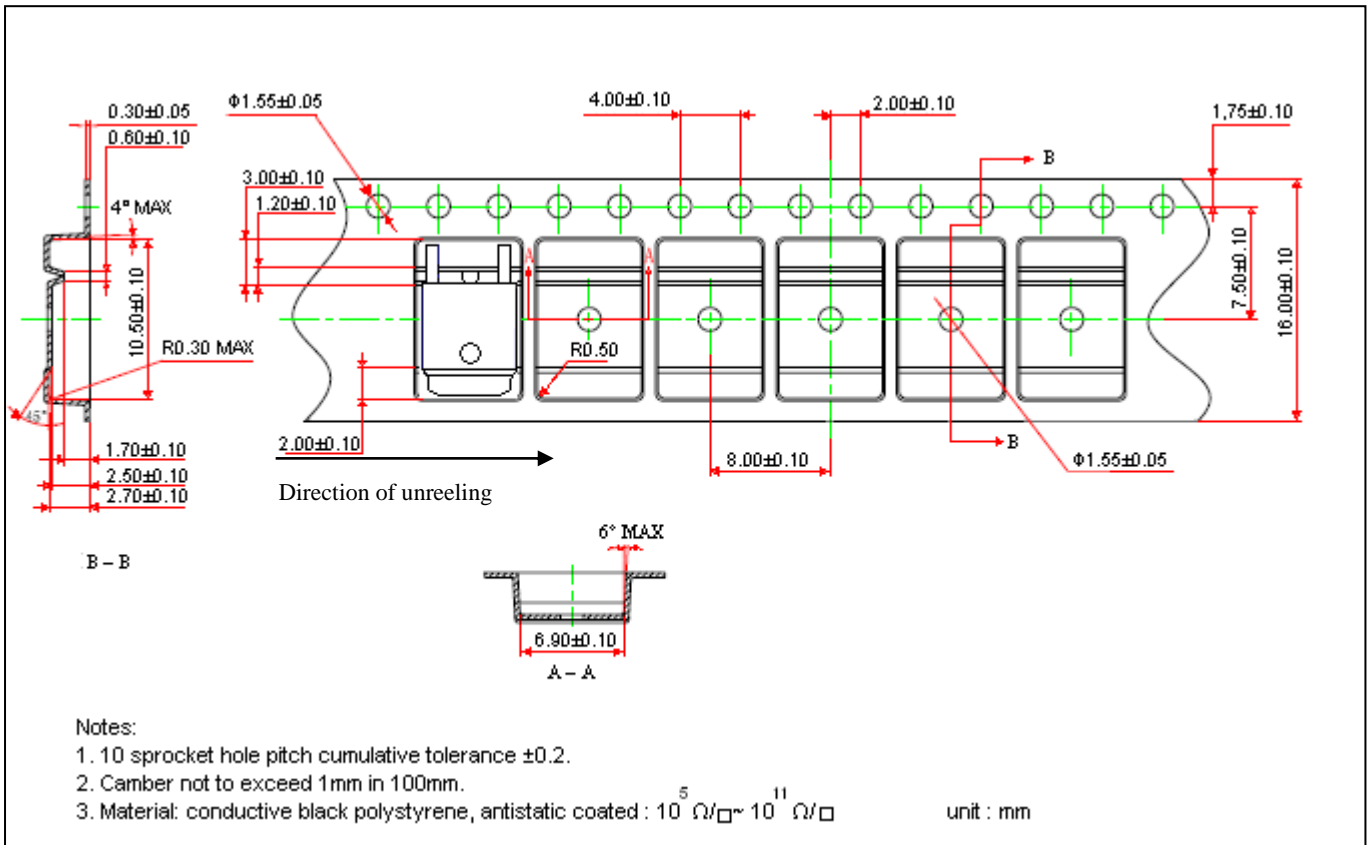

**Recommended wave soldering condition**

Product	Peak Temperature	Soldering Time
Pb-free devices	260 +0/-5 °C	5 +1/-1 seconds

**Recommended temperature profile for IR reflow**

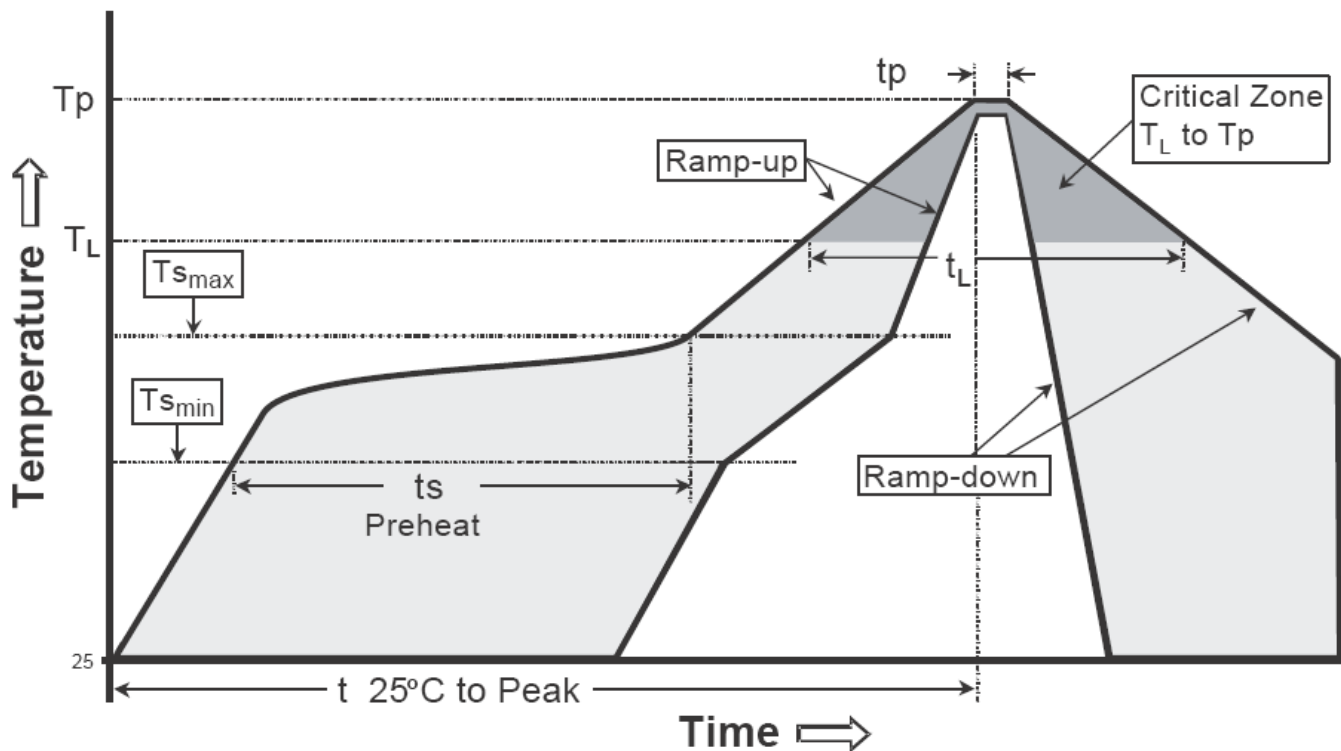

Profile feature	Sn-Pb eutectic Assembly	Pb-free Assembly
Average ramp-up rate (T <sub>smax</sub> to T <sub>p</sub> )	3°C/second max.	3°C/second max.
Preheat		
-Temperature Min(T <sub>s min</sub> )	100°C	150°C
-Temperature Max(T <sub>s max</sub> )	150°C	200°C
-Time(t <sub>s min</sub> to t <sub>s max</sub> )	60-120 seconds	60-180 seconds
Time maintained above:		
-Temperature (T <sub>L</sub> )	183°C	217°C
- Time (t <sub>L</sub> )	60-150 seconds	60-150 seconds
Peak Temperature(T <sub>P</sub> )	240 +0/-5 °C	260 +0/-5 °C
Time within 5°C of actual peak temperature(tp)	10-30 seconds	20-40 seconds
Ramp down rate	6°C/second max.	6°C/second max.
Time 25 °C to peak temperature	6 minutes max.	8 minutes max.

Note : All temperatures refer to topside of the package, measured on the package body surface.

**TO-252 Dimension**

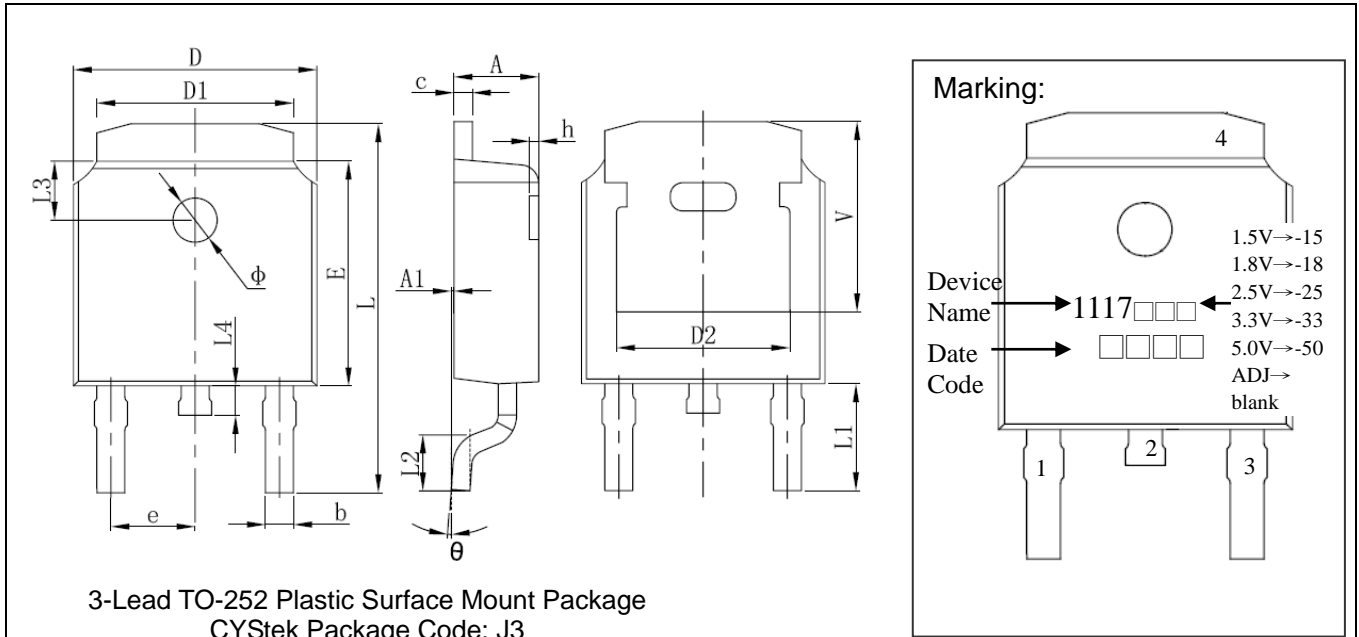

**3-Lead TO-252 Plastic Surface Mount Package**  
 CYStek Package Code: J3

Date Code :  
 First Code : Last digit of Christian Year  
 Second Code : Month Code : Jan→A, Feb→B, Mar→C, Apr→D, May→E, Jun→F, Jul→G, Aug→H, Sep→J, Oct→K, Nov→L, Dec→M  
 Last Two Codes : Production Serial Code. 01~99

Style: Pin 1.Adj/Ground 2.Vout 3.Vin 4.Vout

DIM	Inches		Millimeters		DIM	Inches		Millimeters	
	Min.	Max.	Min.	Max.		Min.	Max.	Min.	Max.
A	0.087	0.094	2.200	2.400	e	0.086	0.094	2.186	2.386
A1	0.000	0.005	0.000	0.127	e1	0.172	0.188	4.372	4.772
B	0.039	0.048	0.990	1.210	H	0.163	REF	4.140	REF
b	0.026	0.034	0.660	0.860	K	0.190	REF	4.830	REF
b1	0.026	0.034	0.660	0.860	L	0.386	0.409	9.800	10.400
C	0.018	0.023	0.460	0.580	L1	0.114	REF	2.900	REF
C1	0.018	0.023	0.460	0.580	L2	0.055	0.067	1.400	1.700
D	0.256	0.264	6.500	6.700	L3	0.024	0.039	0.600	1.000
D1	0.201	0.215	5.100	5.460	P	0.026	REF	0.650	REF
E	0.236	0.244	6.000	6.200	V	0.211	REF	5.350	REF

- Notes: 1.Controlling dimension: millimeters.  
 2.Maximum lead thickness includes lead finish thickness, and minimum lead thickness is the minimum thickness of base material.  
 3.If there is any question with packing specification or packing method, please contact your local CYStek sales office.

**Material:**

- Lead : Pure tin plated.
- Mold Compound: Epoxy resin family, flammability solid burning class: UL94V-0.

**Important Notice:**

- All rights are reserved. Reproduction in whole or in part is prohibited without the prior written approval of CYStek.
- CYStek reserves the right to make changes to its products without notice.
- CYStek **semiconductor products are not warranted to be suitable for use in Life-Support Applications, or systems.**
- CYStek assumes no liability for any consequence of customer product design, infringement of patents, or application assistance.