

# 1A Low Dropout Positive Voltage Regulator

## LM1117E3 Series

### Features

- Adjustable or Fixed Output
- Output Current of 1A
- Low Dropout, 1.4V max at 1A Output Current
- Good Noise Rejection
- Output Current Limiting
- Built-in Thermal Shutdown
- Fast Transient Response
- Can operate using MLCCs in the capacitance range of 2μF to 10μF

### Description

The LM1117 series of positive adjustable and fixed regulators are designed to provide 1A with high efficiency. All internal circuitry is designed to operate down to 1.4V input to output differential. The product is specifically designed to provide well-regulated supply for low-voltage IC application such as high-speed bus termination and low current 3.3V logic supply, and other applications such as VGA cards.

### Applications

- High Efficiency Linear Regulators
- Post Regulators for Switching Supplies
- Adjustable Power Supply

### Typical Application Data

#### Fixed Voltage Regulator

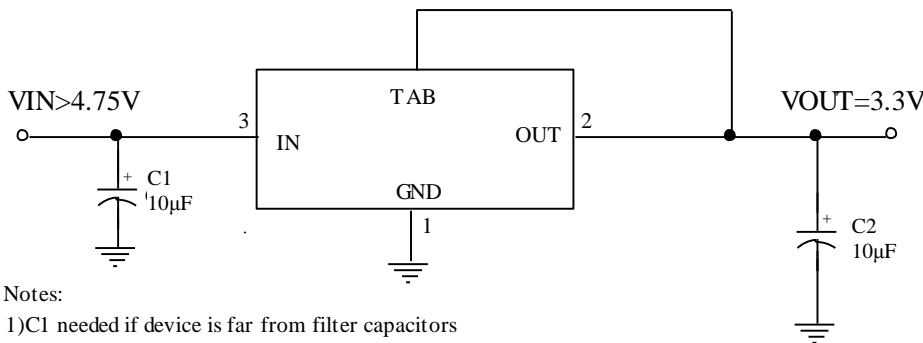

Notes:

- 1)C1 needed if device is far from filter capacitors
- 2)C2 minimum value required for stability

#### Adjustable Voltage Regulator

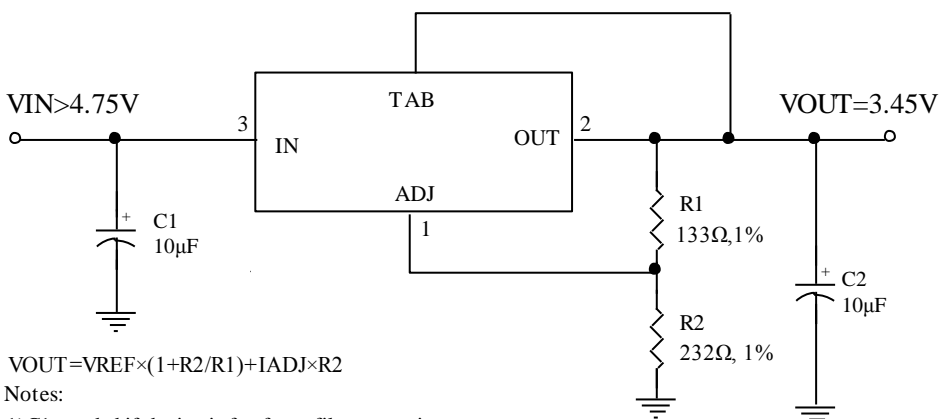

$$V_{OUT} = V_{REF} \times (1 + R2/R1) + I_{ADJ} \times R2$$

Notes:

- 1)C1 needed if device is far from filter capacitors
- 2)C2 minimum value required for stability

## Ordering Information

Device	Package	Shipping
LM1117-XXXE3-0-UB-S	TO-220 (Pb-free lead plating package)	50 pcs/tube, 20 tubes/box, 4 boxes / carton

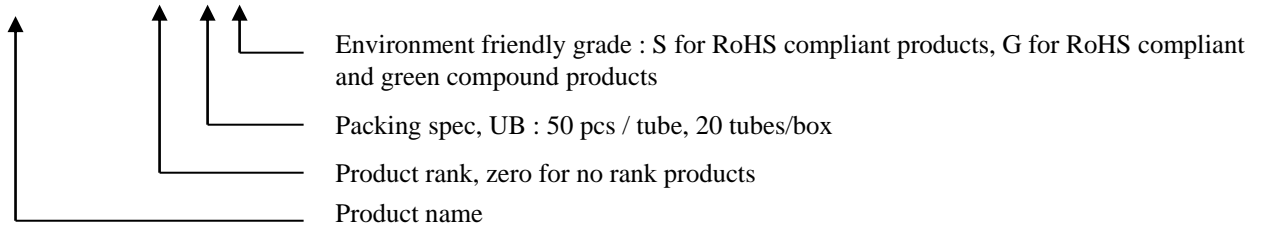

## Package Information

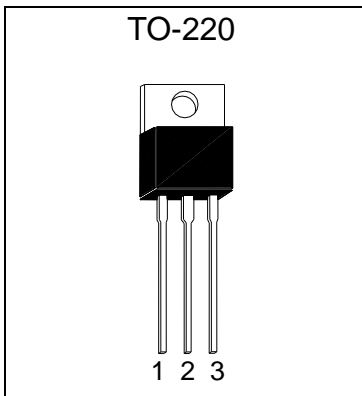

Pin	Name
1	ADJ/GND
2	OUTPUT
3	INPUT

## Absolute Maximum Ratings (T<sub>A</sub>=25°C)

Symbol	Parameter	Maximum	Units
P <sub>D</sub>	Power Dissipation	1.6	W
V <sub>IN</sub>	Input Voltage	20	V
T <sub>OPR</sub>	Operating Junction Temperature Range	-40 ~ +125	°C
T <sub>STG</sub>	Storage Temperature	-65 ~ +150	°C
T <sub>MJ</sub>	Maximum Junction Temperature	150	°C

## Device Selection Guide

Device	Output Voltage
LM1117-ADJ	Adjustable
LM1117-1.5	1.5V
LM1117-1.8	1.8V
LM1117-2.5	2.5V
LM1117-3.3	3.3V
LM1117-5.0	5.0V

**Block Diagram**

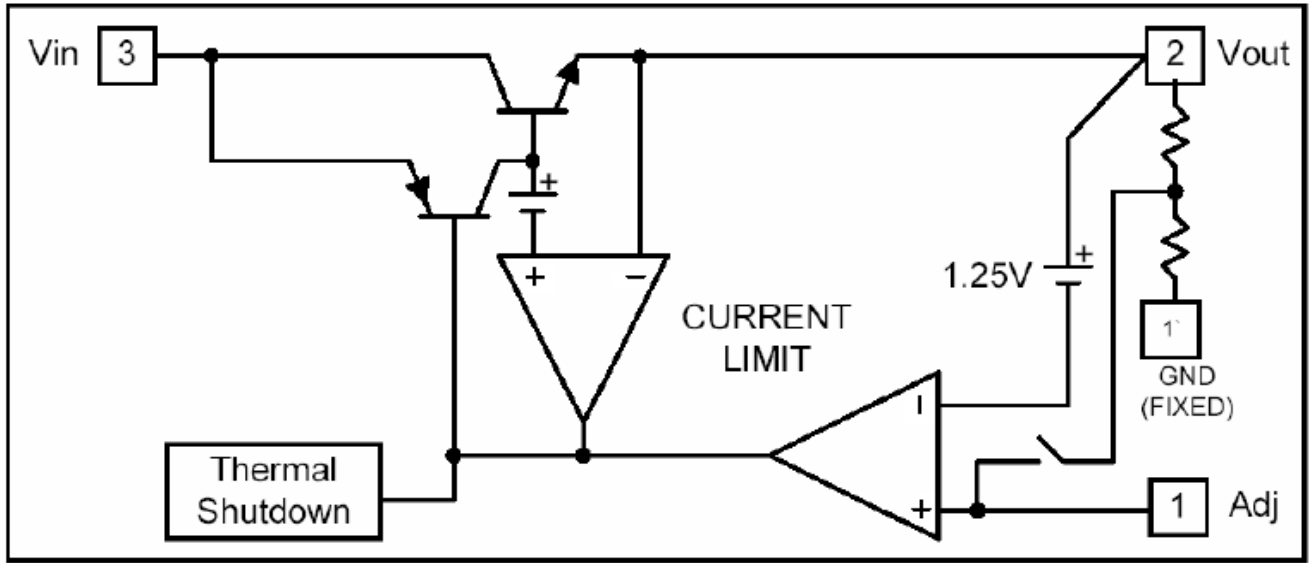

**Electrical Characteristics @  $I_o=10mA, T_J=25^\circ C$ , unless otherwise specified**

Parameter	Device	Test Conditions	Min	Typ	Max	Units
Reference voltage	Adj version	$V_{IN}-V_{OUT}=1.5V$	1.225	1.250	1.275	V
Output Voltage	LM1117-1.5	$3.0V \leq V_{IN} \leq 12V$	1.470	1.500	1.530	V
	LM1117-1.8	$3.3V \leq V_{IN} \leq 12V$	1.764	1.800	1.836	V
	LM1117-2.5	$4.0V \leq V_{IN} \leq 12V$	2.450	2.500	2.550	V
	LM1117-3.3	$4.8V \leq V_{IN} \leq 12V$	3.235	3.300	3.365	V
	LM1117-5.0	$6.5V \leq V_{IN} \leq 12V$	4.900	5.000	5.100	V
Line Regulation	All version	$V_{OUT}+1.5V \leq V_{IN} \leq 12V$	-	-	0.2	%
Load Regulation (Note 1, 2)	LM1117-ADJ	$V_{IN}=3.3V, V_{adj}=0, 10mA \leq I_o \leq 1A$	-	-	1	%
	LM1117-1.5	$V_{IN}=3.0V, 0mA \leq I_o \leq 1A$	-	12	15	mV
	LM1117-1.8	$V_{IN}=3.3V, 0mA \leq I_o \leq 1A$	-	15	18	mV
	LM1117-2.5	$V_{IN}=4.0V, 0mA \leq I_o \leq 1A$	-	20	25	mV
	LM1117-3.3	$V_{IN}=5.0V, 0mA \leq I_o \leq 1A$	-	26	33	mV
	LM1117-5.0	$V_{IN}=8.0V, 0mA \leq I_o \leq 1A$	-	40	50	mV
Dropout Voltage ( $V_{IN}-V_{OUT}$ )	All version	$I_o=1A (\Delta V_{OUT}=1\% V_{OUT})$	-	1.3	1.4	V
Current Limit	All version	$V_{IN}-V_{OUT}=5V$	1.1	-	-	A
Minimum Load Current	Adj version	$V_{IN}=5V$	-	2	7	mA
Adjust Pin Current	Adj version	$V_{IN}=12V, I_o=10mA$	-	50	100	$\mu A$
Quiescent Current	Fixed version	$V_{IN}=12V, I_o=0mA$	-	-	12	mA



Thermal Regulation	All version	$T_A=25^{\circ}\text{C}$ , 30ms pulse	-	0.008	0.04	%/W
Ripple Rejection	All version	$f=120\text{Hz}$ , $V_{IN}=V_{OUT}+3\text{V}$ , $I_O=1\text{A}$ , $C_{OUT}=25\mu\text{F}$ tantalum	60	70	-	dB
Temperature Stability	All version	$I_O=10\text{mA}$	-	0.5	-	%
Thermal Resistance, Junction to Ambient (No heat sink, no air flow)	All version		-	62.5	-	$^{\circ}\text{C}/\text{W}$
Thermal Resistance, Junction to Case	All version	Control Circuitry/ Power transistor	-	0.65/2.7	-	$^{\circ}\text{C}/\text{W}$

- Note : 1. See thermal regulation specifications for changes in output voltage due to heating effects. Line and load regulation are measured at a constant junction temperature by low duty cycle pulse testing. Load regulation is measured at the output lead 1/18" from the package.
2. Line and load regulation are guaranteed up to the maximum power dissipation of 15W. Power dissipation is determined by the difference in input and output and the output current. Guaranteed maximum power dissipation will not be available over the full input/output range.

**Typical Characteristics**

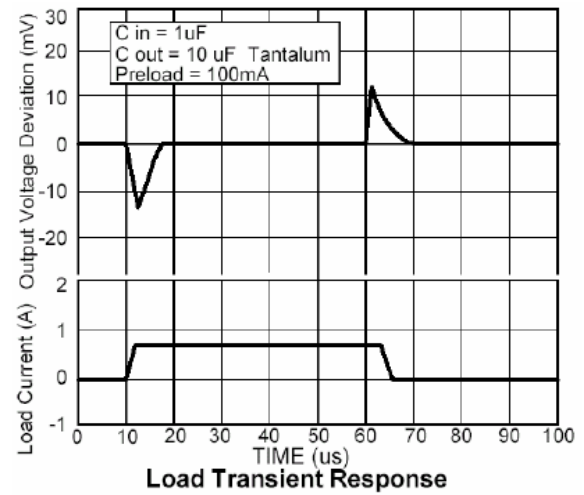
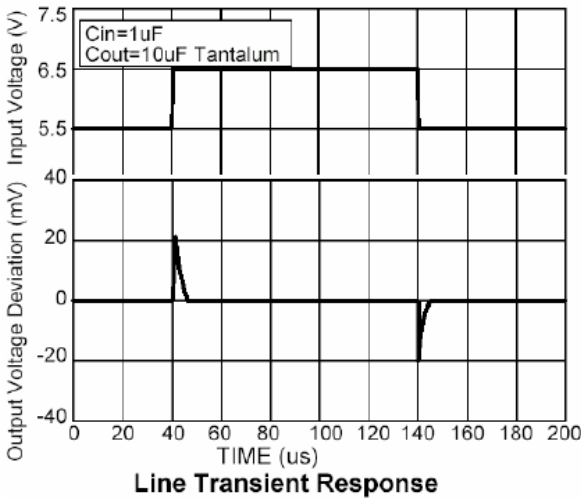
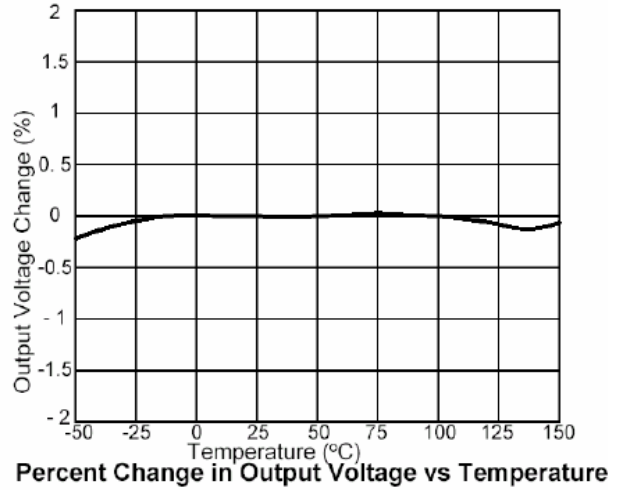
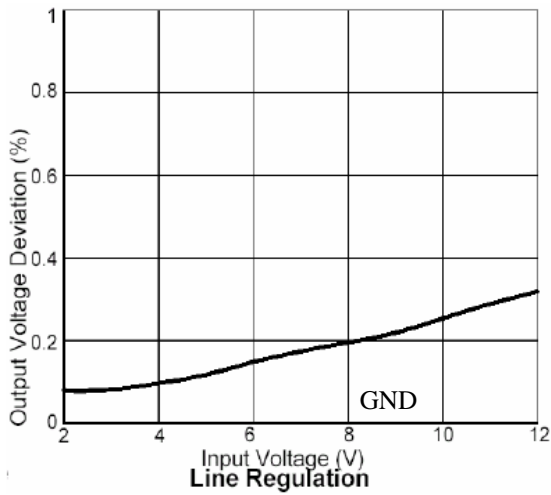
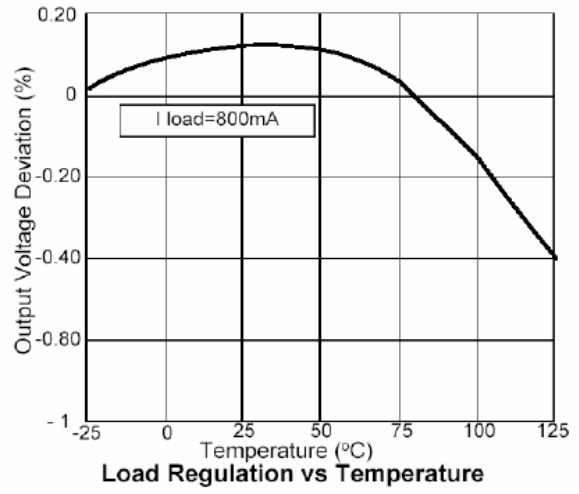
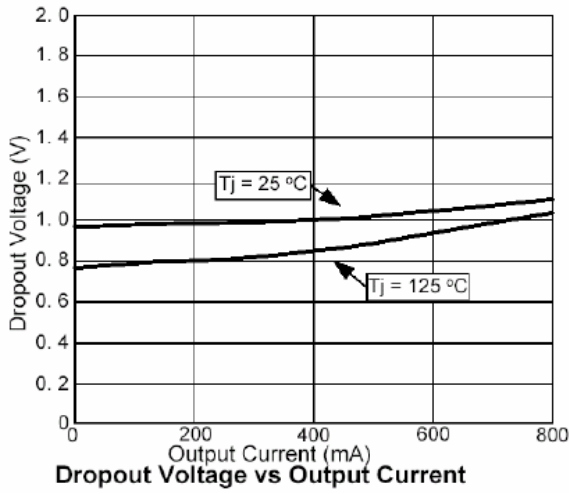

**Recommended wave soldering condition**

Product	Peak Temperature	Soldering Time
Pb-free devices	260 +0/-5 °C	5 +1/-1 seconds

**Recommended temperature profile for IR reflow**

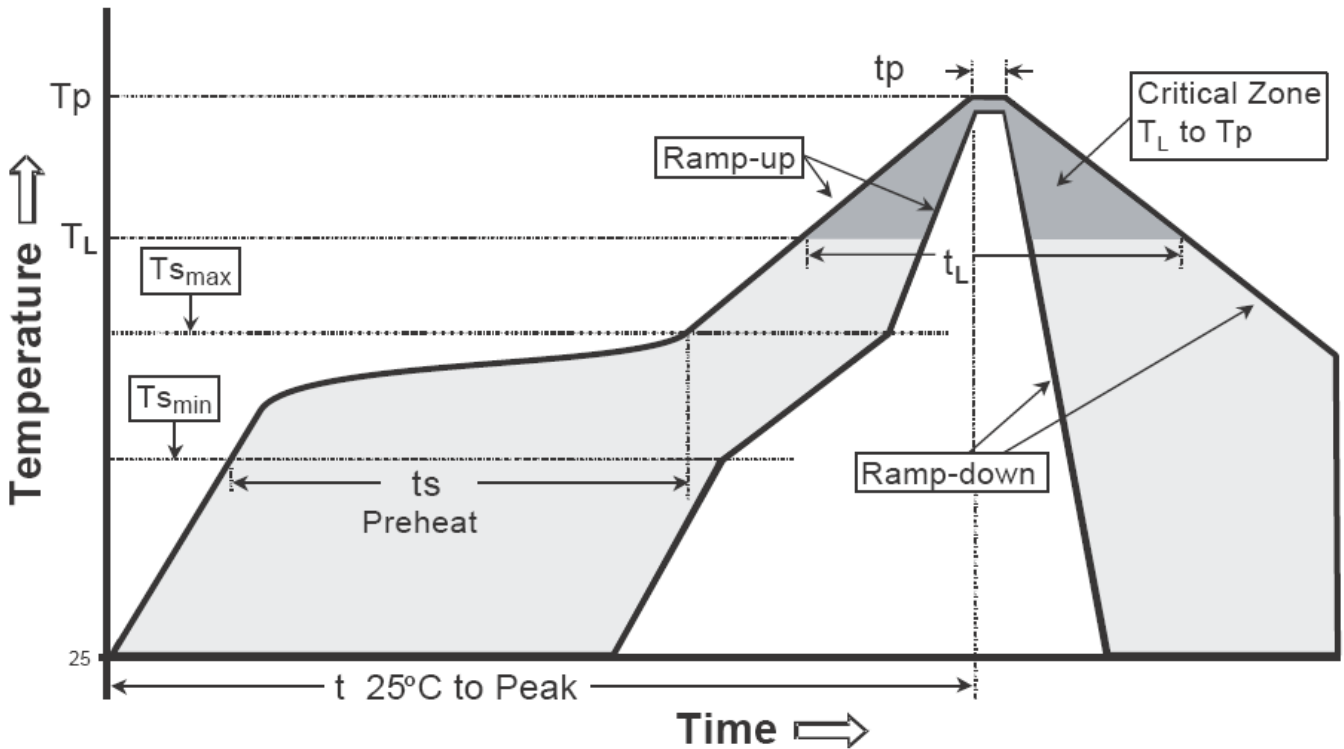

Profile feature	Sn-Pb eutectic Assembly	Pb-free Assembly
Average ramp-up rate (T <sub>smax</sub> to T <sub>p</sub> )	3°C/second max.	3°C/second max.
Preheat		
-Temperature Min(T <sub>s min</sub> )	100°C	150°C
-Temperature Max(T <sub>s max</sub> )	150°C	200°C
-Time(t <sub>s min</sub> to t <sub>s max</sub> )	60-120 seconds	60-180 seconds
Time maintained above:		
-Temperature (T <sub>L</sub> )	183°C	217°C
- Time (t <sub>L</sub> )	60-150 seconds	60-150 seconds
Peak Temperature(T <sub>p</sub> )	240 +0/-5 °C	260 +0/-5 °C
Time within 5°C of actual peak temperature(tp)	10-30 seconds	20-40 seconds
Ramp down rate	6°C/second max.	6°C/second max.
Time 25 °C to peak temperature	6 minutes max.	8 minutes max.

Note : All temperatures refer to topside of the package, measured on the package body surface.

**TO-220 Dimension**

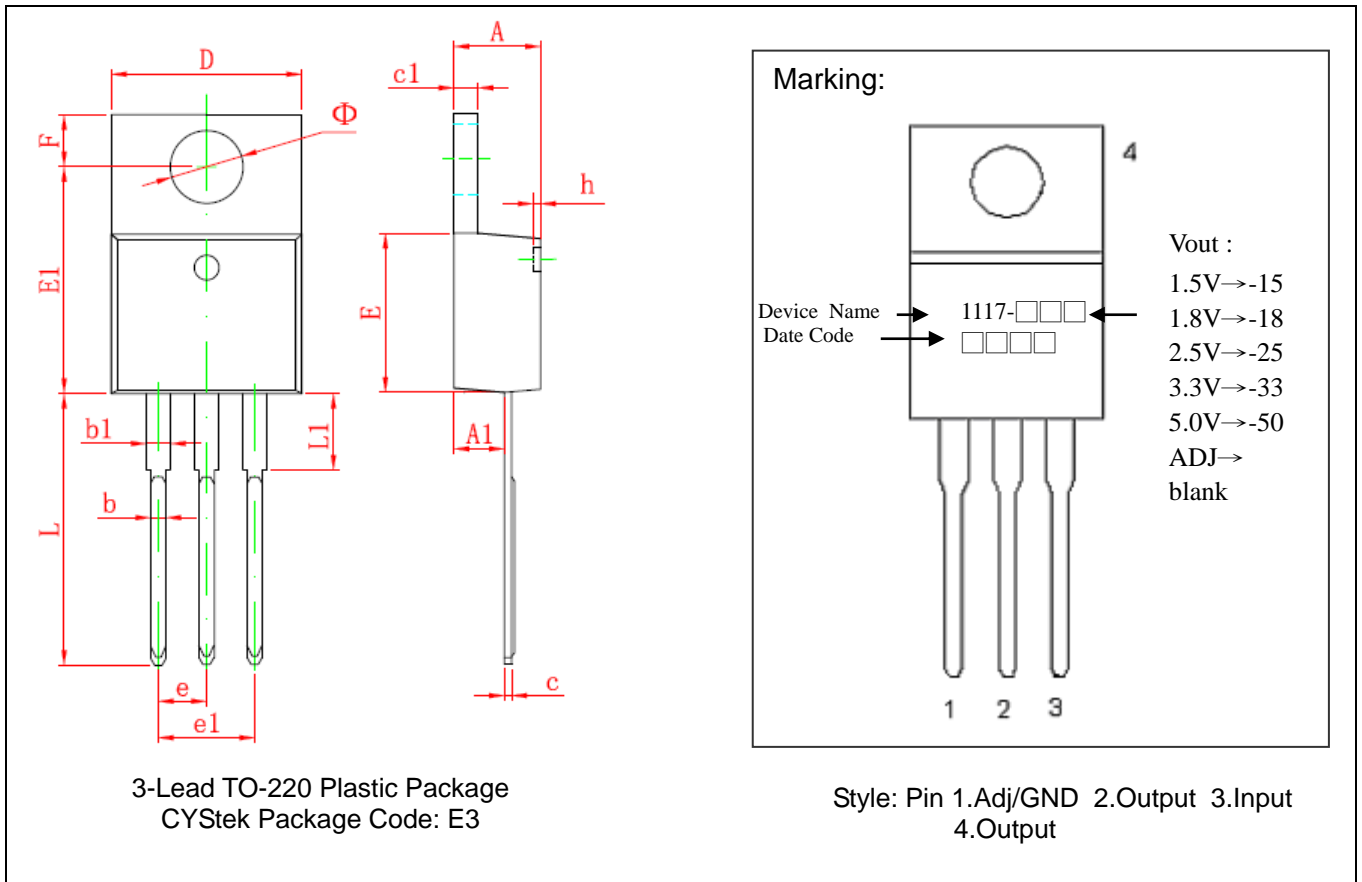

**3-Lead TO-220 Plastic Package**  
 CYStek Package Code: E3

**Marking:**

Device Name → 1117-□□□ ←  
 Date Code → □□□□ ←

Vout :  
 1.5V → -15  
 1.8V → -18  
 2.5V → -25  
 3.3V → -33  
 5.0V → -50  
 ADJ →  
 blank

Style: Pin 1.Adj/GND 2.Output 3.Input 4.Output

\*: Typical

DIM	Millimeters		Inches		DIM	Millimeters		Inches	
	Min.	Max.	Min.	Max.		Min.	Max.	Min.	Max.
A	4.470	4.670	0.176	0.184	E1	12.060	12.460	0.475	0.491
A1	2.520	2.820	0.099	0.111	e	2.540*		0.100*	
b	0.710	0.910	0.028	0.036	e1	4.980	5.180	0.196	0.204
b1	1.170	1.370	0.046	0.054	F	2.590	2.890	0.102	0.114
c	0.310	0.530	0.012	0.021	h	0.000	0.300	0.000	0.012
c1	1.170	1.370	0.046	0.054	L	13.400	13.800	0.528	0.543
D	10.010	10.310	0.394	0.406	L1	3.560	3.960	0.140	0.156
E	8.500	8.900	0.335	0.350	Φ	3.735	3.935	0.147	0.155

Notes: 1.Controlling dimension: millimeters.  
 2.Maximum lead thickness includes lead finish thickness, and minimum lead thickness is the minimum thickness of base material.  
 3.If there is any question with packing specification or packing method, please contact your local CYStek sales office.

**Material:**

- Lead: Pure tin plated.
- Mold Compound: Epoxy resin family, flammability solid burning class: UL94V-0.

**Important Notice:**

- All rights are reserved. Reproduction in whole or in part is prohibited without the prior written approval of CYStek.
- CYStek reserves the right to make changes to its products without notice.
- CYStek **semiconductor products are not warranted for use in Life-Support Applications, or systems.**
- CYStek assumes no liability for any consequence of customer product design, infringement of patents, or application assistance.