

1A Low Dropout Positive Voltage Regulator

LM1117L3 series

Features

- Adjustable or Fixed Output
- Output Current of 1A
- Low Dropout, 1.4V max at 1A Output Current
- Good Noise Rejection
- Output Current Limiting
- Built-in Thermal Shutdown
- Fast Transient Response
- Pb-free lead plating package
- Can operate using MLCCs in the capacitance range of 2μF to 10μF

Description

The LM1117 series of positive adjustable and fixed regulators are designed to provide 1A with high efficiency. All internal circuitry is designed to operate down to 1.4V input to output differential. The product is specifically designed to provide well-regulated supply for low-voltage IC application such as high-speed bus termination and low current 3.3V logic supply, and other applications such as VGA cards.

Applications

- High Efficiency Linear Regulators
- Post Regulators for Switching Supplies
- Adjustable Power Supply

Typical Application Data

Fixed Voltage Regulator

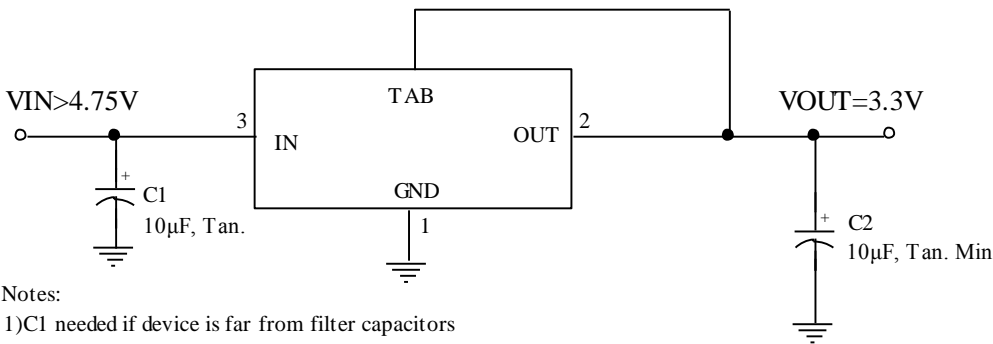

Notes:

- 1)C1 needed if device is far from filter capacitors
- 2)C2 minimum value required for stability

Adjustable Voltage Regulator

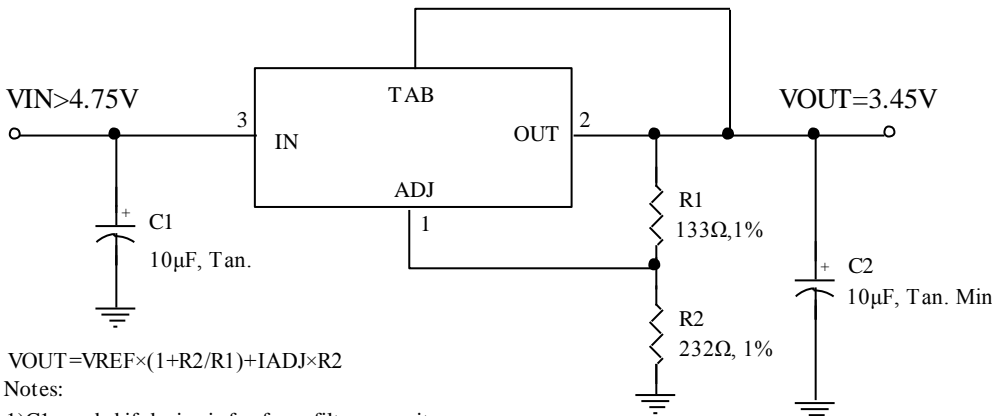

$$V_{OUT} = V_{REF} \times (1 + R_2/R_1) + I_{ADJ} \times R_2$$

Notes:

- 1)C1 needed if device is far from filter capacitors
- 2)C2 minimum value required for stability

Package Information

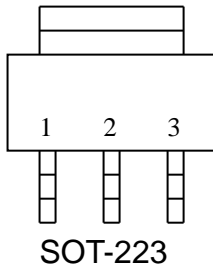

Pin	Name
1	ADJ/GND
2	OUTPUT
3	INPUT

Absolute Maximum Ratings(T_A=25°C)

Symbol	Parameter	Maximum	Units
P _D	Power Dissipation	850	mW
V _{IN}	Input Voltage	20	V
T _{OPR}	Operating Junction Temperature Range	-40 ~ +125	°C
T _{STG}	Storage Temperature	-65 ~ +150	°C
T _{MJ}	Maximum Junction Temperature	150	°C

Ordering Information

Device	Output Voltage	Package	Shipping
LM1117-ADJL3-0-T3-G	Adjustable	SOT-223 (pb-free lead plating and halogen-free package)	2500 pcs/ tape & reel
LM1117-1.5L3-0-T3-G	1.5V		
LM1117-1.8L3-0-T3-G	1.8V		
LM1117-2.5L3-0-T3-G	2.5V		
LM1117-3.3L3-0-T3-G	3.3V		
LM1117-5.0L3-0-T3-G	5.0V		

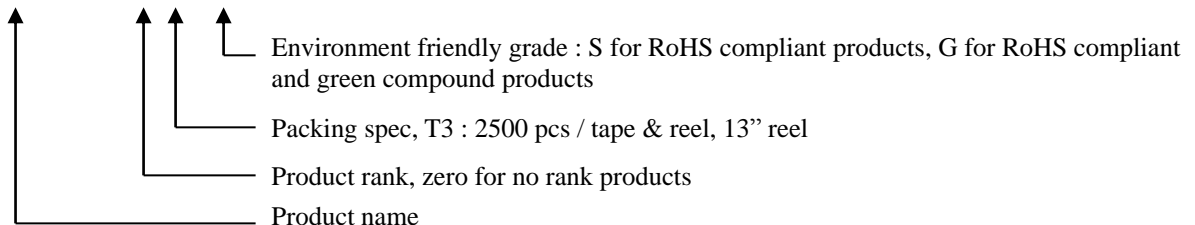

Block Diagram

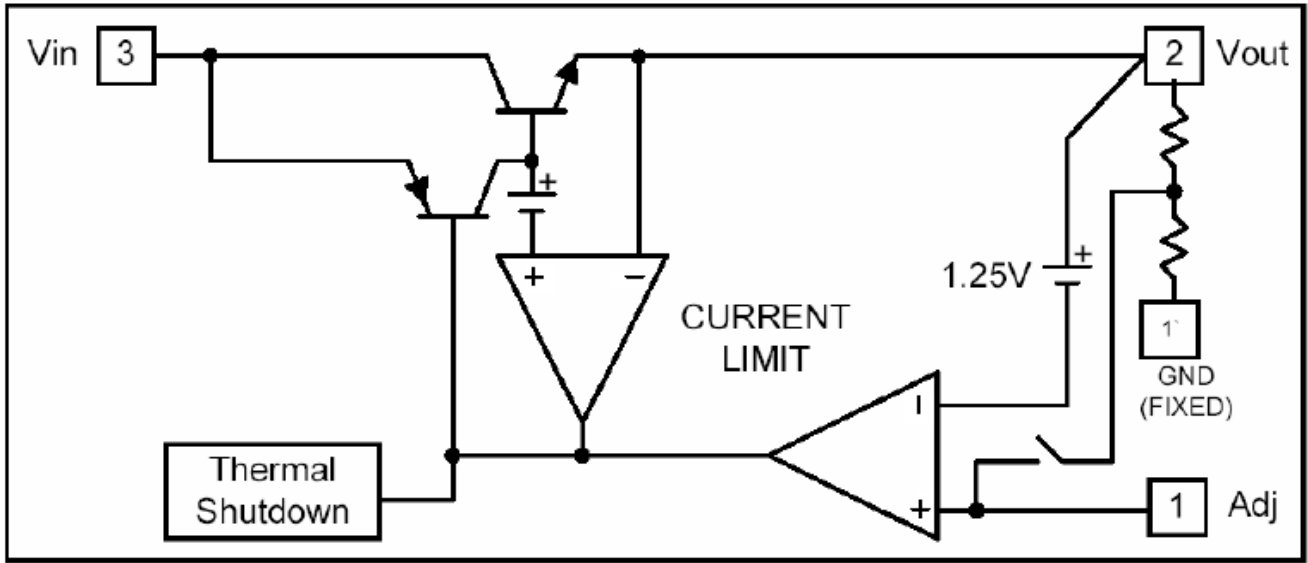

Electrical Characteristics @ $I_o=10mA, T_J=25^\circ C$, unless otherwise specified

Parameter	Device	Test Conditions	Min	Typ	Max	Units
Reference voltage	Adj version	$V_{IN}-V_{OUT}=1.5V$	1.225	1.250	1.275	V
Output Voltage	LM1117-1.5	$3.0V \leq V_{IN} \leq 12V$	1.470	1.500	1.530	V
	LM1117-1.8	$3.3V \leq V_{IN} \leq 12V$	1.764	1.800	1.836	V
	LM1117-2.5	$4.0V \leq V_{IN} \leq 12V$	2.450	2.500	2.550	V
	LM1117-3.3	$4.8V \leq V_{IN} \leq 12V$	3.235	3.300	3.365	V
	LM1117-5.0	$6.5V \leq V_{IN} \leq 12V$	4.900	5.000	5.100	V
Line Regulation	All version	$V_{OUT}+1.5V \leq V_{IN} \leq 12V$	-	-	0.2	%
Load Regulation (Note 1, 2)	LM1117-ADJ	$V_{IN}=3.3V, V_{adj}=0, 10mA \leq I_o \leq 1A$	-	-	1	%
	LM1117-1.5	$V_{IN}=3.0V, 0mA \leq I_o \leq 1A$	-	12	15	mV
	LM1117-1.8	$V_{IN}=3.3V, 0mA \leq I_o \leq 1A$	-	15	18	mV
	LM1117-2.5	$V_{IN}=4.0V, 0mA \leq I_o \leq 1A$	-	20	25	mV
	LM1117-3.3	$V_{IN}=5.0V, 0mA \leq I_o \leq 1A$	-	26	33	mV
	LM1117-5.0	$V_{IN}=8.0V, 0mA \leq I_o \leq 1A$	-	40	50	mV
Dropout Voltage ($V_{IN}-V_{OUT}$)	All version	$I_o=1A (\Delta V_{OUT}=1\% V_{OUT})$	-	1.3	1.4	V
Current Limit	All version	$V_{IN}-V_{OUT}=5V$	1.1	-	-	A
Minimum Load Current	Adj version	$V_{IN}=5V$	-	2	7	mA
Adjust Pin Current	Adj version	$V_{IN}=12V, I_o=10mA$	-	50	100	μA
Quiescent Current	Fixed version	$V_{IN}=12V, I_o=0mA$	-	-	12	mA

Thermal Regulation	All version	$T_A=25^{\circ}\text{C}$, 30ms pulse	-	0.008	0.04	%/W
Ripple Rejection	All version	$f=120\text{Hz}$, $V_{IN}=V_{OUT}+3\text{V}$, $I_O=1\text{A}$, $C_{OUT}=25\mu\text{F}$ tantalum	60	70	-	dB
Temperature Stability	All version	$I_O=10\text{mA}$	-	0.5	-	%
Thermal Resistance, Junction to Ambient(No heat sink, no air flow)	All version		-	117	-	$^{\circ}\text{C}/\text{W}$
Thermal Resistance, Junction to Case	All version	Control Circuitry/ Power transistor	-	15	-	$^{\circ}\text{C}/\text{W}$

- Note : 1. See thermal regulation specifications for changes in output voltage due to heating effects. Line and load regulation are measured at a constant junction temperature by low duty cycle pulse testing. Load regulation is measured at the output lead 1/18" from the package.
2. Line and load regulation are guaranteed up to the maximum power dissipation of 6.6W. Power dissipation is determined by the difference in input and output and the output current. Guaranteed maximum power dissipation will not be available over the full input/output range.

Recommended soldering footprint

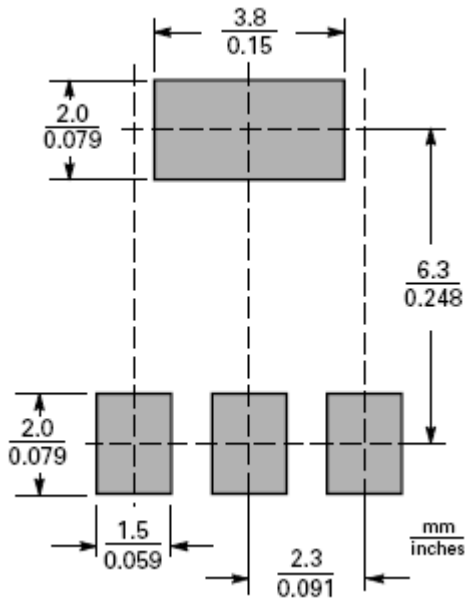

Typical Characteristics

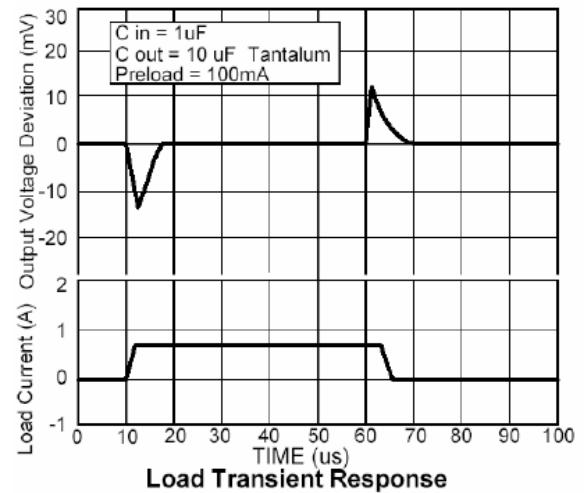
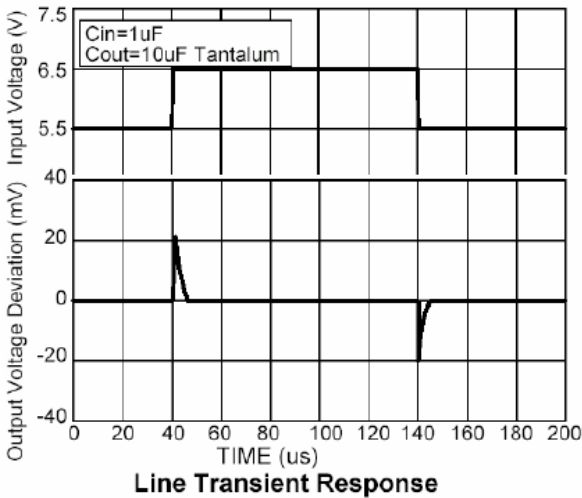
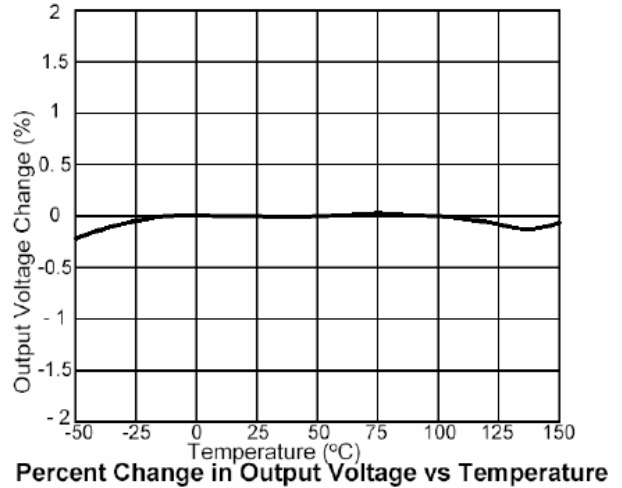
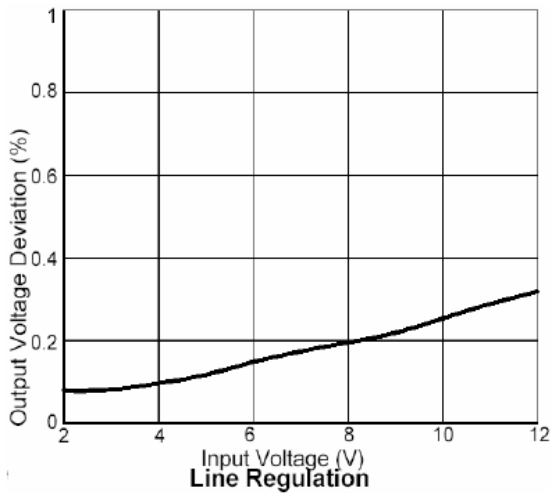
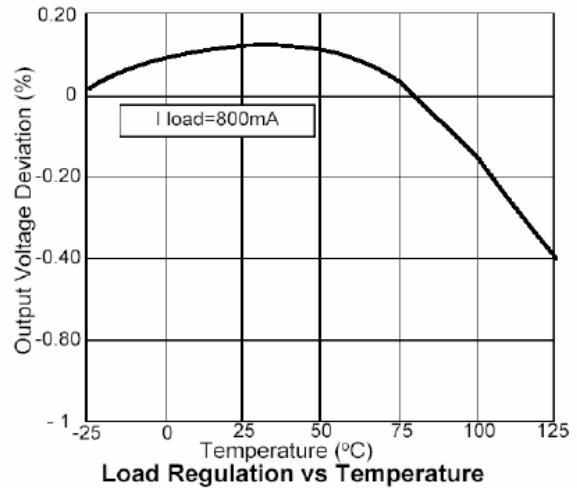
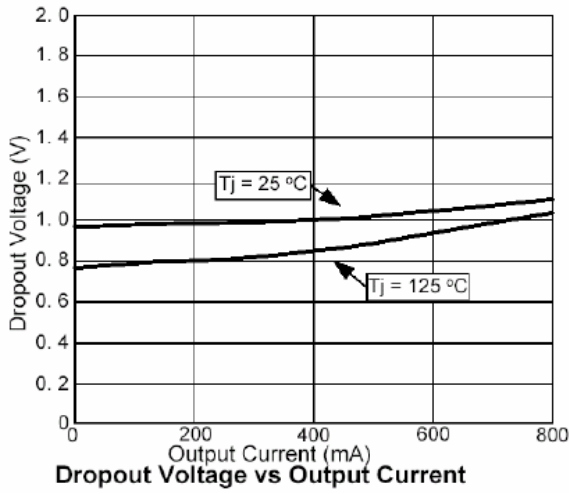

Reel Dimension

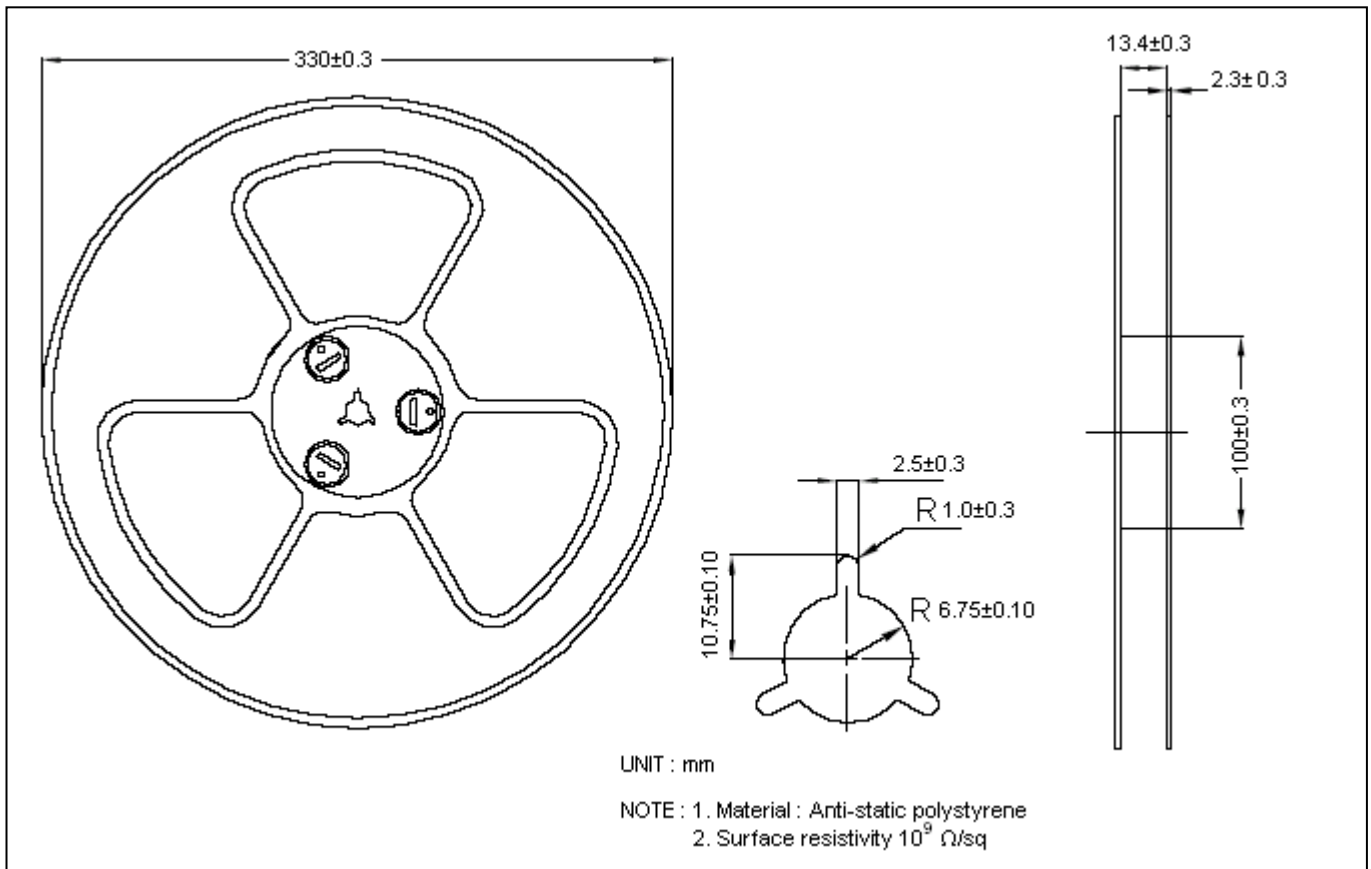

Carrier Tape Dimension

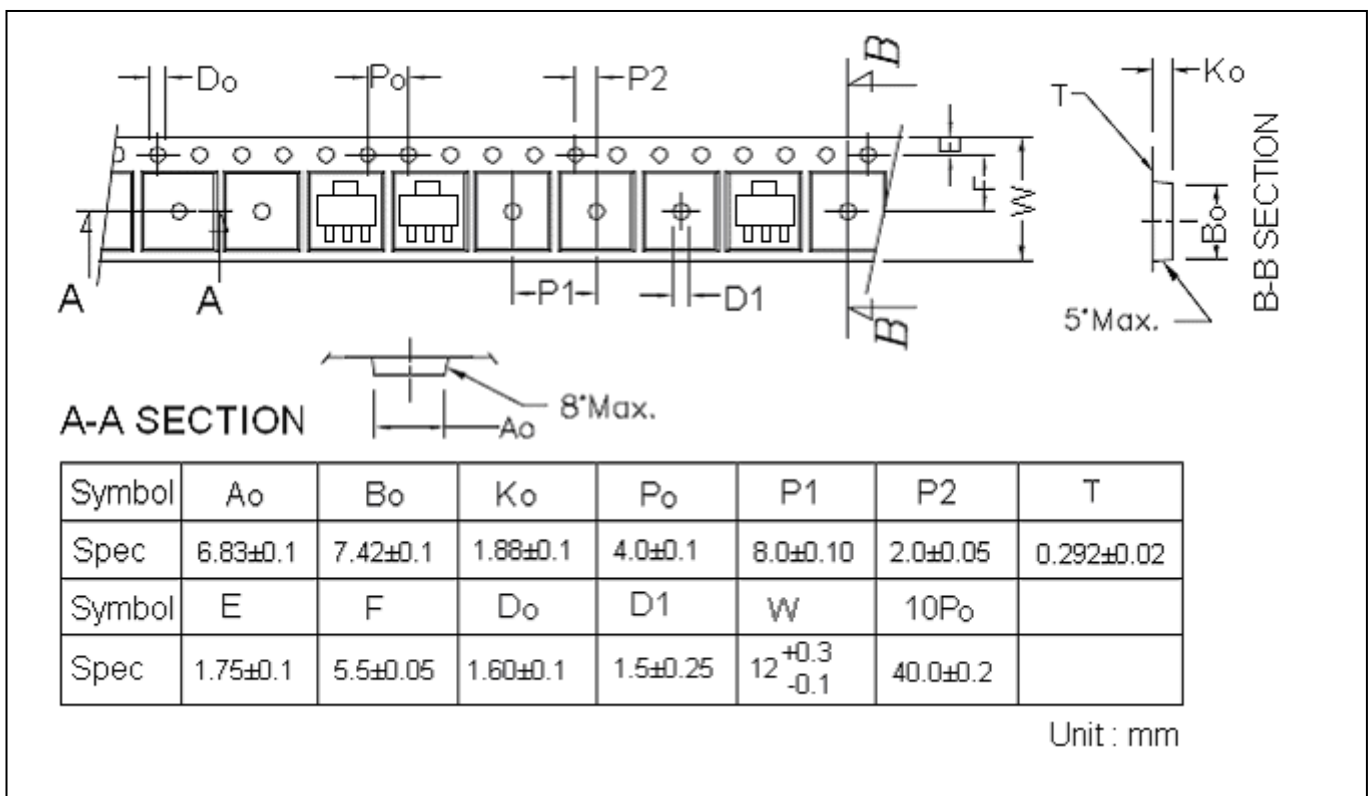

Recommended wave soldering condition

Product	Peak Temperature	Soldering Time
Pb-free devices	260 +0/-5 °C	5 +1/-1 seconds

Recommended temperature profile for IR reflow

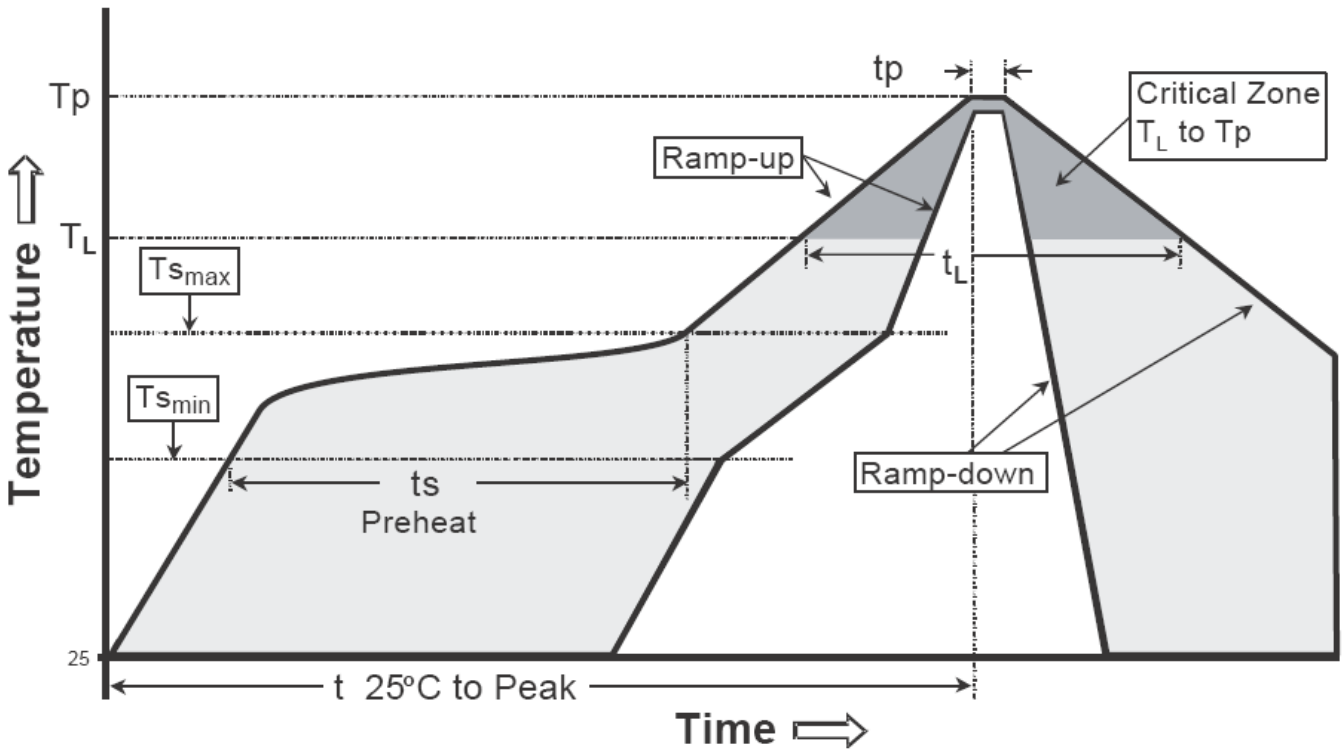

Profile feature	Sn-Pb eutectic Assembly	Pb-free Assembly
Average ramp-up rate (T _{smax} to T _p)	3°C/second max.	3°C/second max.
Preheat		
-Temperature Min(T _{s min})	100°C	150°C
-Temperature Max(T _{s max})	150°C	200°C
-Time(t _{s min} to t _{s max})	60-120 seconds	60-180 seconds
Time maintained above:		
-Temperature (T _L)	183°C	217°C
- Time (t _L)	60-150 seconds	60-150 seconds
Peak Temperature(T _P)	240 +0/-5 °C	260 +0/-5 °C
Time within 5°C of actual peak temperature(tp)	10-30 seconds	20-40 seconds
Ramp down rate	6°C/second max.	6°C/second max.
Time 25 °C to peak temperature	6 minutes max.	8 minutes max.

Note : All temperatures refer to topside of the package, measured on the package body surface.

SOT-223 Dimension

Marking:

Vout:
 1.5V→-15
 1.8V→-18
 2.5V→-25
 3.3V→-33
 5.0V→-50
 ADJ→blank

Device Name
 Date Code : (from left to right)
 1st code : year code, 1→2011, 2→2012, ...,etc.
 2nd code : month code, referring to the following table
 3rd and 4th codes : production lot serial number , 01, 02, 03, ... etc

Style: Pin 1.Adj/Gnd 2.Output 3.Input

3-Lead SOT-223 Plastic Surface Mounted Package
 CYStek Package Code: L3

Month code :

Month	Jan	Feb	Mar	Apr	May	Jun	Jul	Aug	Sep	Oct	Nov	Dec
Code	A	B	C	D	E	F	G	H	J	K	L	M

*: Typical

DIM	Inches		Millimeters		DIM	Inches		Millimeters	
	Min.	Max.	Min.	Max.		Min.	Max.	Min.	Max.
A	0.1142	0.1220	2.90	3.10	G	0.0551	0.0709	1.40	1.80
B	0.2638	0.2874	6.70	7.30	H	0.0098	0.0138	0.25	0.35
C	0.1299	0.1457	3.30	3.70	I	0.0008	0.0039	0.02	0.10
D	0.0236	0.0315	0.60	0.80	a1	*13°	-	*13°	-
E	*0.0906	-	*2.30	-	a2	0°	10°	0°	10°
F	0.2480	0.2638	6.30	6.70					

Notes: 1.Controlling dimension: millimeters.
 2.Maximum lead thickness includes lead finish thickness, and minimum lead thickness is the minimum thickness of base material.
 3.If there is any question with packing specification or packing method, please contact your local CYStek sales office.

Material:

- Lead: Pure tin plated.
- Mold Compound: Epoxy resin family, flammability solid burning class: UL94V-0.

Important Notice:

- All rights are reserved. Reproduction in whole or in part is prohibited without the prior written approval of CYStek.
- CYStek reserves the right to make changes to its products without notice.
- CYStek **semiconductor products are not warranted to be suitable for use in Life-Support Applications, or systems.**
- CYStek assumes no liability for any consequence of customer product design, infringement of patents, or application assistance.