



Super Fast Surface Mount Rectifiers
Reverse Voltage 50V to 1000V Forward Current 2.0A

ES2A thru ES2J

Features

- For surface mounted application
- Low profile package
- Built-in stain relief, ideal for automatic placement
- Easy pick and place
- Super fast recovery time for high efficiency
- Glass passivated junction chip
- High temperature soldering: 250° C/10 seconds at terminals
- Plastic material used carries UL flammability classification 94V-0

Outline

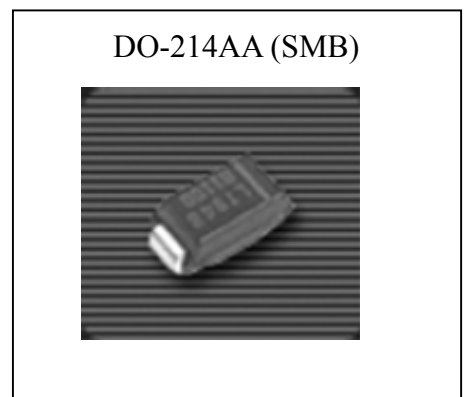

Mechanical Data

- Case: SMB/DO-214AA molded plastic
- Terminals: Pure tin plated, solderable per MIL-STD-750 method 2026
- Polarity: Indicated by cathode band
- Weight: 0.093 gram approx.

Ordering Information

Device	Package	Shipping
ES2X - 0-T6-G	SMB (Pb-free lead plating and halogen-free package)	3000 pcs / Tape & Reel

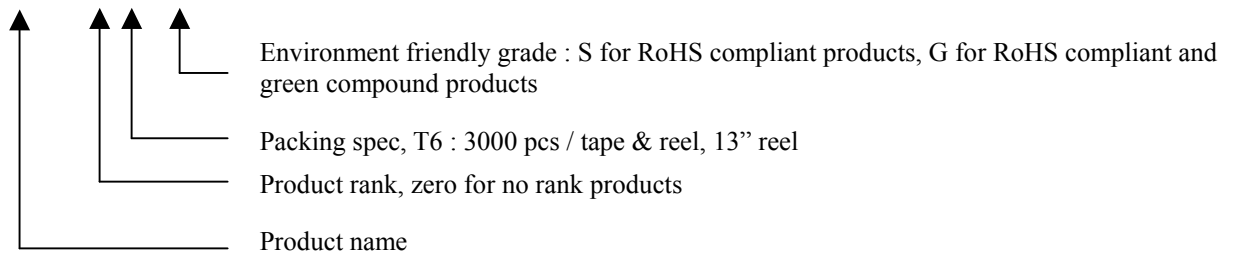



Maximum Ratings and Electrical Characteristics

(Rating at 25°C ambient temperature unless otherwise specified. Single phase, half wave, 60Hz, resistive or inductive load. For capacitive load, derate current by 20%.)

Parameter	Symbol	Type								Units
		ES2A	ES2B	ES2C	ES2D	ES2F	ES2G	ES2H	ES2J	
Maximum repetitive peak reverse voltage	V _{RRM}	50	100	150	200	300	400	500	600	V
Maximum RMS voltage	V _{RMS}	35	70	105	140	210	280	350	420	V
Maximum DC blocking voltage	V _R	50	100	150	200	300	400	500	600	V
Maximum instantaneous forward voltage, I _F =2A	V _F	0.95			1.3		1.7			V
Maximum average forward rectified current, see Fig. 1	I _{F(AV)}	2								A
Peak forward surge current @8.3ms single half sine wave superimposed on rated load (JEDEC method)	I _{FSM}	50								A
Maximum DC reverse current V _R =V _{RRM} , T _A =25°C V _R =V _{RRM} , T _A =100°C	I _R	10 500								μA
Maximum reverse recovery time (Note 1)	t _{rr}	35								ns
Typical thermal resistance	R _{θJA} R _{θJC}	75 (Note 2) 18								°C/W
Power dissipation	T _A =25°C	1.7 (Note 2)								W
	T _C =25°C	7								
Storage temperature range	T _{STG}	-55 ~ +150								°C
Operating junction temperature range	T _J	-55 ~ +150								°C

Note: 1.Reverse recovery test conditions : I_F=0.5A, I_R=1A, I_{RR}=0.25A
 2.P.C.B. mounted on 0.4"×0.4"(10mm×10mm) copper pad area.

Typical Characteristics

FIG.1- MAXIMUM FORWARD CURRENT DERATING CURVE

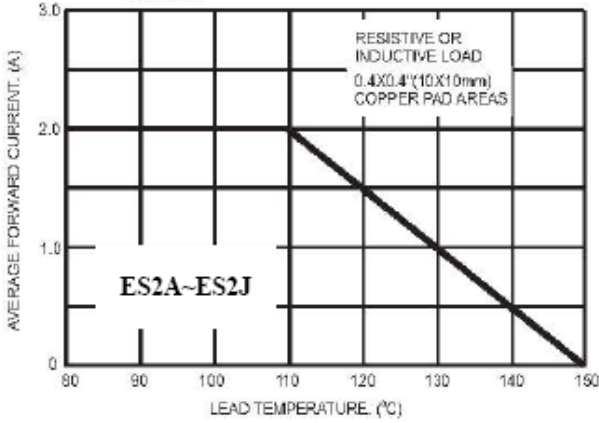

FIG.2- MAXIMUM NON-REPETITIVE PEAK FORWARD SURGE CURRENT

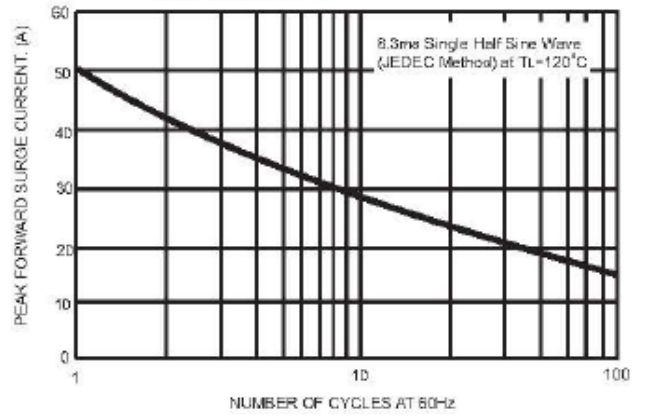

FIG.3- TYPICAL INSTANTANEOUS FORWARD CHARACTERISTICS

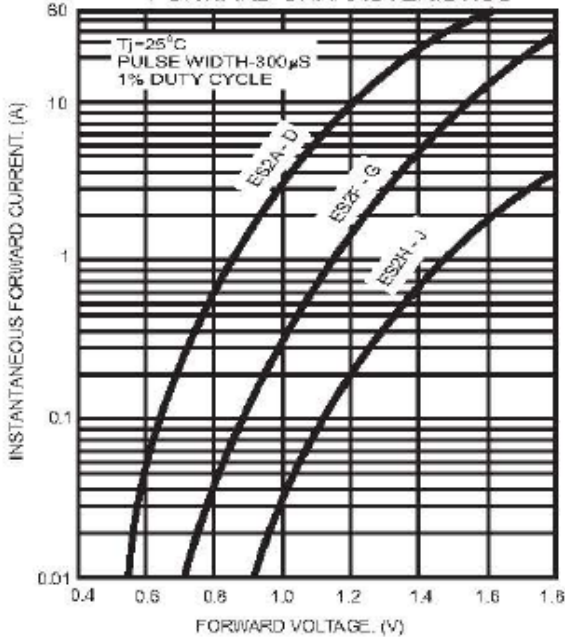
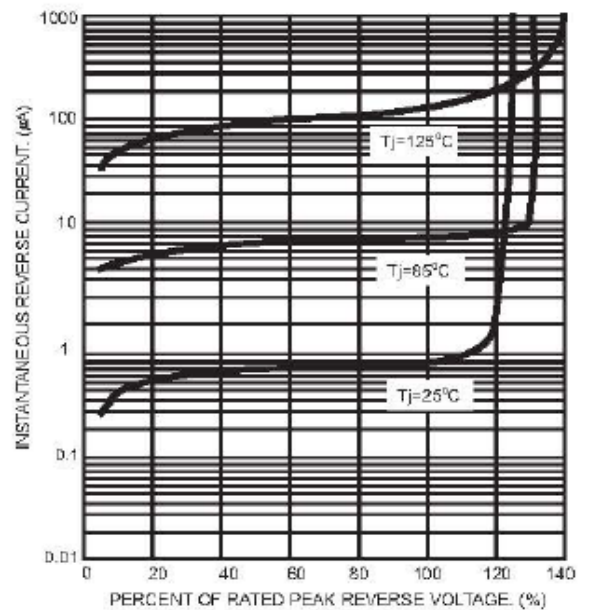
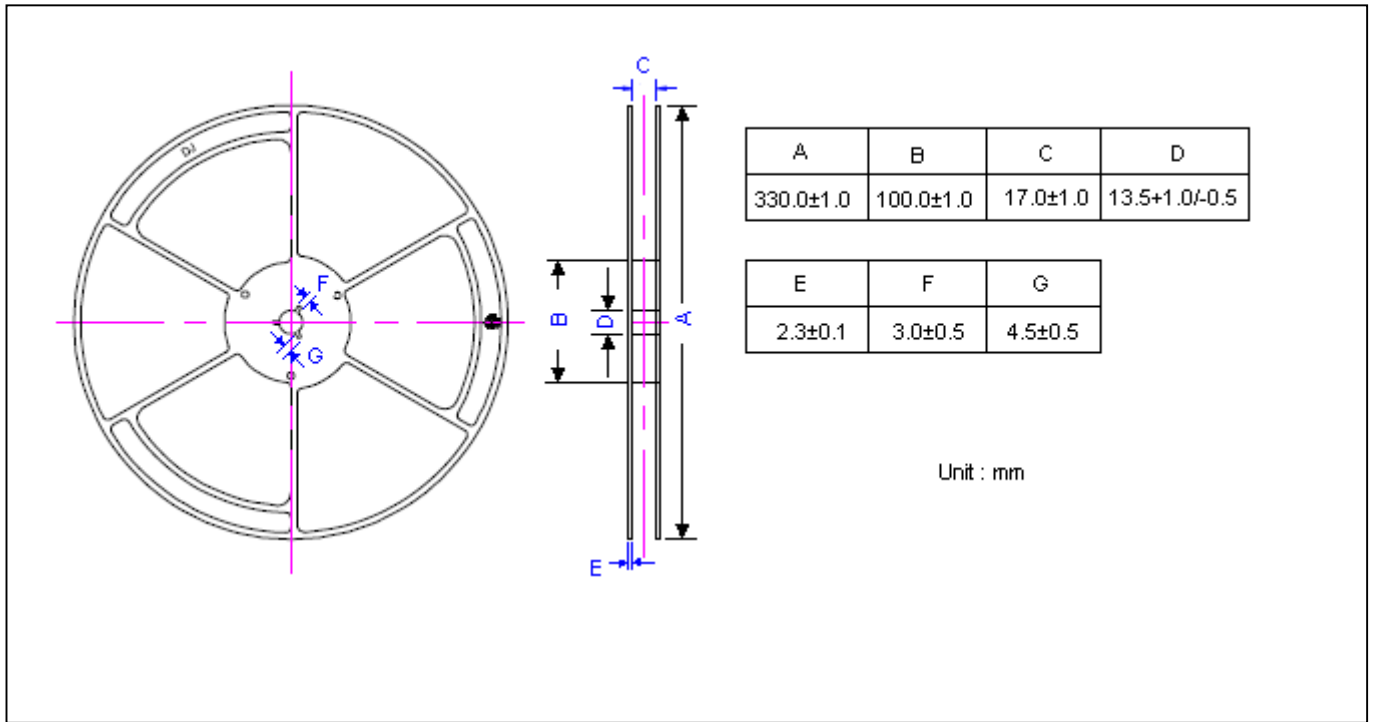

FIG.4- TYPICAL REVERSE CHARACTERISTICS



Reel Dimension



Carrier Tape Dimension

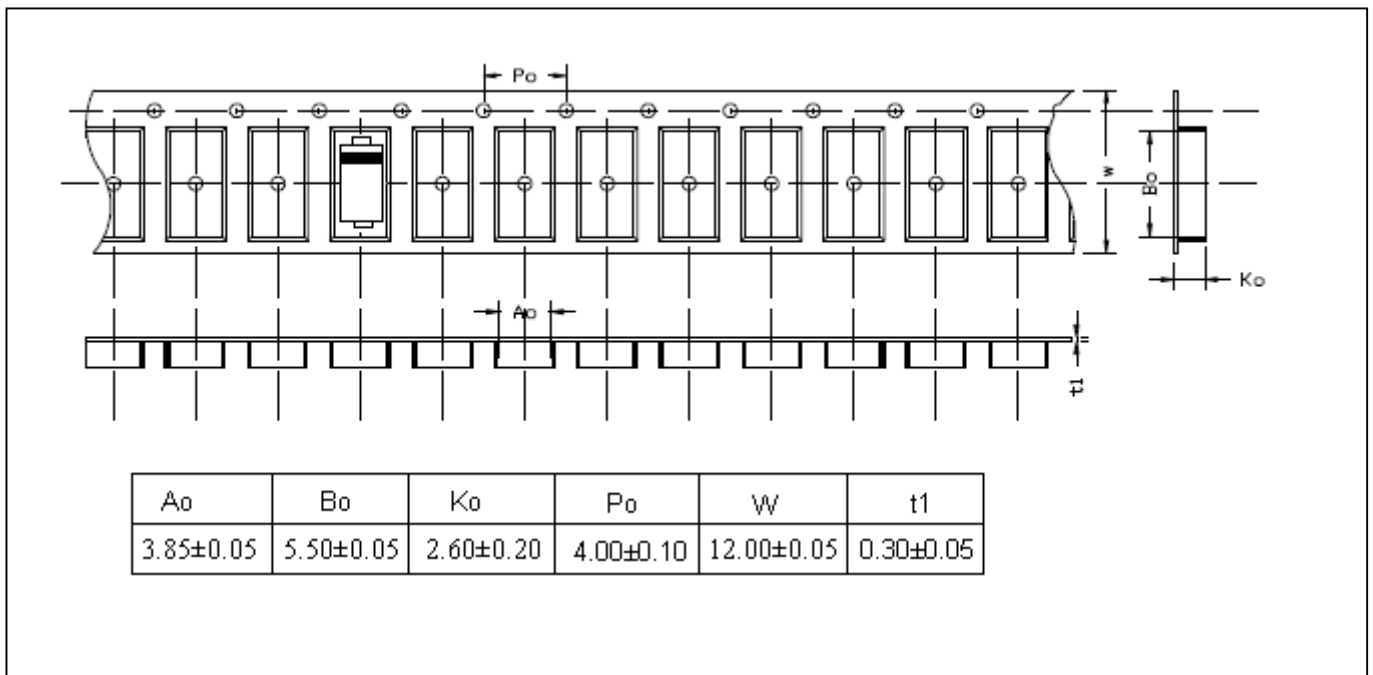

Recommended Footprint

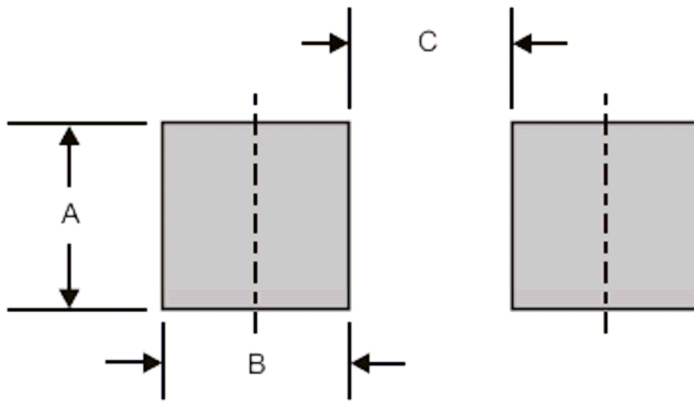

Dimensions in inches and (millimeters)

DIM	Inches	Millimeters
	Typ	Typ
A	0.142	3.60
B	0.059	1.50
C	0.118	3.00

Recommended wave soldering condition

Product	Peak Temperature	Soldering Time
Pb-free devices	260 +0/-5 °C	5 +1/-1 seconds

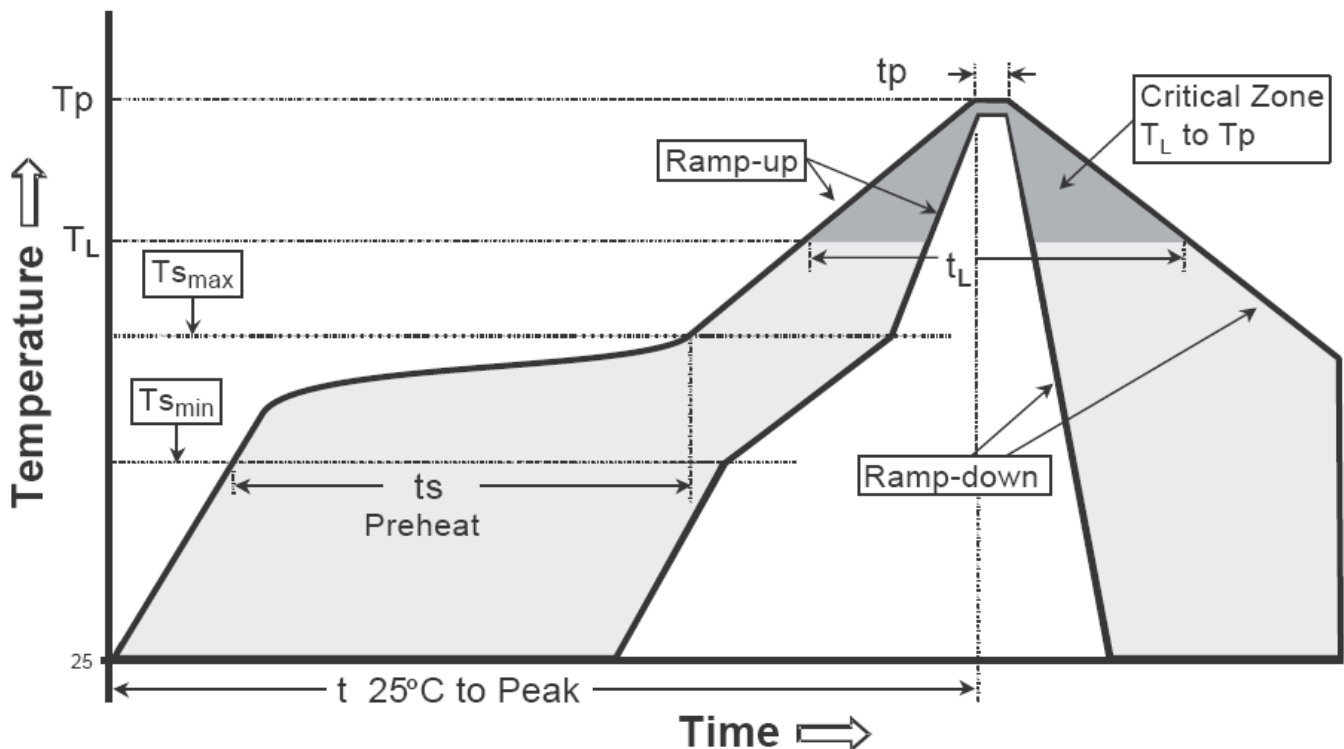
Recommended temperature profile for IR reflow

Profile feature	Sn-Pb eutectic Assembly	Pb-free Assembly
Average ramp-up rate (T _{smax} to T _p)	3°C/second max.	3°C/second max.
Preheat		
-Temperature Min(T _{s min})	100°C	150°C
-Temperature Max(T _{s max})	150°C	200°C
-Time(t _{s min} to t _{s max})	60-120 seconds	60-180 seconds
Time maintained above:		
-Temperature (T _L)	183°C	217°C
- Time (t _L)	60-150 seconds	60-150 seconds
Peak Temperature(T _P)	240 +0/-5 °C	260 +0/-5 °C
Time within 5°C of actual peak temperature(tp)	10-30 seconds	20-40 seconds
Ramp down rate	6°C/second max.	6°C/second max.
Time 25 °C to peak temperature	6 minutes max.	8 minutes max.

Note : All temperatures refer to topside of the package, measured on the package body surface.

SMB/DO-214AA Dimension

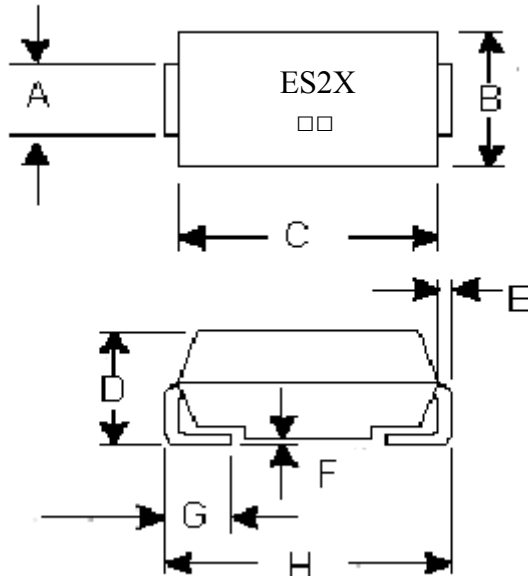

SMB/DO-214AA Plastic
 Surface Mounted Package
 CYStek Package Code : SB

Marking Code :

Device Code + Date Code

Device	ES2A	ES2B	ES2C	ES2D
Code	ES2A	ES2B	ES2C	ES2D

Device	ES2F	ES2G	ES2H	ES2J
Code	ES2F	ES2G	ES2H	ES2J

Date Code : Year + Month code

Year Code :

2009	2010	2011	2012	2013	2014	2015
9	A	B	C	D	E	F
2016	2017	2018	2019	2020	2021	2022
G	H	J	K	0	1	2

Month Code:

Jan	Feb	Mar	Apr	May	Jun
1	2	3	4	5	6
Jul	Aug	Sep	Oct	Nov	Dec
7	8	9	O	N	D

*:Typical

DIM	Inches		Millimeters		DIM	Inches		Millimeters	
	Min.	Max.	Min.	Max.		Min.	Max.	Min.	Max.
A	0.075	0.083	1.91	2.11	E	0.006	0.012	0.152	0.305
B	0.130	0.155	3.30	3.94	F	0.002	0.008	0.051	0.203
C	0.160	0.185	4.06	4.70	G	0.030	0.060	0.76	1.52
D	0.083	0.096	2.13	2.44	H	0.200	0.220	5.08	5.59

- Notes : 1. Controlling dimension : millimeters.
 2. Maximum lead thickness includes lead finish thickness, and minimum lead thickness is the minimum thickness of base material.
 3. If there is any question with packing specification or packing method, please contact your local CYStek sales office.

Material :

- Lead : Pure tin plated.
- Mold Compound : Epoxy resin family, flammability solid burning class:UL94V-0.

Important Notice:

- All rights are reserved. Reproduction in whole or in part is prohibited without the prior written approval of CYStek.
- CYStek reserves the right to make changes to its products without notice.
- CYStek **semiconductor products are not warranted to be suitable for use in Life-Support Applications, or systems.**
- CYStek assumes no liability for any consequence of customer product design, infringement of patents, or application assistance.