

Small Signal Schottky (double) diodes

BAT54N3/BAT54AN3

BAT54CN3/BAT54SN3

Description

Planar silicon Schottky barrier diodes encapsulated in a SOT-23 small plastic SMD package. Single diodes and double diodes with different pinning are available.

Features

- Very small conduction losses
- Low forward voltage drop
- Small plastic SMD package
- Pb-free lead-free and halogen-free package

Applications

- Ultra high-speed switching
- Voltage clamping
- Protection circuits
- Blocking diodes

Pinning

Pin	Description			
	BAT54	BAT54A	BAT54C	BAT54S
1	A	K1	A1	A1
2	NC	K2	A2	K2
3	K	A1,A2	K1,K2	K1,A1

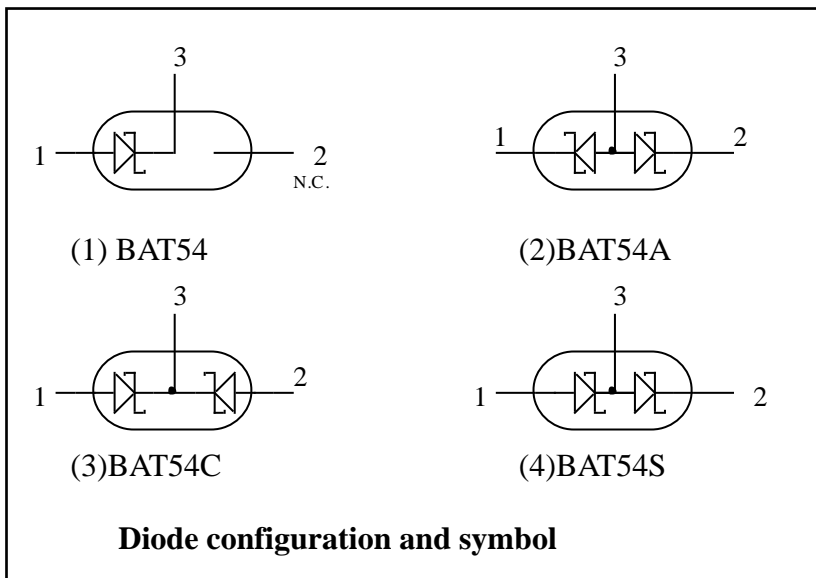

Outline

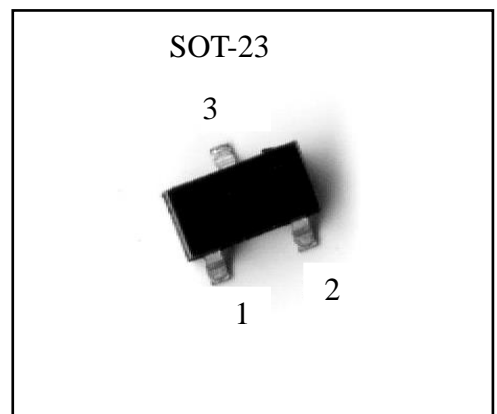

Marking:

Type	Marking Code
BAT54 N3	JV3
BAT54AN3	B6
BAT54CN3	5C
BAT54SN3	LD3



Absolute Maximum Ratings

- Maximum Temperatures
 - Storage Temperature Tstg..... -65 ~ +150 °C
 - Operating Junction Temperature Tj -65 ~ +150°C
- Maximum Power Dissipation
 - Total Power Dissipation (Ta=25°C) Ptot (Note) 230 mW
- Maximum Voltages and Currents (Ta=25°C)
 - Repetitive Peak Reverse Voltage VRRM..... 30 V
 - Continuous Forward Current IF 200 mA
 - Repetitive Peak Forward Current(tp≤1s,duty cycle≤0.5)..... 300mA
 - Non-repetitive Peak Forward Current (tp<10ms, sinusoidal) IFSM..... 600 mA

Note : For double diodes, Ptot is the total power dissipation of both diodes.

Thermal Performance

Parameter	Symbol	Limit	Unit
Thermal Resistance, Junction-to-Ambient, max	RθJA	435	°C/W
Thermal Resistance, Junction-to-Case, max	RθJC	270	

Characteristics (Ta=25°C)

Characteristic	Symbol	Condition	Min.	Max.	Unit
Reverse Breakdown Voltage	VBR	IR=100µA	30	-	V
Forward Voltage (Note 1)	VF(1)	IF=0.1mA	-	240	mV
	VF(2)	IF=1mA	-	320	mV
	VF(3)	IF=10mA	-	400	mV
	VF(4)	IF=30mA	-	500	mV
	VF(5)	IF=100mA	-	800	mV
Reverse Leakage Current (Note 2)	IR	VR=25V,Tj=25°C	-	2	µA
Diode Capacitance	CD	VR=1V, f=1MHz	-	10	pF
Reverse Recovery Time	trr	IF=IR=10mA RL=100Ω measured at IR=1mA	-	5	ns

Notes: 1.pulse test, tp=380µs,duty cycle<2%.
 2.pulse test, tp=5ms,duty cycle<2%.

Ordering Information

Device	Package	Shipping	Marking
BAT54N3-0-T1-G	SOT-23 (Pb-free lead plating and halogen-free package)	3000 pcs / Tape & Reel	JV3
BAT54AN3-0-T1-G			B6
BAT54CN3-0-T1-G			5C
BAT54SN3-0-T1-G			LD3

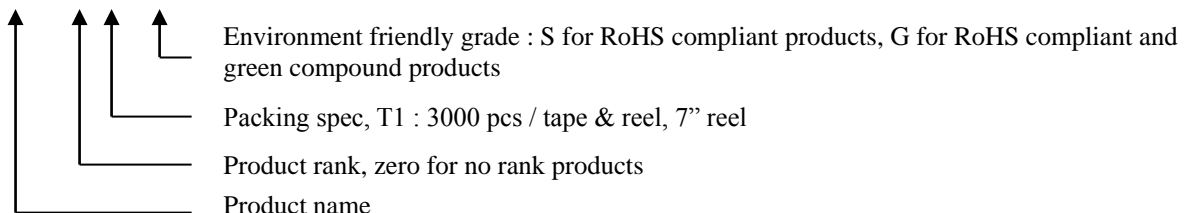

Typical Characteristics

Forward Current vs Forward Voltage

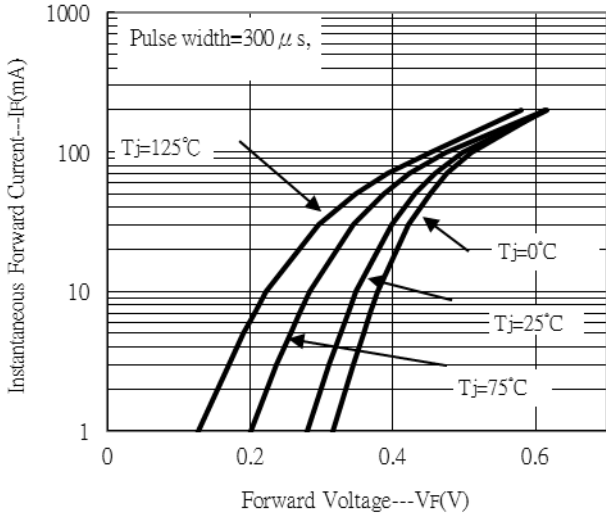

Reverse Leakage Current vs Reverse Voltage

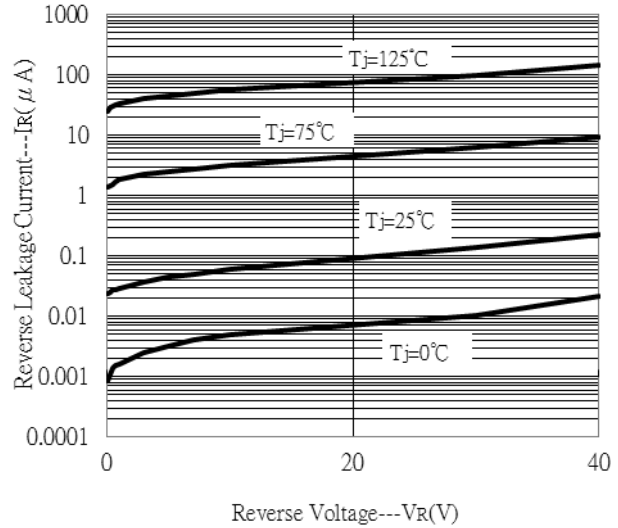

Junction Capacitance vs Reverse Voltage

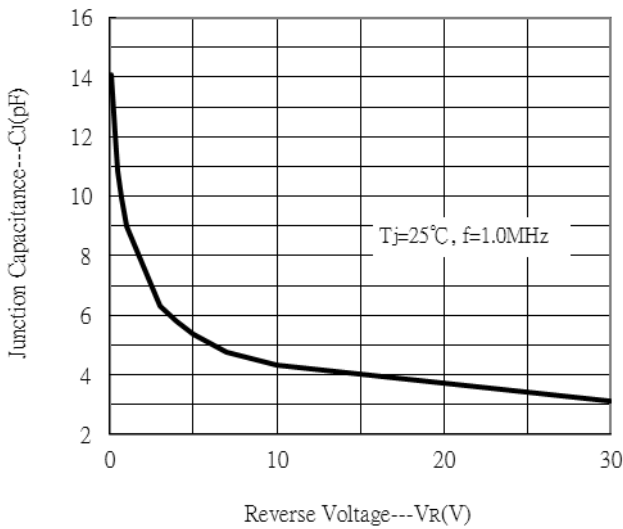

Recommended Soldering Footprint

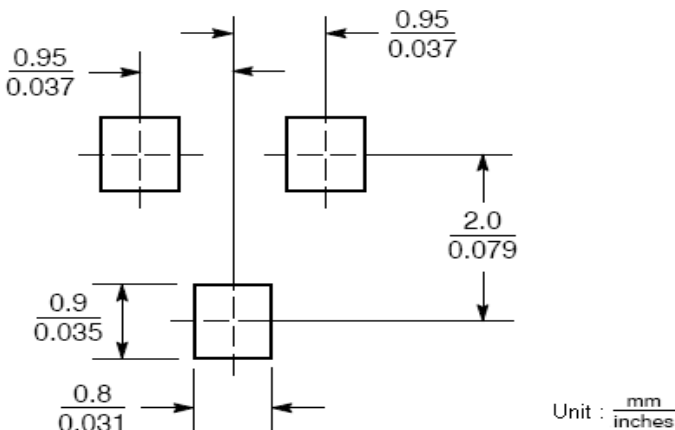

Recommended wave soldering condition

Product	Peak Temperature	Soldering Time
Pb-free devices	260 +0/-5 °C	5 +1/-1 seconds

Recommended temperature profile for IR reflow

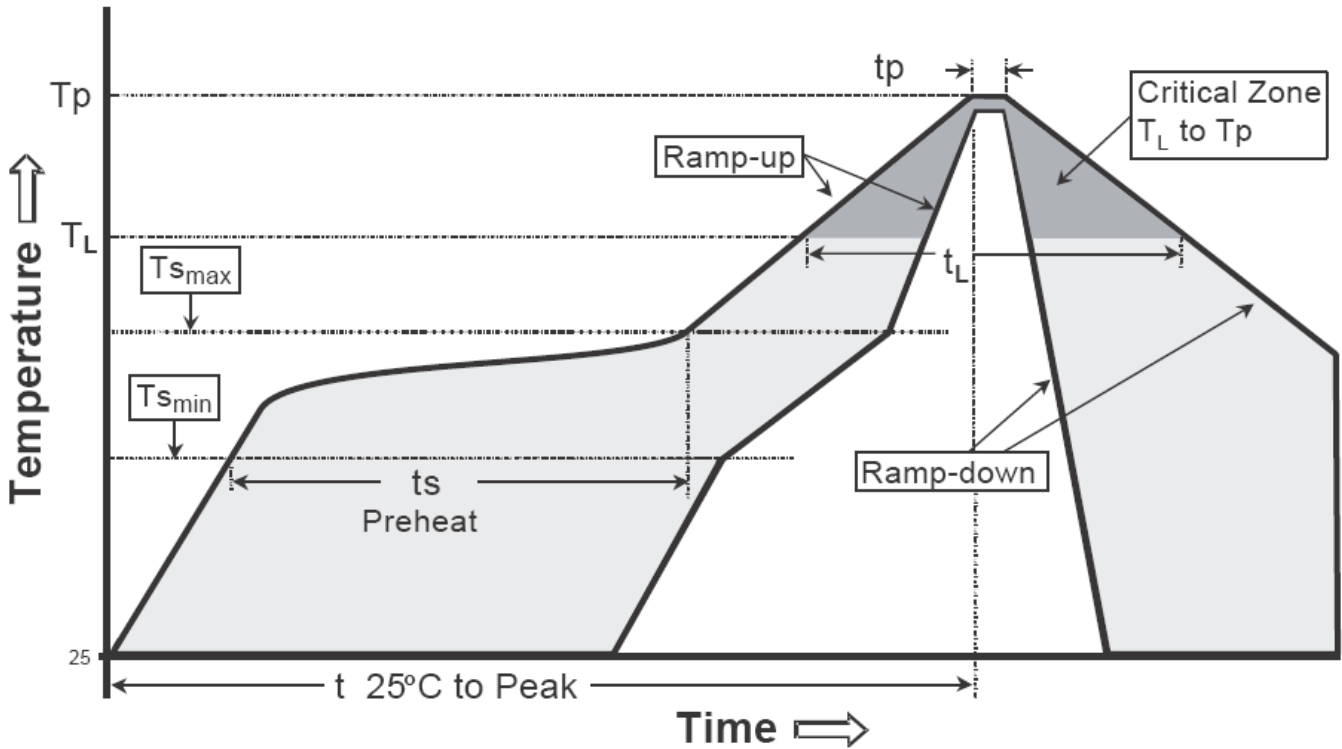

Profile feature	Sn-Pb eutectic Assembly	Pb-free Assembly
Average ramp-up rate (Tsmax to Tp)	3°C/second max.	3°C/second max.
Preheat		
-Temperature Min(Ts min)	100°C	150°C
-Temperature Max(Ts max)	150°C	200°C
-Time(ts min to ts max)	60-120 seconds	60-180 seconds
Time maintained above:		
-Temperature (T _L)	183°C	217°C
- Time (t _L)	60-150 seconds	60-150 seconds
Peak Temperature(T _P)	240 +0/-5 °C	260 +0/-5 °C
Time within 5°C of actual peak temperature(tp)	10-30 seconds	20-40 seconds
Ramp down rate	6°C/second max.	6°C/second max.
Time 25 °C to peak temperature	6 minutes max.	8 minutes max.

Note : All temperatures refer to topside of the package, measured on the package body surface.

Reel Dimension

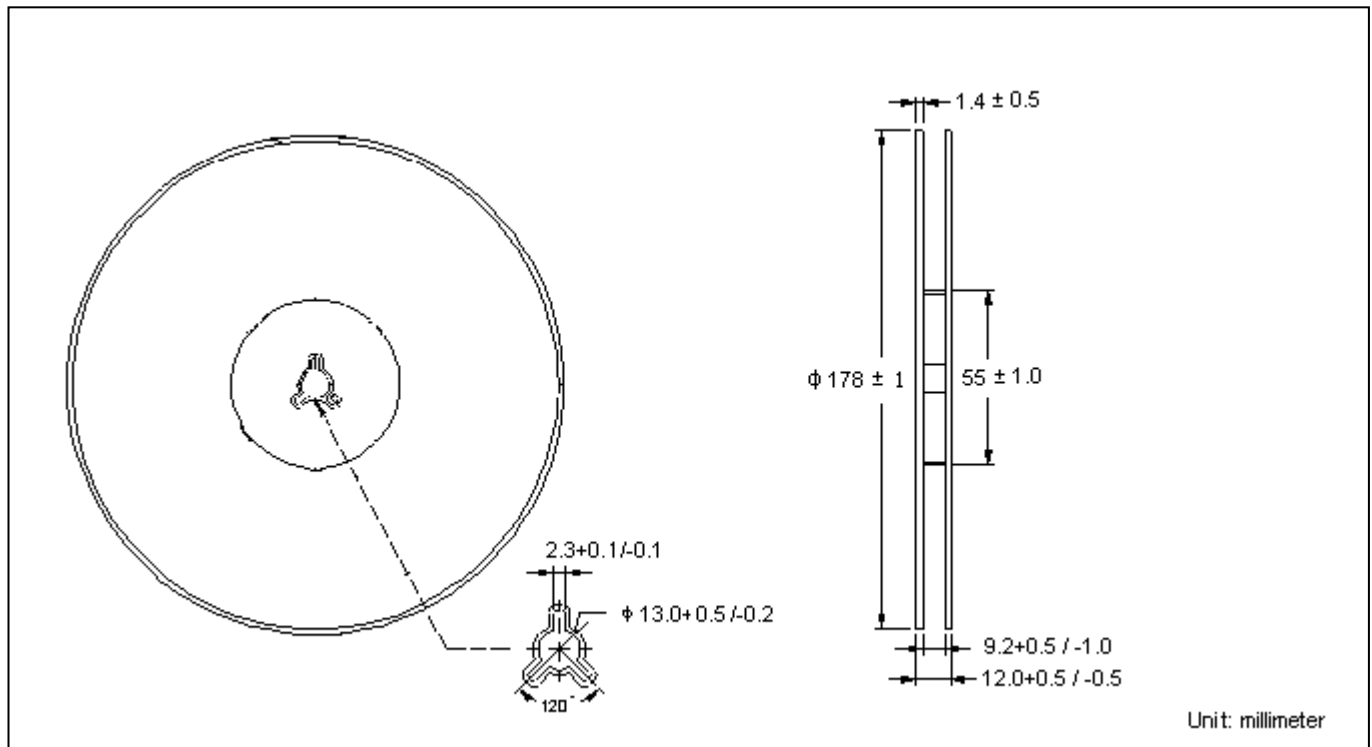

Carrier Tape Dimension

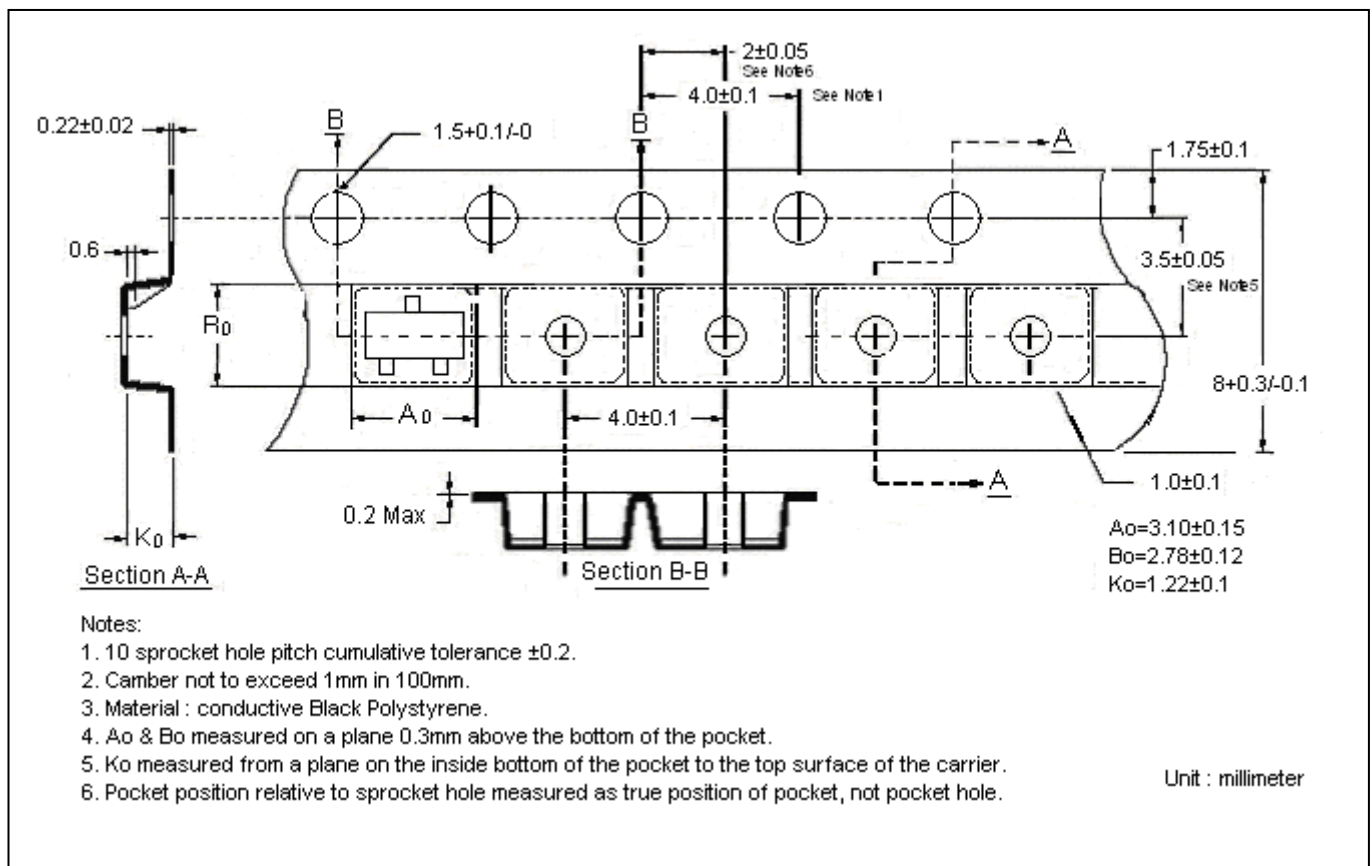

SOT-23 Dimension

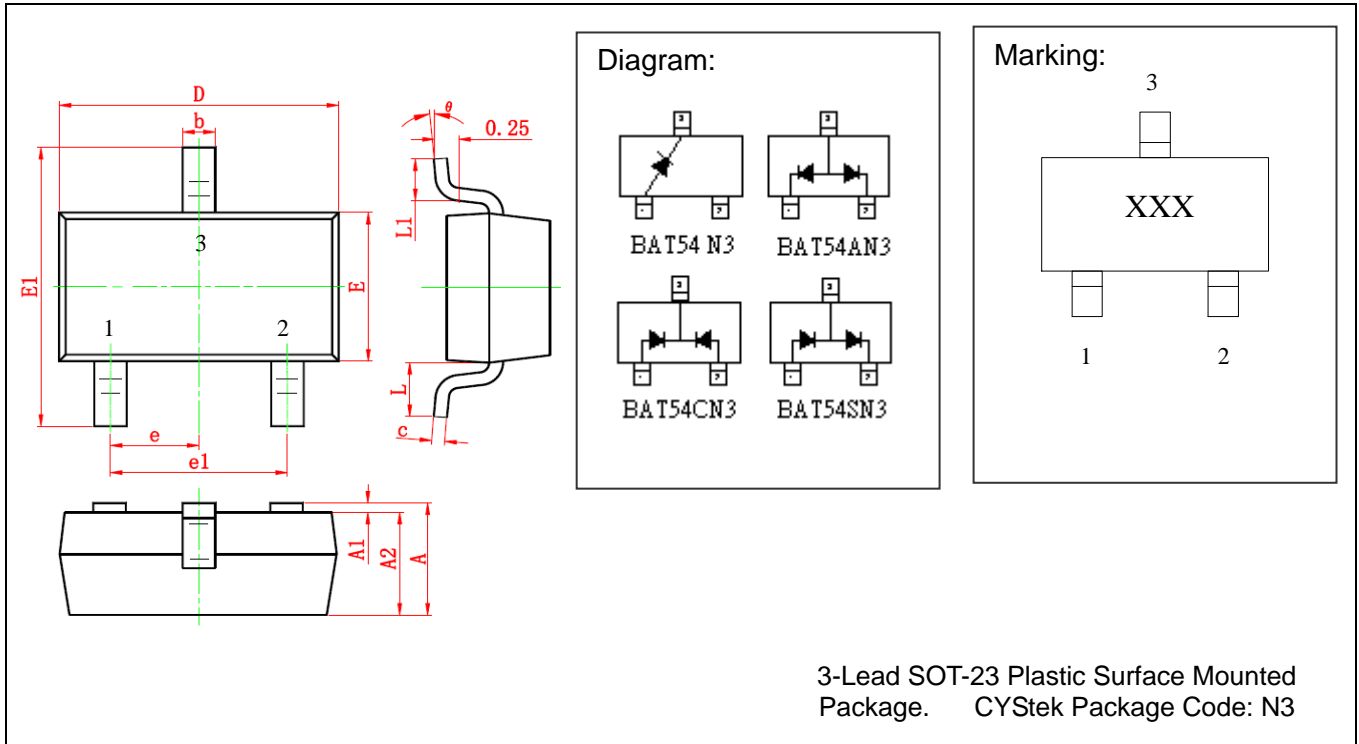

The diagram shows the mechanical dimensions of a 3-lead SOT-23 package. It includes a top view with dimensions D, b, E, E1, e, e1, and L. A side view shows dimensions A, A1, A2, L, L1, and a lead thickness of 0.25. A perspective view shows dimensions A1, A2, and A. The 'Diagram' section shows four circuit symbols: BAT54 N3 (single diode), BAT54AN3 (common anode), BAT54CN3 (common cathode), and BAT54SN3 (series connected). The 'Marking' section shows a rectangular package with 'XXX' in the center and leads labeled 1, 2, and 3.

3-Lead SOT-23 Plastic Surface Mounted Package. CYStek Package Code: N3

- BAT54 N3: Single Diode (Marking Code JV3)
- BAT54AN3: Common Anode. (Marking Code B6)
- BAT54CN3: Common Cathode. (Marking Code 5C)
- BAT54SN3: Series Connected. (Marking Code LD3)

*: Typical

DIM	Millimeters		Inches		DIM	Millimeters		Inches	
	Min.	Max.	Min.	Max.		Min.	Max.	Min.	Max.
A	0.900	1.150	0.035	0.045	E1	2.250	2.550	0.089	0.100
A1	0.000	0.100	0.000	0.004	e	0.950	TYP	0.037	TYP
A2	0.900	1.050	0.035	0.041	e1	1.800	2.000	0.071	0.079
b	0.300	0.500	0.012	0.020	L	0.550	REF	0.022	REF
c	0.080	0.150	0.003	0.006	L1	0.300	0.500	0.012	0.020
D	2.800	3.000	0.110	0.118	θ	0°	8°	0°	8°
E	1.200	1.400	0.047	0.055					

Notes: 1. Controlling dimension: millimeters.
 2. Maximum lead thickness includes lead finish thickness, and minimum lead thickness is the minimum thickness of base material.
 3. If there is any question with packing specification or packing method, please contact your local CYStek sales office.

Material:

- Lead: Pure tin plated.
- Mold Compound: Epoxy resin family, flammability solid burning class: UL94V-0.

Important Notice:

- All rights are reserved. Reproduction in whole or in part is prohibited without the prior written approval of CYStek.
- CYStek reserves the right to make changes to its products without notice.
- CYStek **semiconductor products are not warranted to be suitable for use in Life-Support Applications, or systems.**
- CYStek assumes no liability for any consequence of customer product design, infringement of patents, or application assistance.