

Small Signal Schottky (double) diodes

BAT54S3/BAT54AS3

BAT54CS3/BAT54SS3

Description

Planar silicon Schottky barrier diodes encapsulated in a SOT-323 very small plastic SMD package. Single diodes and double diodes with different pinning are available.

Features

- Guard ring protected
- Low forward voltage drop
- Very small plastic SMD package
- Pb-free lead plating and halogen-free package

Applications

- Ultra high-speed switching
- Voltage clamping
- Protection circuits
- Blocking diodes

Pinning

Pin	Description			
	BAT54	BAT54A	BAT54C	BAT54S
1	A	K1	A1	A1
2	NC	K2	A2	K2
3	K	A1,A2	K1,K2	K1,A1

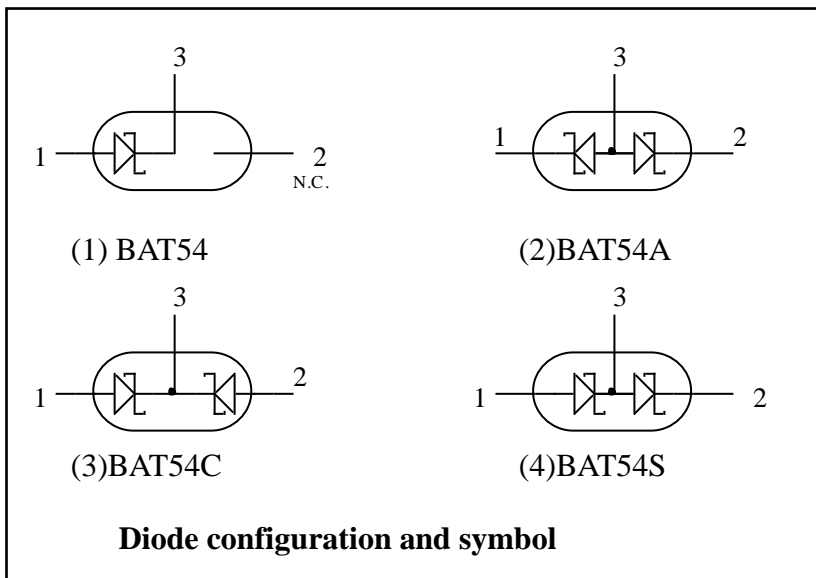

Outline

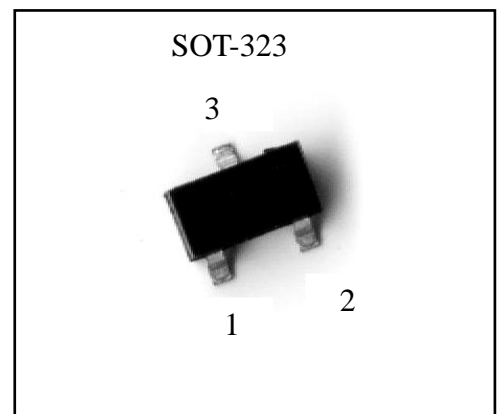

Marking:

Type	Marking Code
BAT54 S3	B4
BAT54AS3	B7
BAT54CS3	5C
BAT54SS3	B8

**Absolute Maximum Ratings**

Symbol	Parameter	Conditions	Min	Max	Unit
Per diode					
V _R	continuous reverse voltage		-	30	V
I _F	continuous forward current		-	200	mA
I _{FRM}	repetitive peak forward current	tp≤1s, δ≤0.5	-	300	mA
I _{FSM}	non-repetitive peak forward current	tp<10ms	-	600	mA
P _{tot}	total power dissipation (per package)	T _{amb} ≤25°C	-	200	mW
T _{stg}	storage temperature		-65	+150	°C
T _j	operating junction temperature		-65	+150	°C
T _{amb}	operating ambient temperature		-65	+125	°C

Characteristics (T_a=25°C, unless otherwise specified)

Parameter	Symbol	Condition	Min.	Max.	Unit
Reverse Breakdown Voltage	V _{BR}	I _R =100μA	30	-	V
Forward Voltage (Note 1)	V _F (1)	I _F =0.1mA	-	240	mV
	V _F (2)	I _F =1mA	-	320	mV
	V _F (3)	I _F =10mA	-	400	mV
	V _F (4)	I _F =30mA	-	500	mV
	V _F (5)	I _F =100mA	-	800	mV
Reverse Leakage Current (Note 2)	I _R	V _R =25V	-	2	μA
Diode Capacitance	C _D	V _R =1V, f=1MHz	-	10	pF
Reverse Recovery Time	t _{rr}	when switched from I _F = 10mA to I _R =10mA; R _L =100Ω; measured at I _R =1mA	-	5	ns

Notes: 1.pulse test, tp=380μs, duty cycle<2%.

2.pulse test, tp=300μs, duty cycle<2%.

Thermal Characteristics

Symbol	Parameter	Conditions	Value	Unit
R _{th j-a}	thermal resistance from junction to ambient	note 1	625	K/W

Note 1 : Refer to SOT-323 standard mounting conditions.



Ordering Information

Device	Package	Shipping	Marking
BAT54S3-0-T1-G	SOT-323 (Pb-free lead plating and halogen-free package)	3000 pcs / Tape & Reel	B4
BAT54AS3-0-T1-G			B7
BAT54CS3-0-T1-G			5C
BAT540SS3-0-T1-G			B8

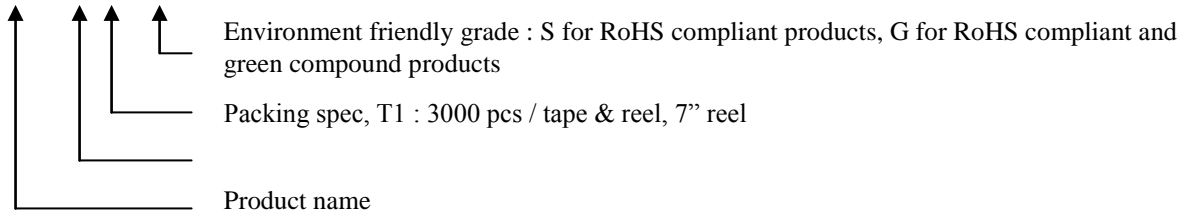

Typical Characteristics

Forward Current vs Forward Voltage

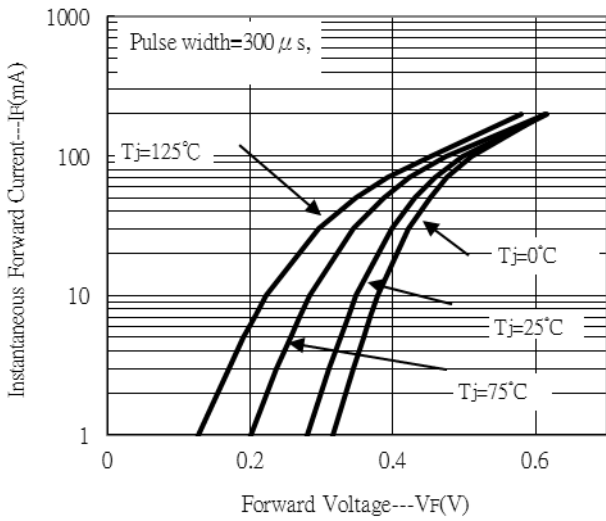

Reverse Leakage Current vs Reverse Voltage

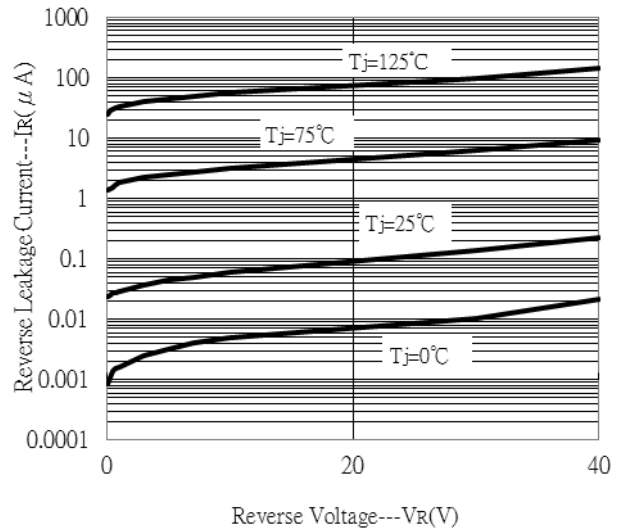

Junction Capacitance vs Reverse Voltage

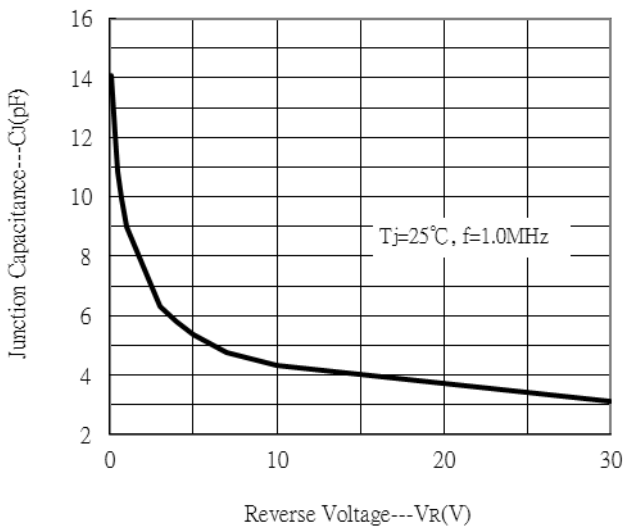

Recommended Footprint

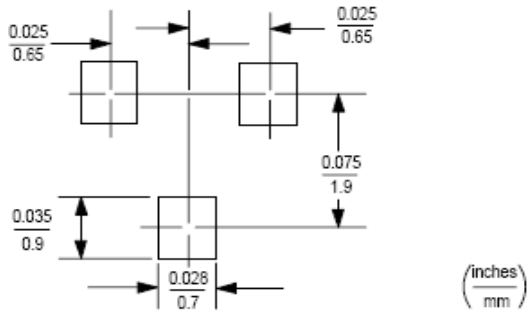

Reel Dimension

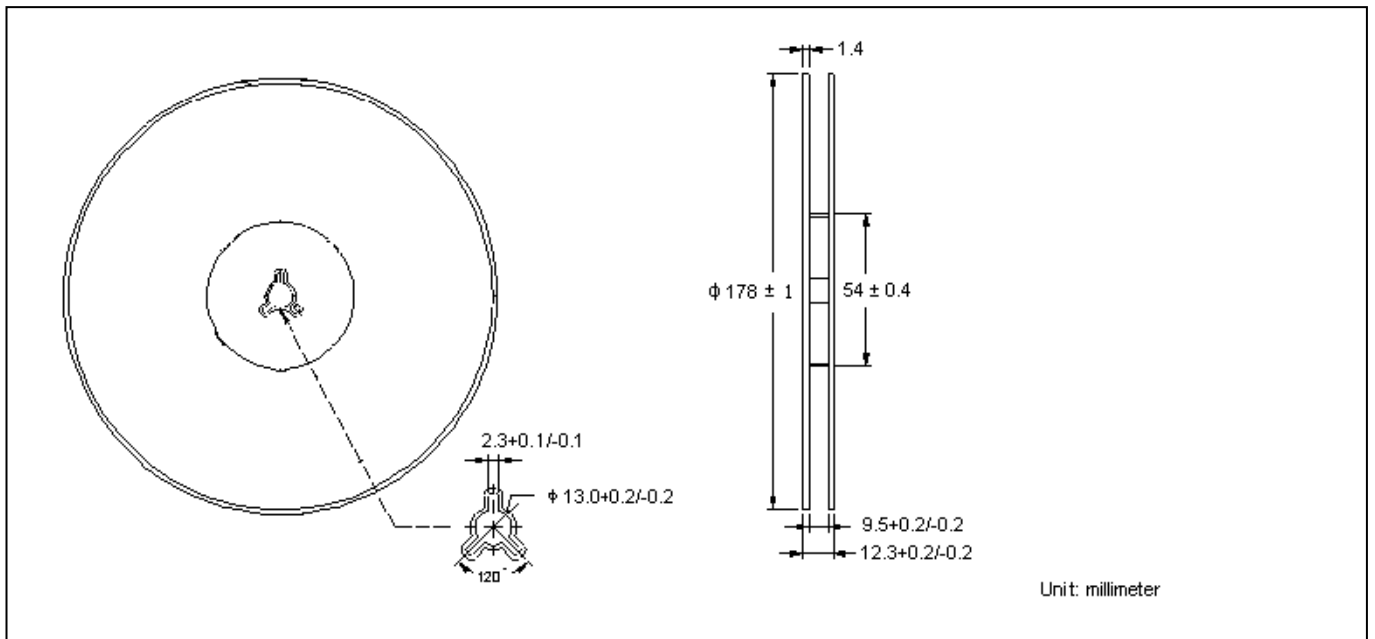

Carrier Tape Dimension

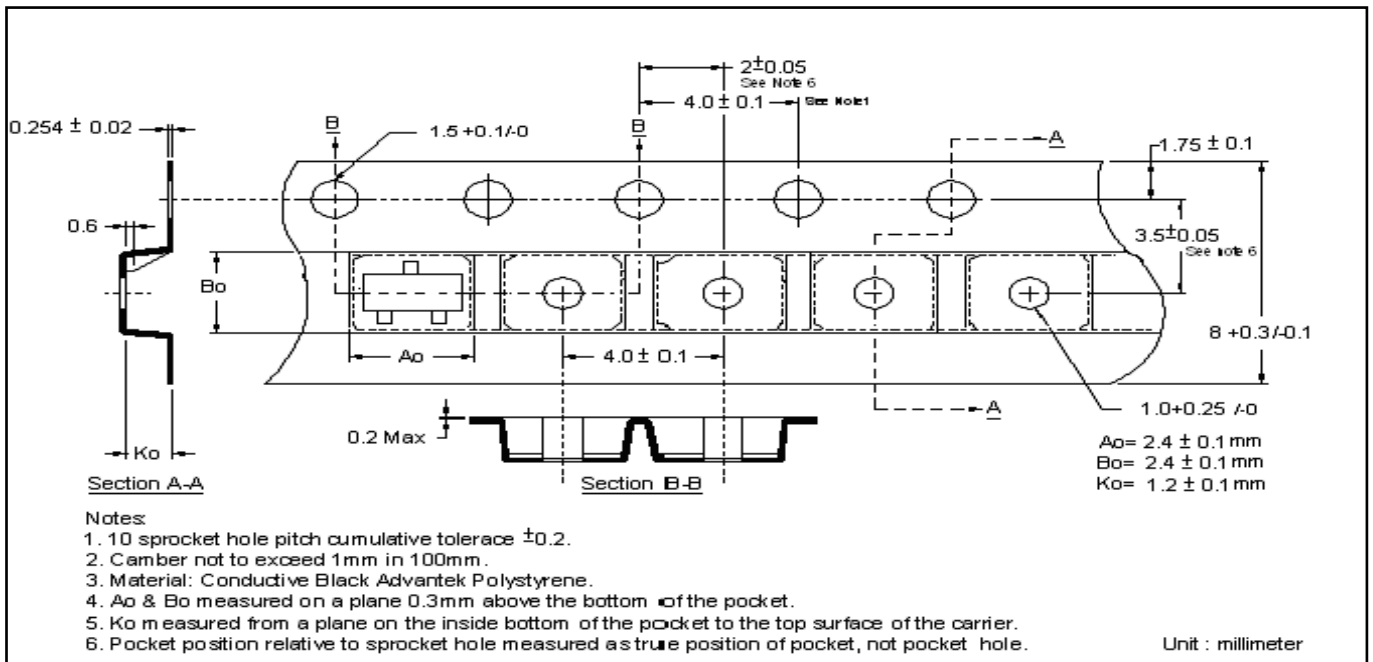

Recommended wave soldering condition

Product	Peak Temperature	Soldering Time
Pb-free devices	260 +0/-5 °C	5 +1/-1 seconds

Recommended temperature profile for IR reflow

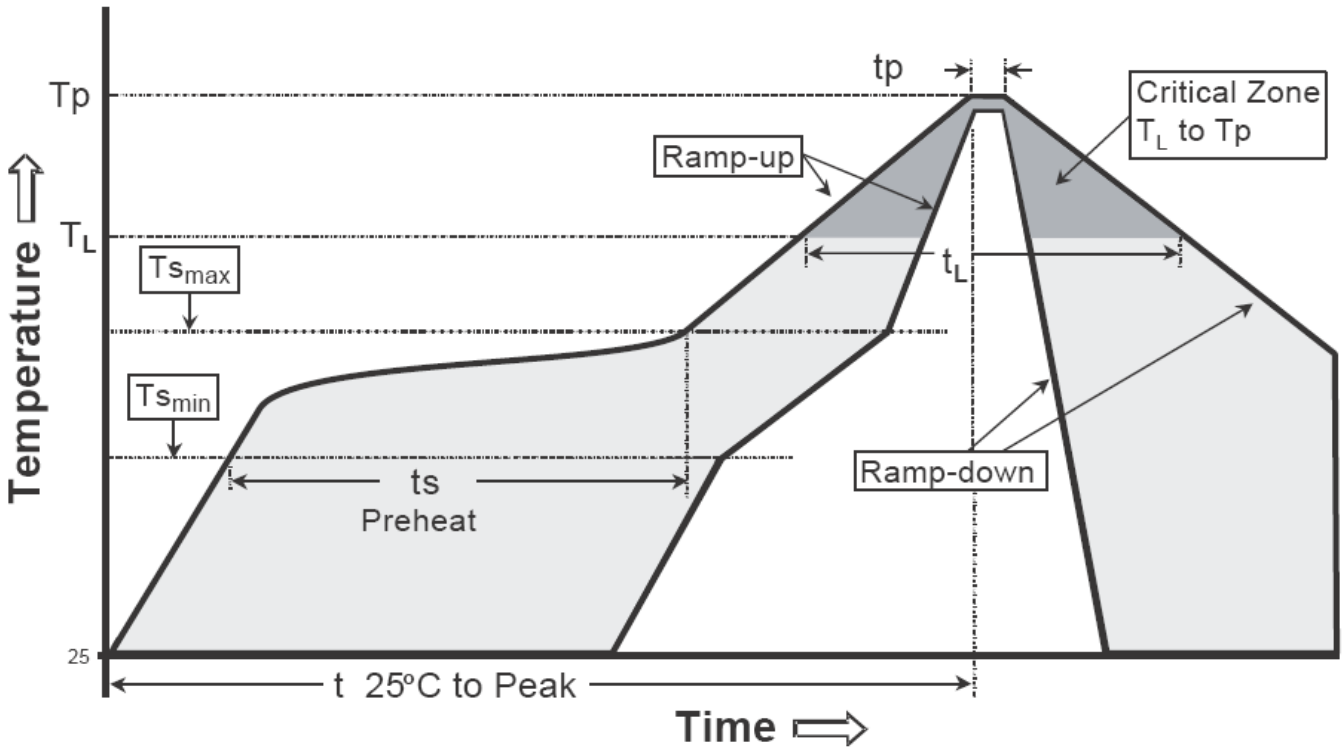

Profile feature	Sn-Pb eutectic Assembly	Pb-free Assembly
Average ramp-up rate (Tsmax to Tp)	3°C/second max.	3°C/second max.
Preheat		
-Temperature Min(Ts min)	100°C	150°C
-Temperature Max(Ts max)	150°C	200°C
-Time(ts min to ts max)	60-120 seconds	60-180 seconds
Time maintained above:		
-Temperature (TL)	183°C	217°C
- Time (tL)	60-150 seconds	60-150 seconds
Peak Temperature(Tp)	240 +0/-5 °C	260 +0/-5 °C
Time within 5°C of actual peak temperature(tp)	10-30 seconds	20-40 seconds
Ramp down rate	6°C/second max.	6°C/second max.
Time 25 °C to peak temperature	6 minutes max.	8 minutes max.

Note : All temperatures refer to topside of the package, measured on the package body surface.

SOT-323 Dimension

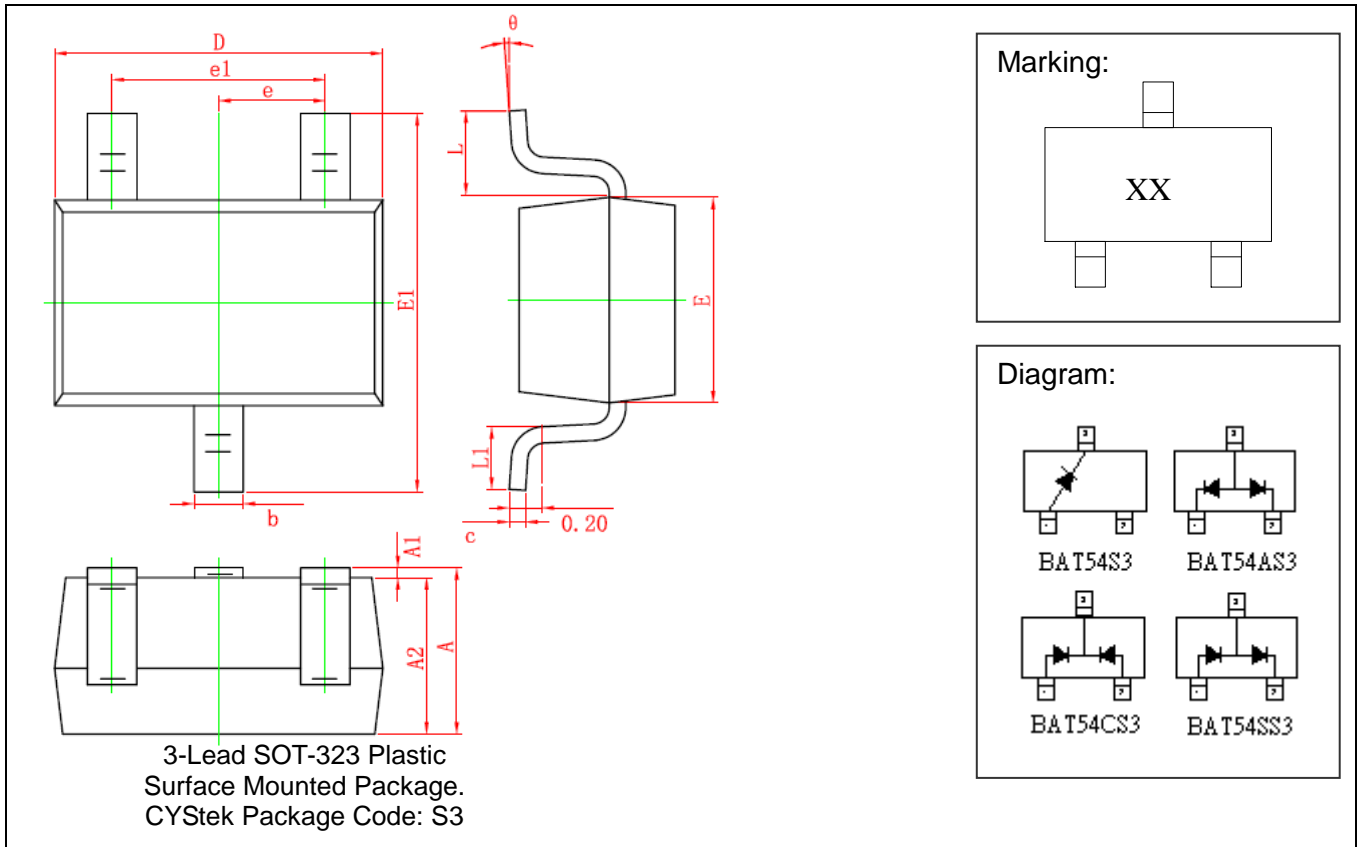

3-Lead SOT-323 Plastic Surface Mounted Package.
 CYStek Package Code: S3

Marking:
 XX

Diagram:
 BAT54S3 BAT54AS3
 BAT54CS3 BAT54SS3

- BAT54 S3 : Single Diode (Marking Code B4)
- BAT54AS3 : Common Anode. (Marking Code B7)
- BAT54CS3 : Common Cathode. (Marking Code 5C)
- BAT54SS3 : Series Connected. (Marking Code B8)

DIM	Millimeters		Inches		DIM	Millimeters		Inches	
	Min.	Max.	Min.	Max.		Min.	Max.	Min.	Max.
A	0.900	1.100	0.035	0.043	E1	2.150	2.450	0.085	0.096
A1	0.000	0.100	0.000	0.004	e	0.650	TYP	0.026	TYP
A2	0.900	1.000	0.035	0.039	e1	1.200	1.400	0.047	0.055
b	0.200	0.400	0.008	0.016	L	0.525	REF	0.021	REF
c	0.080	0.150	0.003	0.006	L1	0.260	0.460	0.010	0.018
D	2.000	2.200	0.079	0.087	θ	0°	8°	0°	8°
E	1.150	1.350	0.045	0.053					

Notes: 1.Controlling dimension: millimeters.
 2.Maximum lead thickness includes lead finish thickness, and minimum lead thickness is the minimum thickness of base material.
 3.If there is any question with packing specification or packing method, please contact your local CYStek sales office.

Material:

- Lead: Pure tin plated.
- Mold Compound: Epoxy resin family, flammability solid burning class: UL94V-0.

Important Notice:

- All rights are reserved. Reproduction in whole or in part is prohibited without the prior written approval of CYStek.
- CYStek reserves the right to make changes to its products without notice.
- CYStek **semiconductor products are not warranted to be suitable for use in Life-Support Applications, or systems.**
- CYStek assumes no liability for any consequence of customer product design, infringement of patents, or application assistance.