



Surface Mount Transient Voltage Suppressors
Peak Pulse Power 200W Working Voltage 5.0 to 190V

SMF5.0A thru SMF190CA

Features

- Glass passivated chip
- Uni and Bidirectional unit
- Excellent clamping capability
- 200W peak pulse power capability with a 10/1000µs waveform, repetition rate (duty cycle) : 0.01%
- Very-fast response time
- Low leakage
- RoHS compliant

Mechanical Data

- Case : Molded plastic
- Terminals: Pure tin plated, solderable per MIL-STD-750 method 2026
- Polarity: For uni-directional types, the band denotes the cathode, which is positive with respect to the anode under normal TVS operation
- Mounting position : Any
- Epoxy: UL 94V-0 rate flame retardant

Devices for bidirectional applications

For bi-directional devices, use suffix CA (e.g. SMF10CA). Electrical characteristics apply in both directions.

Ordering Information

Device	Package	Shipping
SMFXXX(C)A-0-T1-G	SMF (Pb-free lead plating and halogen-free package)	3000 pcs / tape & reel

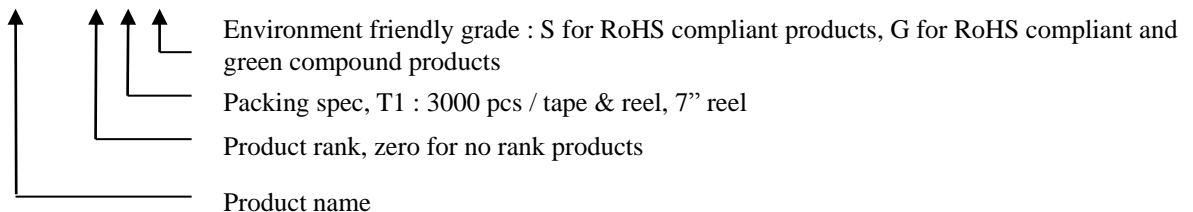



Maximum Ratings and Characteristics($T_A=25^{\circ}\text{C}$, unless otherwise noted)

Parameter	Symbol	Value	Unit
Peak pulse power dissipation with a 10/1000 μs waveform (Note 1)	PPP	200	W
Peak pulse power dissipation with a 8/20 μs waveform (Note 1)	PPP	1000	W
Peak pulse current with a 10/1000 μs waveform (Note 1)	IPP	See next table	A
Peak forward surge current, 8.3ms single half sine wave uni-directional only (Note 2)	IFSM	20	A
Typical thermal resistance, junction to ambient air (Note 3)	R _{thJA}	200	K/W
Typical thermal resistance, junction to Lead (Note 3)	R _{thJL}	100	K/W
Power dissipation on infinite heatsink at $T_L=75^{\circ}\text{C}$	P _D	0.4	W
Maximum instantaneous forward voltage at 25A for unidirectional only	V _F	3.5	V
Operating junction and storage temperature range	T _J ;T _{STG}	-55 ~ +150	$^{\circ}\text{C}$

Notes:

1. Non-repetitive current pulse, per Fig. 5 and derated above $T_A=25^{\circ}\text{C}$ per Fig. 1.
2. Mounted on 8.3ms single half sine-wave or equivalent square wave, duty cycle=4 pulses per minute maximum.
3. Mounted on PCB with 10mm x 10 mm x 2mm Cu pads to each terminal.

Electrical Characteristics Ratings at 25°C ambient temperature, unless otherwise noted.

Part Number (UNI)	Part Number (BI)	Device Marking Code		Breakdown Voltage $V_{(BR)}$ @ I_T			Maximum reverse leakage I_R @ V_{RWM} (μA)	Working Peak reverse voltage V_{RWM} (V)	Maximum reverse surge Current I_{PP} (A)	Maximum clamping voltage V_C @ I_{PP} (V)
		UNI	BI	Min (V)	Max (V)	I_T (mA)				
SMF5.0A	SMF5.0CA	FE	KE	6.40	7.00	10	400	5.0	21.74	9.2
SMF6.0A	SMF6.0CA	FG	KG	6.67	7.37	10	400	6.0	19.42	10.3
SMF6.5A	SMF6.5CA	FK	KK	7.22	7.98	10	250	6.5	17.86	11.2
SMF7.0A	SMF7.0CA	FM	KM	7.78	8.60	10	100	7.0	16.67	12.0
SMF7.5A	SMF7.5CA	FP	KP	8.33	9.21	1	50	7.5	15.50	12.9
SMF8.0A	SMF8.0CA	FR	KR	8.89	9.83	1	25	8.0	14.71	13.6
SMF8.5A	SMF8.5K	FT	KT	9.44	10.40	1	10	8.5	13.89	14.4
SMF9.0A	SMF9.0CA	FV	KV	10.00	11.10	1	5	9.0	12.99	15.4
SMF10A	SMF10CA	FX	KX	11.10	12.30	1	2.5	10.0	11.76	17.0
SMF11A	SMF11CA	FZ	KZ	12.20	13.50	1	2.5	11.0	10.99	18.2
SMF12A	SMF12CA	HE	LE	13.30	14.70	1	2.5	12.0	10.05	19.9
SMF13A	SMF13CA	HG	LG	14.40	15.90	1	1	13.0	9.30	21.5
SMF14A	SMF14CA	HK	LK	15.60	17.20	1	1	14.0	8.62	23.2
SMF15A	SMF15CA	HM	LM	16.70	18.50	1	1	15.0	8.20	24.4
SMF16A	SMF16CA	HP	LP	17.80	19.70	1	1	16.0	7.69	26.0
SMF17A	SMF17CA	HR	LR	18.90	20.90	1	1	17.0	7.25	27.6
SMF18A	SMF18CA	HT	LT	20.00	22.10	1	1	18.0	6.85	29.2
SMF19A	SMF19CA	HB	LB	21.10	23.30	1	1	19.0	6.54	30.6
SMF20A	SMF20CA	HV	LV	22.20	24.50	1	1	20.0	6.17	32.4
SMF22A	SMF22CA	HX	LX	24.40	26.90	1	1	22.0	5.63	35.5
SMF24A	SMF24CA	HZ	LZ	26.70	29.50	1	1	24.0	5.14	38.9



Part Number (UNI)	Part Number (BI)	Device Marking Code		Breakdown Voltage $V_{(BR)}$ @ I_T			Maximum reverse leakage I_R @ V_{RWM} (μA)	Working Peak reverse voltage V_{RWM} (V)	Maximum reverse surge Current I_{PP} (A)	Maximum clamping voltage V_C @ I_{PP} (V)
		UNI	BI	Min (V)	Max (V)	I_T (mA)				
SMF26A	SMF26CA	JE	ME	28.90	31.90	1	1	26.0	4.75	42.1
SMF28A	SMF28CA	JG	MG	31.10	34.40	1	1	28.0	4.41	45.4
SMF30A	SMF30CA	JK	MK	33.30	36.80	1	1	30.0	4.13	48.4
SMF33A	SMF33CA	JM	MM	36.70	40.60	1	1	33.0	3.75	53.3
SMF36A	SMF36CA	JP	MP	40.00	44.20	1	1	36.0	3.44	58.1
SMF40A	SMF40CA	JR	MR	44.40	49.10	1	1	40.0	3.10	64.5
SMF43A	SMF43CA	JT	MT	47.80	52.80	1	1	43.0	2.88	69.4
SMF45A	SMF45CA	JV	MV	50.00	55.30	1	1	45.0	2.75	72.7
SMF48A	SMF48CA	JX	MX	53.30	58.90	1	1	48.0	2.58	77.4
SMF51A	SMF51CA	JZ	MZ	56.70	62.70	1	1	51.0	2.43	82.4
SMF54A	SMF54CA	XE	NE	60.00	66.30	1	1	54.0	2.30	87.1
SMF58A	SMF58CA	XG	NG	64.40	71.20	1	1	58.0	2.14	93.6
SMF60A	SMF60CA	XK	NK	66.70	73.70	1	1	60.0	2.07	96.8
SMF64A	SMF64CA	XM	NM	71.10	78.60	1	1	64.0	1.94	103.0
SMF70A	SMF70CA	XP	NP	77.80	86.00	1	1	70.0	1.77	113.0
SMF75A	SMF75CA	XR	NR	83.30	92.10	1	1	75.0	1.65	121.0
SMF78A	SMF78CA	XT	NT	86.70	95.80	1	1	78.0	1.59	126.0
SMF80A	SMF80CA	XB	NB	88.80	97.60	1	1	80.0	1.55	129.0
SMF85A	SMF85CA	XV	NV	94.40	104.00	1	1	85.0	1.46	137.0
SMF90A	SMF90CA	XX	NX	100.00	111.00	1	1	90.0	1.37	146.0
SMF100A	SMF100CA	XZ	NZ	111.00	123.00	1	1	100.0	1.23	162.0
SMF110A	SMF110CA	TE	PE	122.00	135.00	1	1	110.0	1.13	177.0
SMF120A	SMF120CA	TG	PG	133.00	147.00	1	1	120.0	1.04	193.0
SMF130A	SMF130CA	TK	PK	144.00	159.00	1	1	130.0	0.96	209.0
SMF140A	SMF140CA	TB	PB	155.00	171.00	1	1	140.0	0.89	224.0
SMF150A	SMF150CA	TM	PM	167.00	185.00	1	1	150.0	0.82	243.0
SMF160A	SMF160CA	TP	PP	178.00	197.00	1	1	160.0	0.77	259.0
SMF170A	SMF170CA	TR	PR	189.00	209.00	1	1	170.0	0.73	275.0
SMF180A	SMF180CA	TT	PT	200.00	220.00	1	1	180.0	0.69	292.0
SMF190A	SMF190CA	TV	PV	211.00	232.00	1	1	190.0	0.69	308.0

- Note: 1.Suffix 'A' denotes 5% tolerance device.
 2.Add suffix 'C' or 'CA' after part number to specify Bi-directional devices.
 3.For bidirectional types having V_R of 10 volts and less, the I_R limit is doubled.

Recommended Footprint

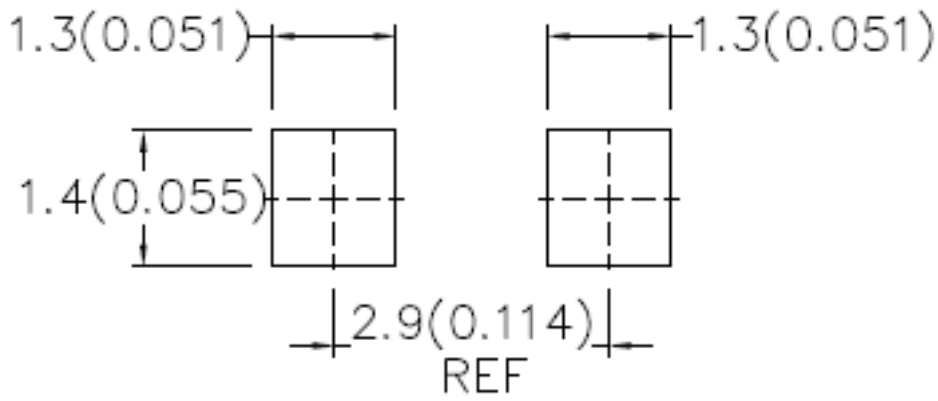

Mounting Pad Layout

Ratings and Characteristics Curves ($T_A=25^\circ\text{C}$ unless otherwise noted)



Fig. 1 - Pulse Derating Curve

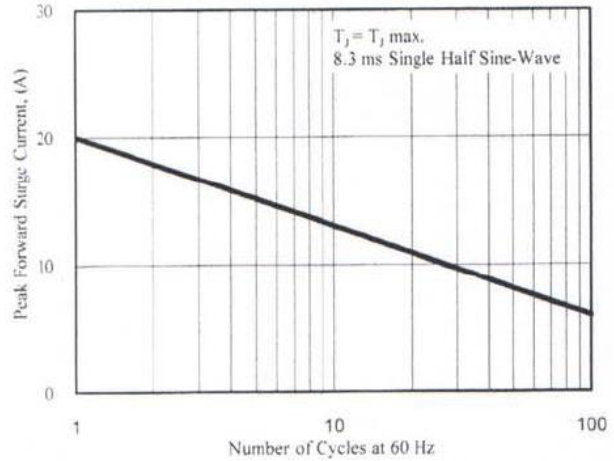

Fig. 2 - Maximum Non-Repetitive Surge Current

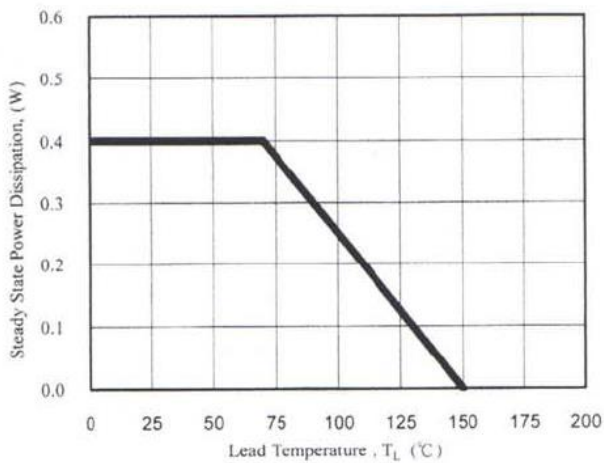

Fig. 3 - Steady State Power Derating Curve



Fig. 4 - Peak Pulse Power Rating Curve

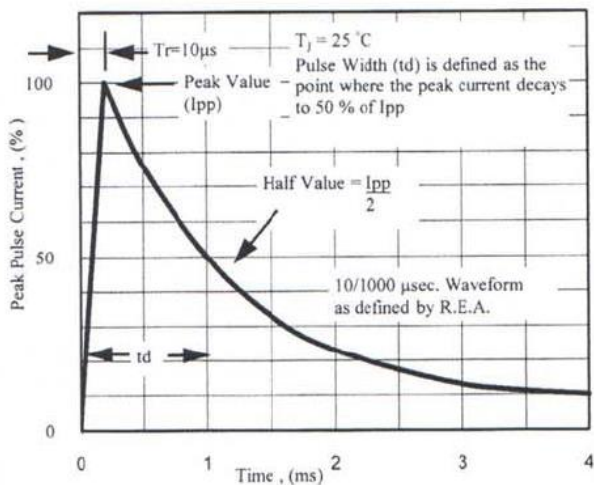

Fig. 5 - Pulse Waveform

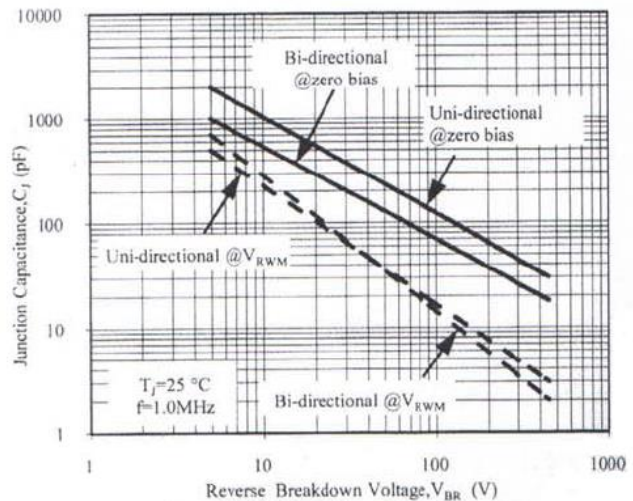
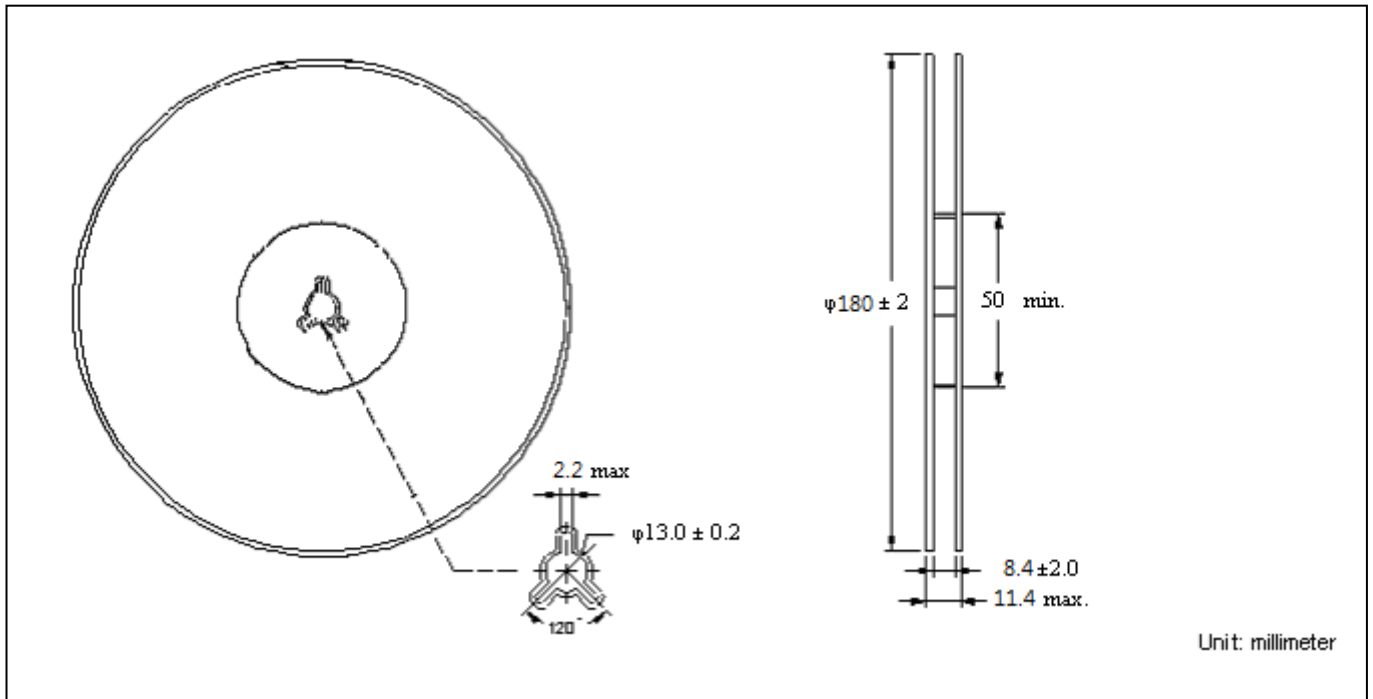
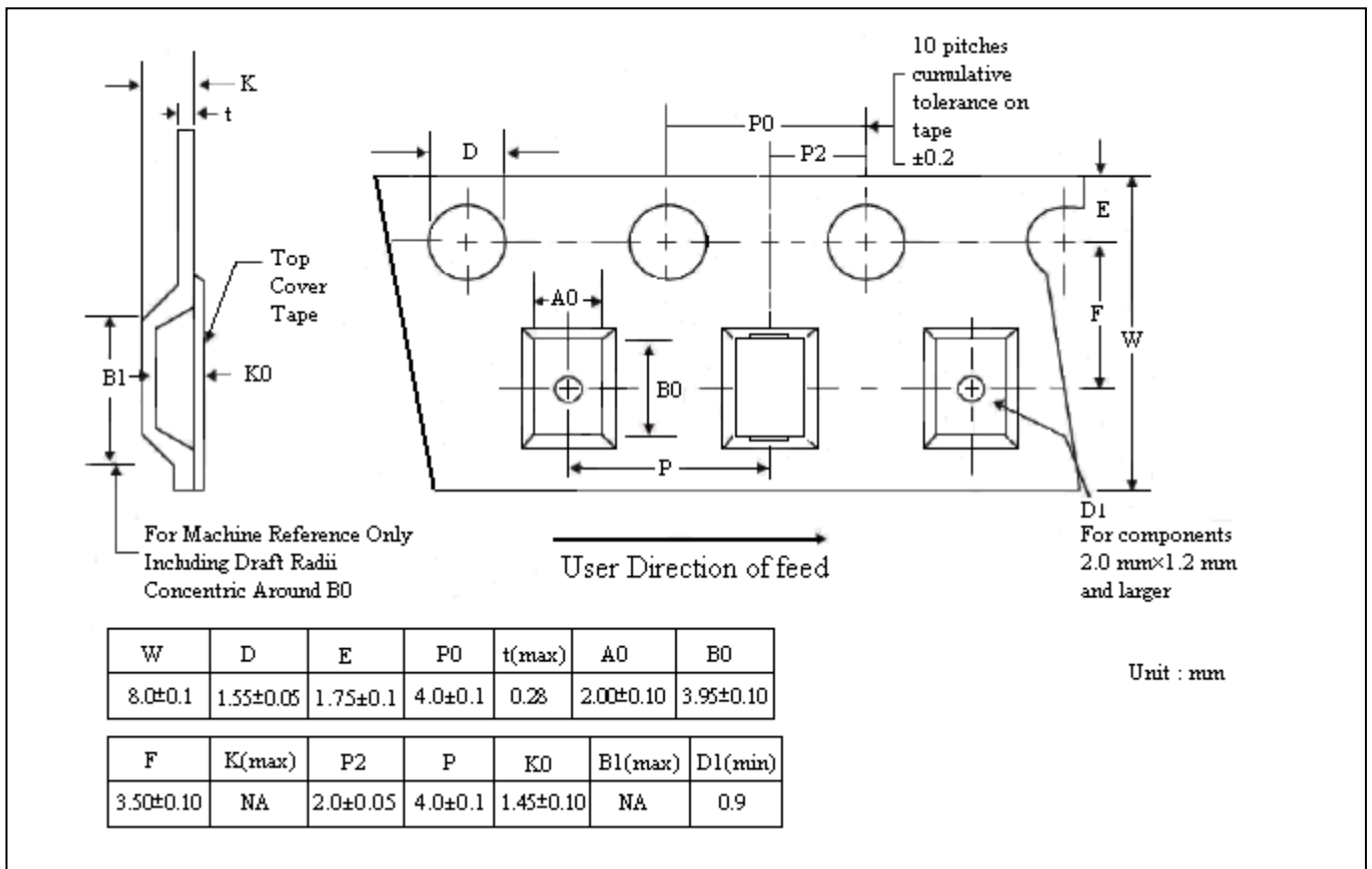

Fig. 6 - Typical Junction Capacitance

Reel Dimension



Carrier Tape Dimension



Recommended Wave Soldering Profile

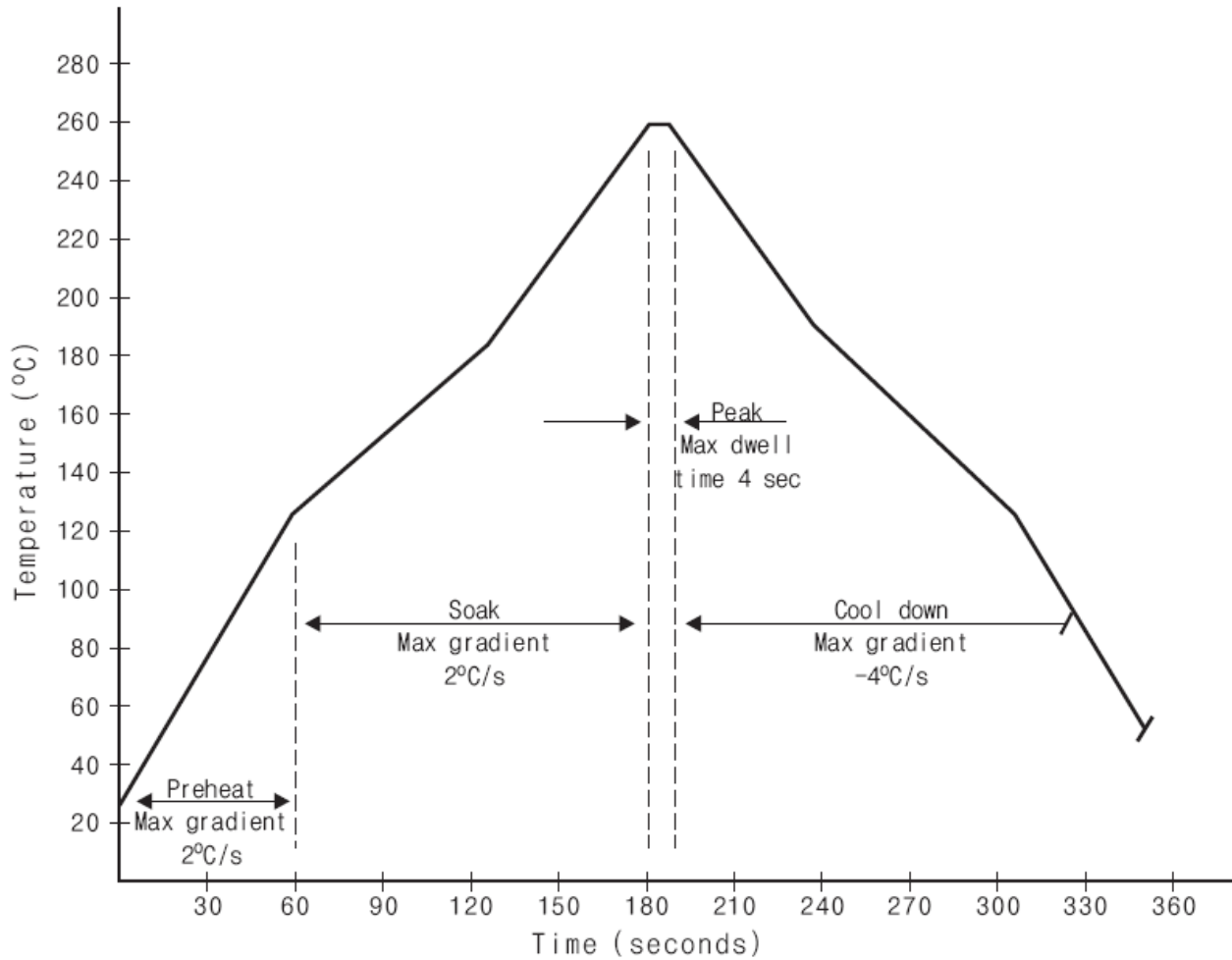

Recommended wave soldering condition

Product	Peak Temperature	Soldering Time
Pb-free devices	260 +0/-5 °C	5 +1/-1 seconds

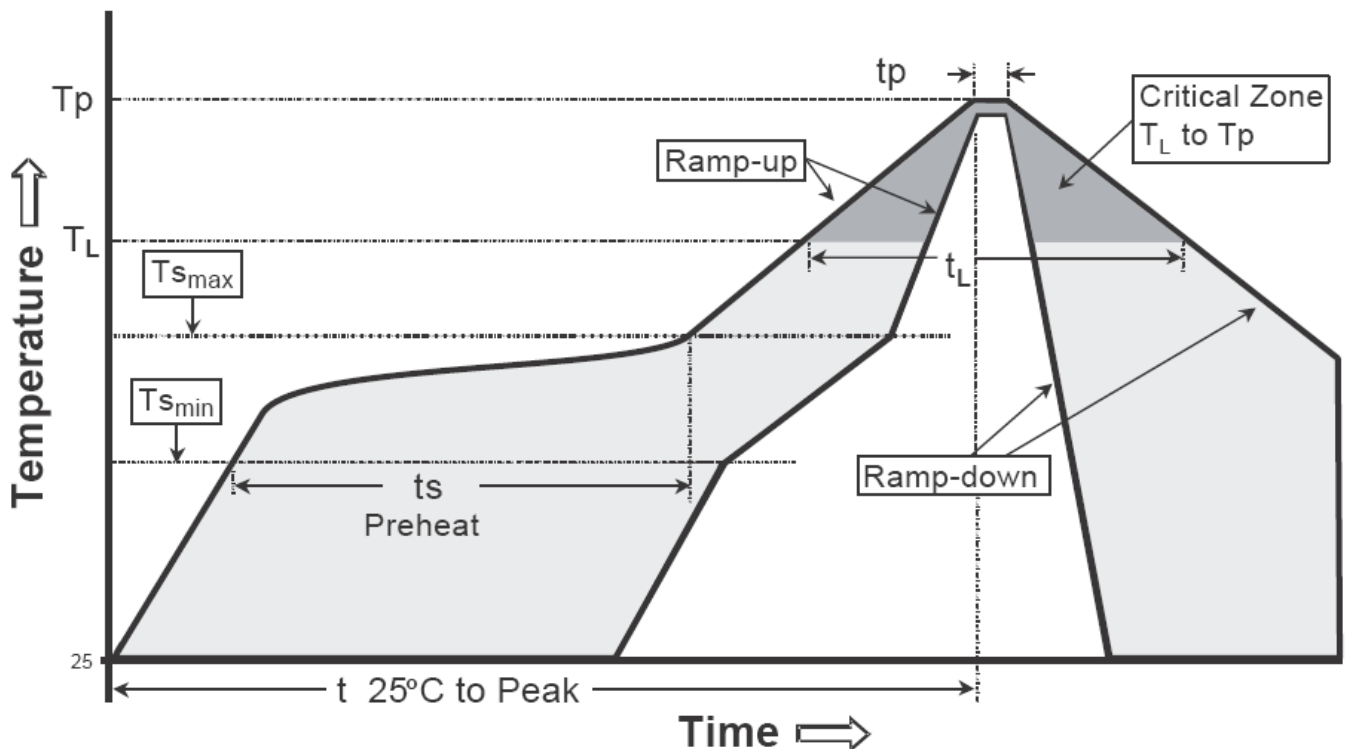
Recommended temperature profile for IR reflow

Profile feature	Sn-Pb eutectic Assembly	Pb-free Assembly
Average ramp-up rate (Tsmax to Tp)	3°C/second max.	3°C/second max.
Preheat		
-Temperature Min(Ts min)	100°C	150°C
-Temperature Max(Ts max)	150°C	200°C
-Time(ts min to ts max)	60-120 seconds	60-180 seconds
Time maintained above:		
-Temperature (TL)	183°C	217°C
- Time (tL)	60-150 seconds	60-150 seconds
Peak Temperature(TP)	240 +0/-5 °C	260 +0/-5 °C
Time within 5°C of actual peak temperature(tp)	10-30 seconds	20-40 seconds
Ramp down rate	6°C/second max.	6°C/second max.
Time 25 °C to peak temperature	6 minutes max.	8 minutes max.

Note : All temperatures refer to topside of the package, measured on the package body surface.

SMF Dimension

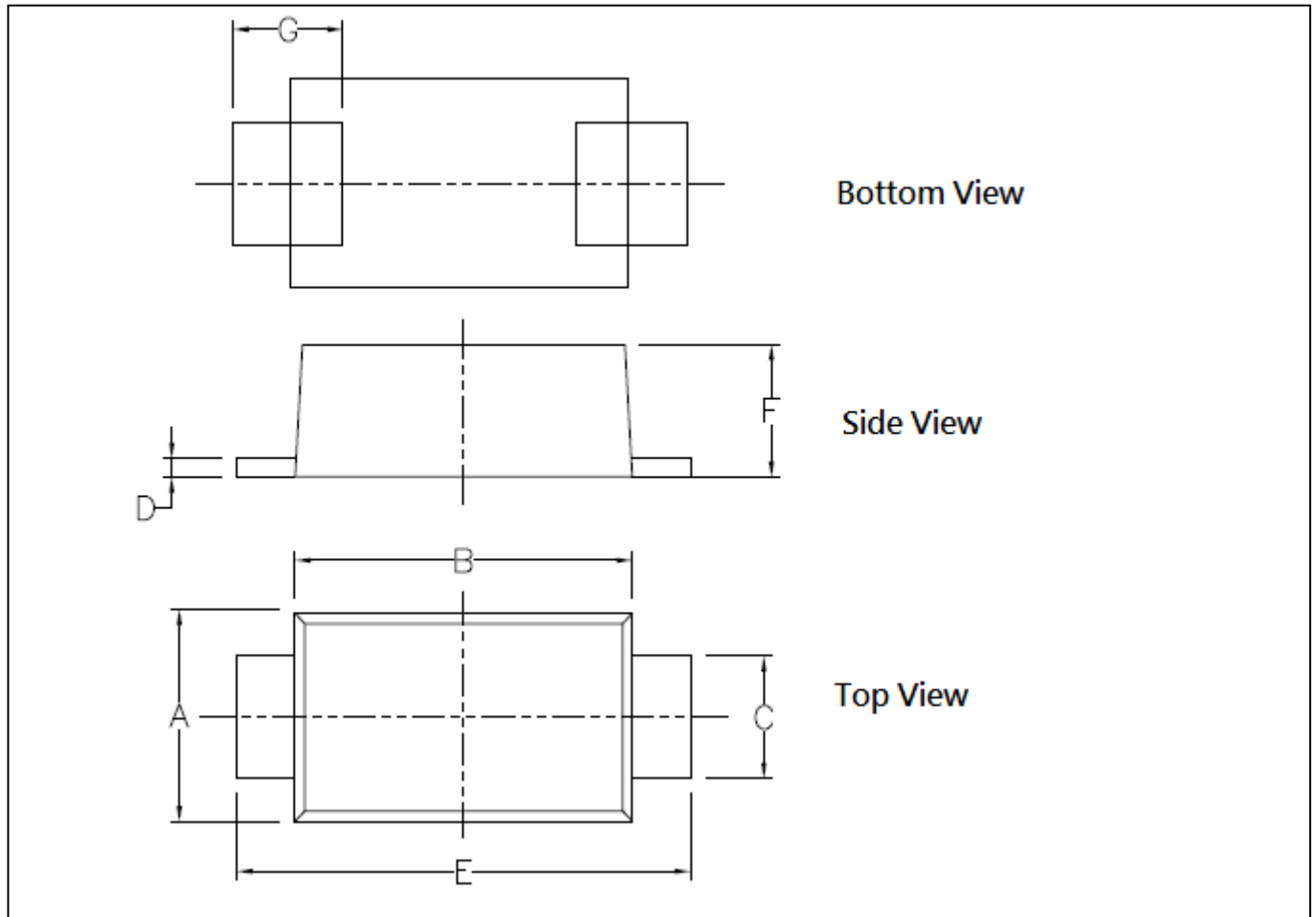

DIM	Millimeters		Inches		DIM	Millimeters		Inches	
	Min.	Max.	Min.	Max.		Min.	Max.	Min.	Max.
A	1.60	1.90	0.063	0.075	E	3.50	3.90	0.138	0.154
B	2.60	2.90	0.102	0.114	F	0.95	1.30	0.037	0.051
C	0.70	1.20	0.028	0.047	G	0.35	0.85	0.014	0.033
D	0.05	0.25	0.002	0.010	H				

Notes : 1.Controlling dimension : millimeters.
 2.Maximum lead thickness includes lead finish thickness, and minimum lead thickness is the minimum thickness of base material.
 3.If there is any question with packing specification or packing method, please contact your local CYStek sales office.

Material :

- Lead : Pure tin plated.
- Mold Compound : Epoxy resin family, flammability solid burning class:UL94V-0.

Important Notice:

- All rights are reserved. Reproduction in whole or in part is prohibited without the prior written approval of CYStek.
- CYStek reserves the right to make changes to its products without notice.
- CYStek **semiconductor products are not warranted to be suitable for use in Life-Support Applications, or systems.**
- CYStek assumes no liability for any consequence of customer product design, infringement of patents, or application assistance.