

10Amp. Trench Schottky Ultra Low RECTIFIER

SKT10100AJ3

$I_{F(AV)}$	10A
V_{RRM}	100V
V_F at 125°C	0.58V
T_j	150°C

Features

- 150°C operating junction temperature
- Softest, fast switching capability
- Reduced ultra-low forward voltage drop (VF) ; better efficiency and cooler operation.
- Lead-Free Finish; RoHS Compliant
- Halogen and Antimony Free. “Green” Device
- Trench technology provides a superior avalanche capability

Mechanical Data

- Case: TO-252 molded plastic
- Weight: 0.34 grams approximately
- Terminals: Pure tin plated, lead-free, solderable per MIL-STD-750 method 2026
- Epoxy: UL 94V-0 rate flame retardant
- Polarity : As marked.

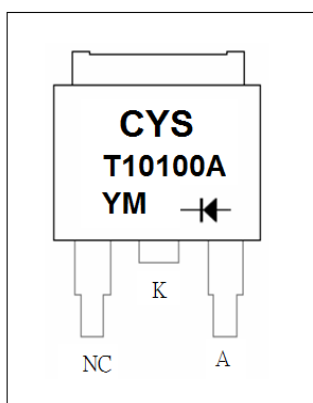
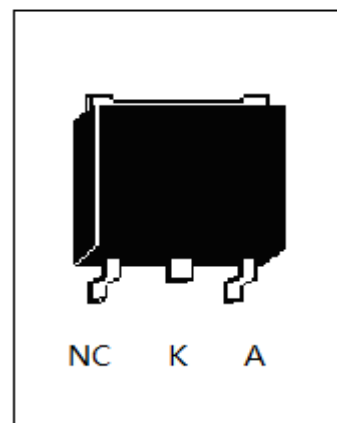
Equivalent Circuit

Outline

TO-252



Maximum Ratings and Electrical Characteristics

(Rating at 25°C ambient temperature unless otherwise specified. Single phase, half wave, 60Hz, resistive or inductive load. For capacitive load, derate current by 20%.)

Parameter	Symbol	Min.	Typ.	Max.	Units
Maximum DC blocking voltage	V _{DC}			100	V
Maximum Recurrent peak reverse voltage	V _{RRM}			100	V
Maximum RMS voltage	V _{RMS}			70	V
instantaneous forward voltage at I _F =5A	V _F	T _C =25°C	0.54	-	V
		T _C =125°C	0.50	-	
instantaneous forward voltage at I _F =10A	V _F	T _C =25°C	0.65	0.72	V
		T _C =125°C	0.58	0.66	
Maximum instantaneous reverse current at	I _R	V _R =100 V, T _C =25°C	25	200	μA
		V _R =100 V, T _C =125°C	12	25	mA
Maximum Average forward rectified current	I _{F(AV)}			10	A
Non-repetitive peak forward surge current @ 8.3ms single half sine wave superimposed on rated load (JEDEC method)	I _{FSM}	150			A
Peak Repetitive Reverse Surge Current (2uS-1Khz)	I _{RRM}			2	A
Storage temperature range	T _{stg}	-55		150	°C
Operating junction temperature range	T _J	-55		150	°C

Thermal Data

Parameter	Symbol	Value	Unit
Typical Thermal Resistance, Junction-to-case	R _{th,j-c}	3	°C/W
Typical Thermal Resistance, Junction-to-ambient	R _{th,j-a}	125	°C/W

Ordering Information

Device	Package	Shipping
SKT10100AJ3-0-T3-G	TO-252 (Pb-free lead plating and Halogen-free package)	2500/Tape & Reel

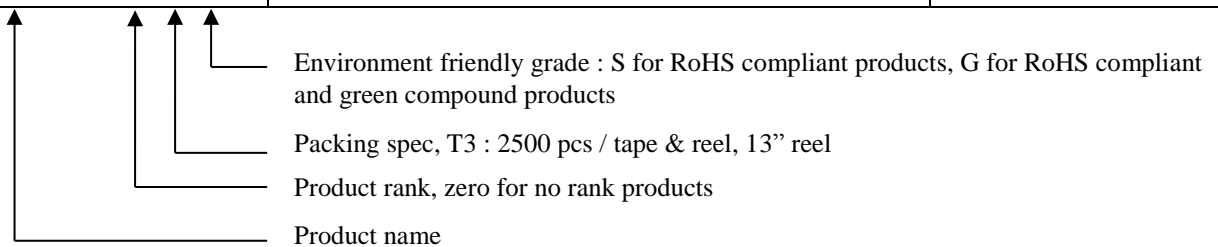

Typical Characteristics

Forward Current Derating Curve

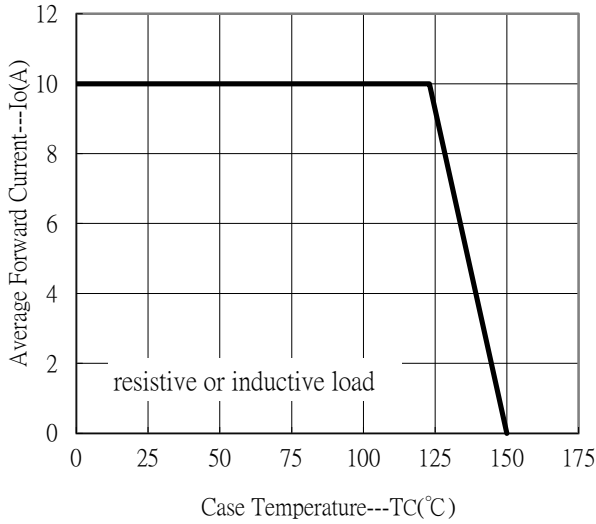

Forward Current vs Forward Voltage

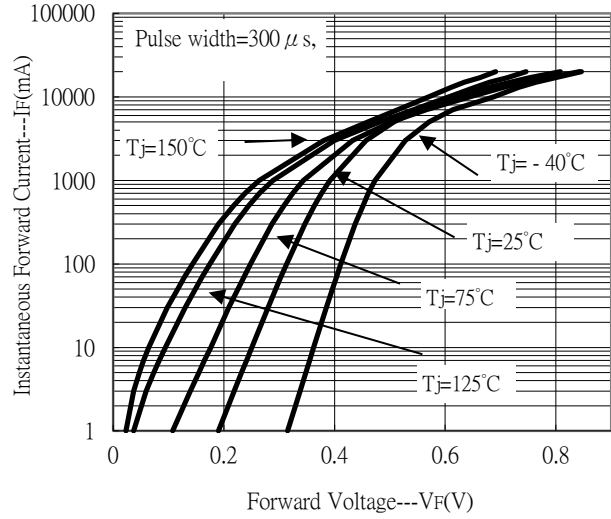

Reverse Leakage Current vs Reverse Voltage

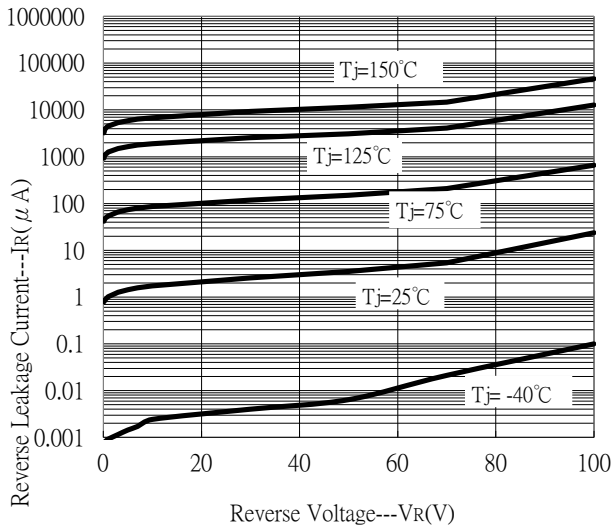

Junction Capacitance vs Reverse Voltage

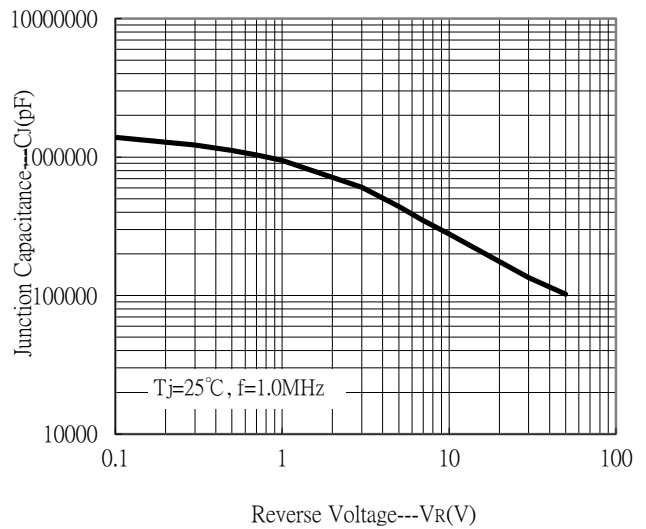

Recommended solering footprint

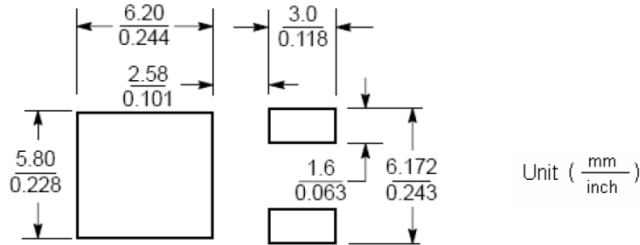

Recommended wave soldering condition

Product	Peak Temperature	Soldering Time
Pb-free devices	260 +0/-5 °C	5 +1/-1 seconds

Recommended temperature profile for IR reflow

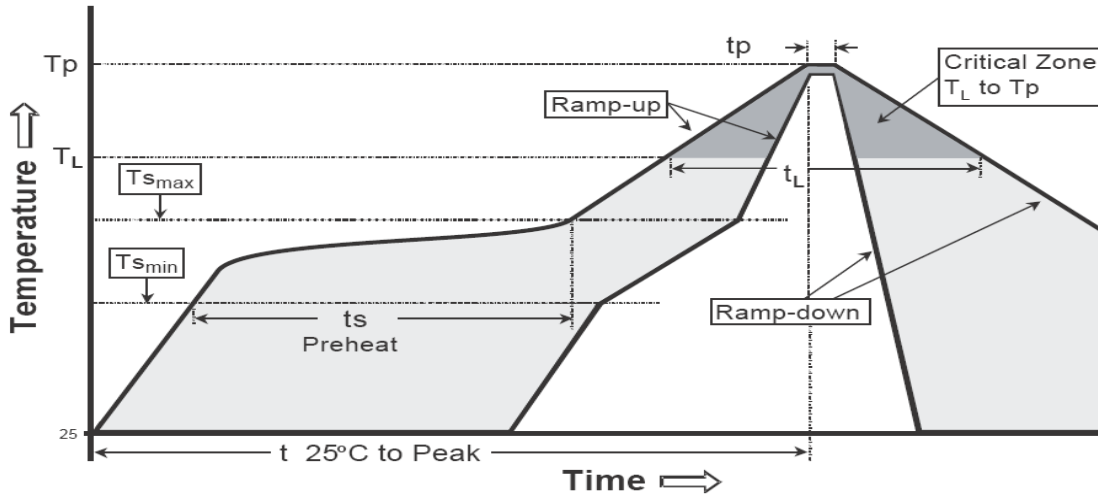

Profile feature	Sn-Pb eutectic Assembly	Pb-free Assembly
Average ramp-up rate (T _{smax} to T _p)	3°C/second max.	3°C/second max.
Preheat		
-Temperature Min(T _{s min})	100°C	150°C
-Temperature Max(T _{s max})	150°C	200°C
-Time(t _{s min} to t _{s max})	60-120 seconds	60-180 seconds
Time maintained above:		
-Temperature (T _L)	183°C	217°C
- Time (t _L)	60-150 seconds	60-150 seconds
Peak Temperature(T _p)	240 +0/-5 °C	260 +0/-5 °C
Time within 5°C of actual peak temperature(tp)	10-30 seconds	20-40 seconds
Ramp down rate	6°C/second max.	6°C/second max.
Time 25 °C to peak temperature	6 minutes max.	8 minutes max.

Note : All temperatures refer to topside of the package, measured on the package body surface.

Reel Dimension

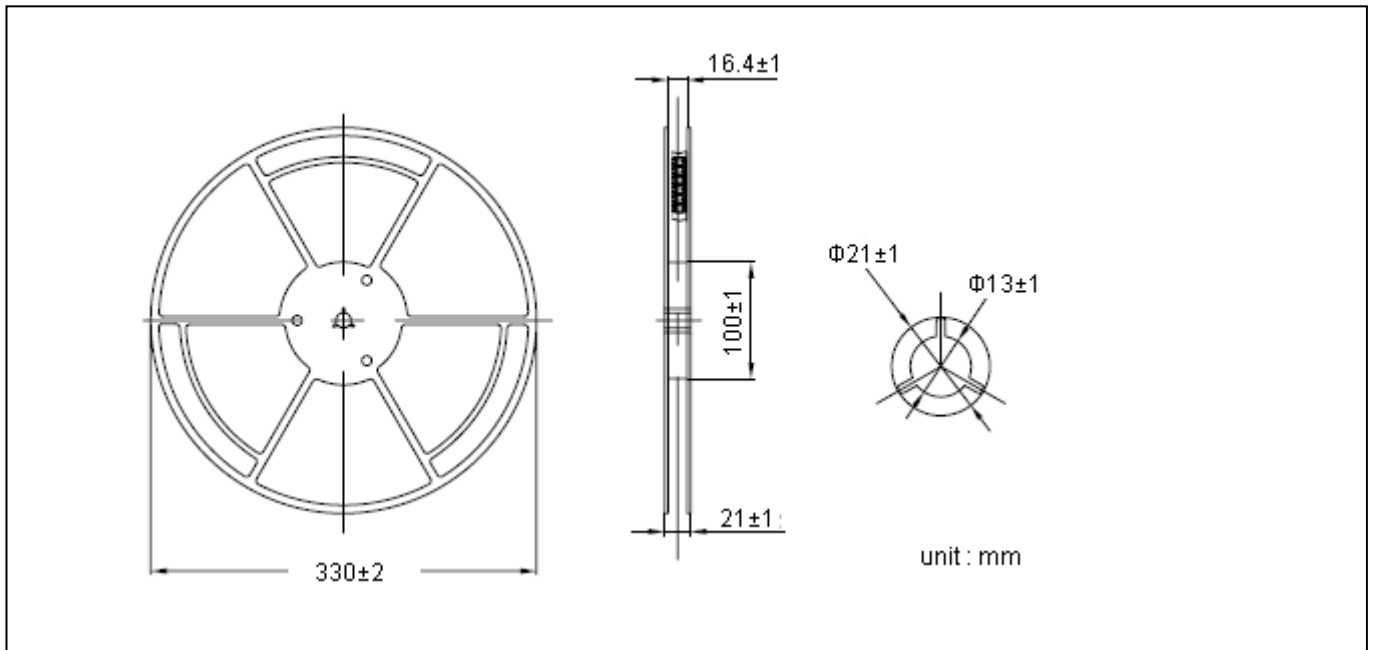

Carrier Tape Dimension

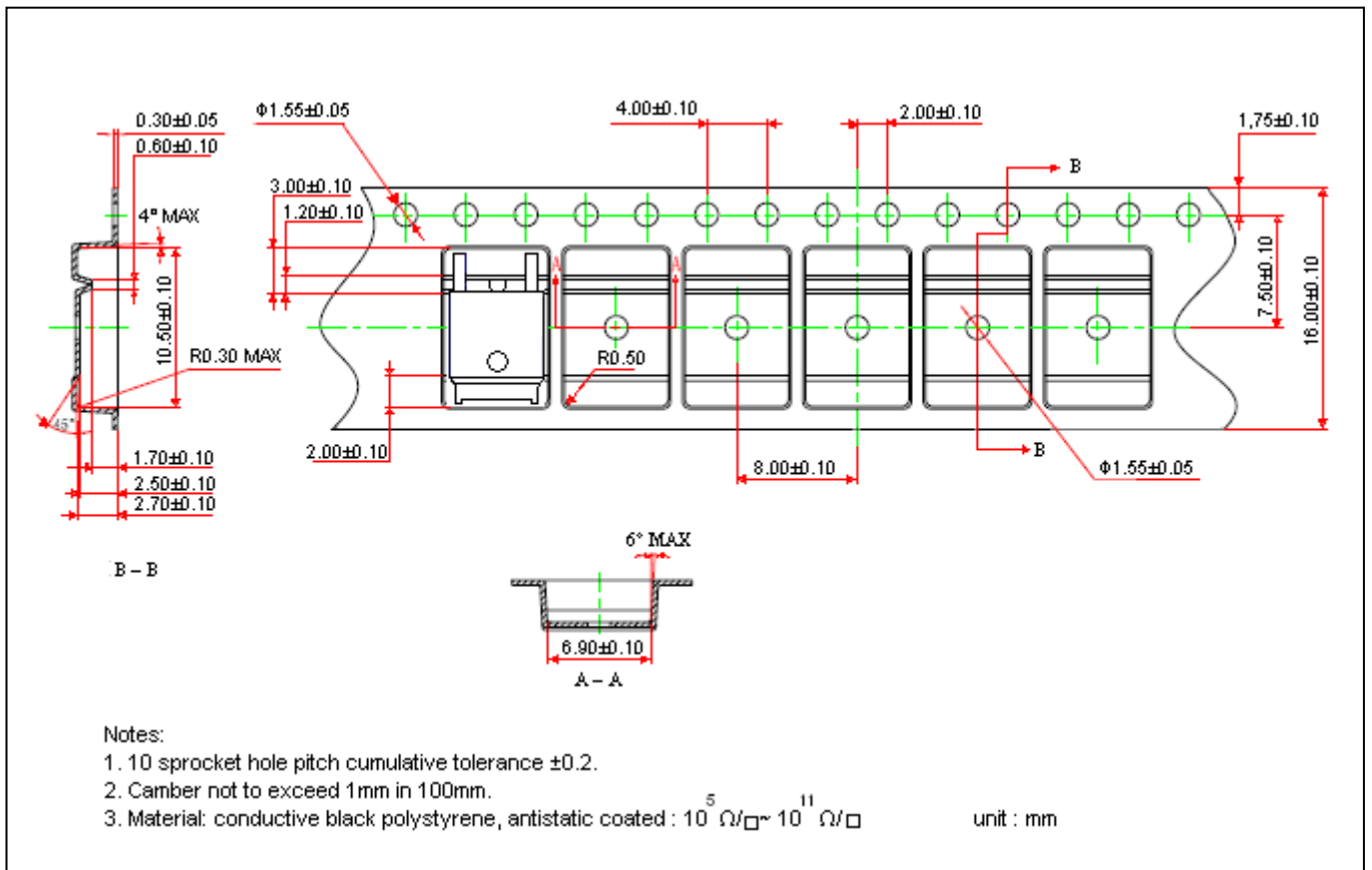

TO-252 Dimension

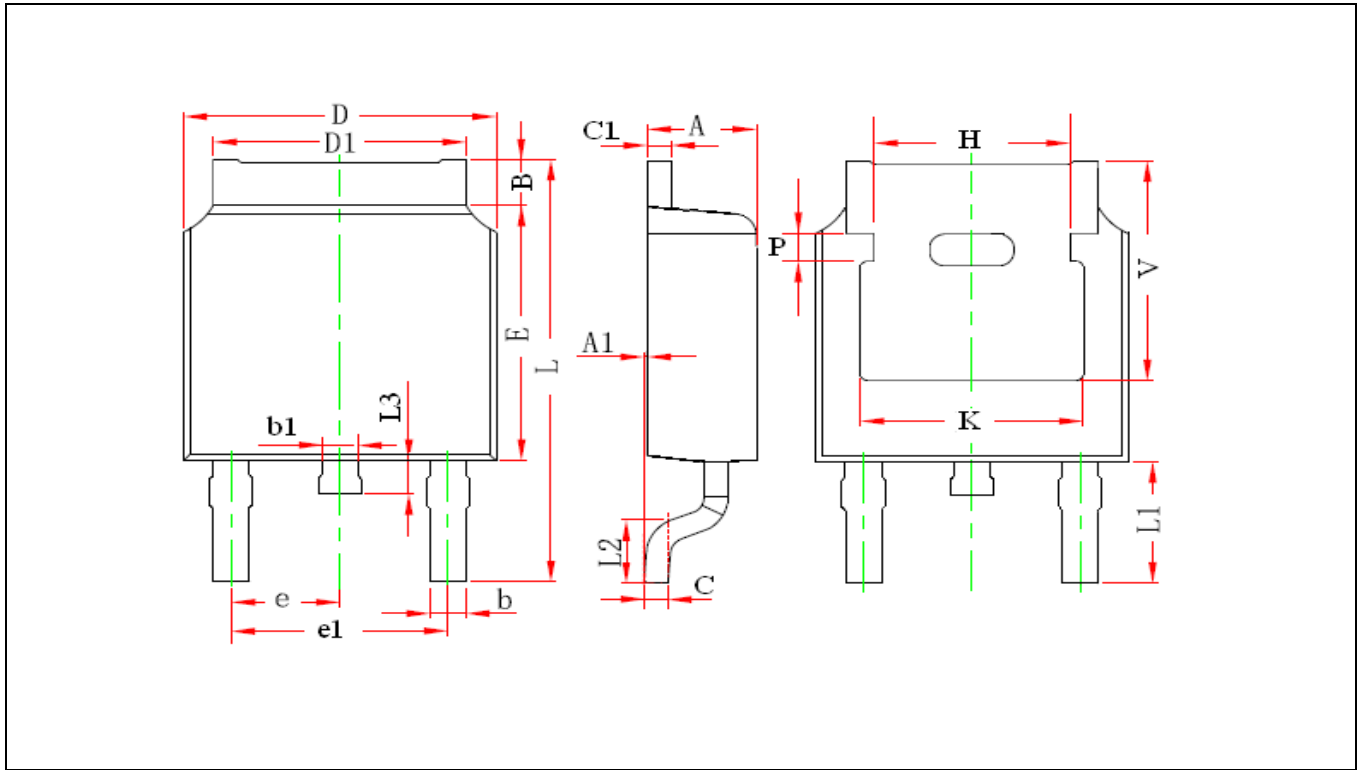

*: Typical

DIM	Inches		Millimeters		DIM	Inches		Millimeters	
	Min.	Max.	Min.	Max.		Min.	Max.	Min.	Max.
A	0.087	0.094	2.200	2.400	e	0.086	0.094	2.186	2.386
A1	0.000	0.005	0.000	0.127	e1	0.172	0.188	4.372	4.772
B	0.039	0.048	0.990	1.210	H	0.163	REF	4.140	REF
b	0.026	0.034	0.660	0.860	K	0.190	REF	4.830	REF
b1	0.026	0.034	0.660	0.860	L	0.386	0.409	9.800	10.400
C	0.018	0.023	0.460	0.580	L1	0.114	REF	2.900	REF
C1	0.018	0.023	0.460	0.580	L2	0.055	0.067	1.400	1.700
D	0.256	0.264	6.500	6.700	L3	0.024	0.039	0.600	1.000
D1	0.201	0.215	5.100	5.460	P	0.030	REF	0.750	REF
E	0.236	0.244	6.000	6.200	V	0.211	REF	5.350	REF

Notes: 1.Controlling dimension: millimeters.
 2.Maximum lead thickness includes lead finish thickness, and minimum lead thickness is the minimum thickness of base material.
 3.If there is any question with packing specification or packing method, please contact your local CYStek sales office.

Material:

- Lead : Pure tin plated
- Mold Compound: Epoxy resin family, flammability solid burning class: UL94V-0

Important Notice:

- All rights are reserved. Reproduction in whole or in part is prohibited without the prior written approval of CYStek.
- CYStek reserves the right to make changes to its products without notice.
- CYStek **semiconductor products are not warranted to be suitable for use in Life-Support Applications, or systems.**
- CYStek assumes no liability for any consequence of customer product design, infringement of patents, or application assistance.