

Product Summary

V_{RRM}	650	V
$I_F @ T_C=137^\circ\text{C}$	10	A
$Q_C @ V_R=400\text{V}$	31	nC

TO-252-2L

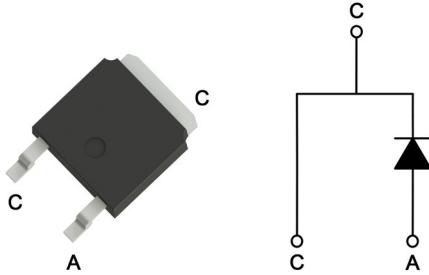

Ordering Information

Device	Package	Shipping
SCD10065J2-0-T3-G	TO-252-2L	2500pcs / Tape & Reel

0: Product rank, zero for no rank products.

T3: Packing spec, T3 : 2500pcs / tape & reel, 13" reel

G: Environment friendly grade: S for RoHS compliant products, G for RoHS compliant and green compound products.

Features

- Negligible reverse recovery
- High surge current
- Positive temperature coefficient
- Pb-free lead plating and halogen-free

Marking

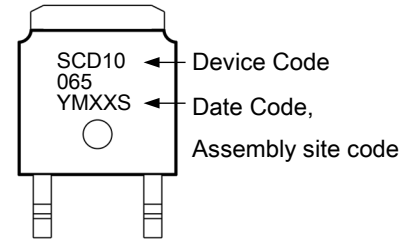

YMXX: Date Code Marking

Y: Year Code, the last digit of Christian year

M: Month Code

A: Jan	B: Feb	C: Mar	D: Apr	E: May	F: Jun
G: Jul	H: Aug	J: Sep	K: Oct	L: Nov	M: Dec

XX: Production Serial Number, 01~99

S: Assembly site code, Site 1: A

Absolute Maximum Ratings ($T_A=25^\circ\text{C}$)

Parameter	Symbol	Value	Unit	
Repetitive Peak Reverse Voltage	V_{RRM}	650	V	
Continuous Forward Current @ $T_C=25^\circ\text{C}$	I_F	22.2	A	
Continuous Forward Current @ $T_C=124^\circ\text{C}$		12		
Continuous Forward Current @ $T_C=137^\circ\text{C}$		10		
Non-repetitive Forward Surge Current @ $T_C=25^\circ\text{C}$	*a I_{FSM}	78		
I^2t limit Value @ $T_C=25^\circ\text{C}$, $t_p=10\text{ms}$	I^2t	30.4	A^2s	
Total Power Dissipation	P_D	$T_C=25^\circ\text{C}$	100	W
		$T_C=110^\circ\text{C}$	43	
		$T_A=25^\circ\text{C}$ *b	3.8	
		$T_A=110^\circ\text{C}$ *b	1.6	
Operating Junction and Storage Temperature Range	T_J, T_{stg}	-55~+175	$^\circ\text{C}$	
Steady State Thermal Resistance, Junction-to-Case	$R_{\theta JC}$	1.5	$^\circ\text{C}/\text{W}$	
Steady State Thermal Resistance, Junction-to-Ambient	*b $R_{\theta JA}$	40		

Electrical Characteristics ($T_J=25^\circ\text{C}$, unless otherwise specified)

Symbol	Min.	Typ.	Max.	Unit	Test Conditions
Static					
V_R	650	-	-	V	$I_R=50\mu\text{A}$
V_F	-	1.35	1.6	V	$I_F=10\text{A}$, $T_J=25^\circ\text{C}$
	-	1.65	-		$I_F=10\text{A}$, $T_J=175^\circ\text{C}$
I_R	-	2.9	50	μA	$V_R=650\text{V}$, $T_J=25^\circ\text{C}$
	-	14	-		$V_R=650\text{V}$, $T_J=175^\circ\text{C}$
Dynamic					
C_J	-	574	-	pF	$V_R=0\text{V}$, $f=1\text{MHz}$
	-	61	-		$V_R=200\text{V}$, $f=1\text{MHz}$
	-	60	-		$V_R=400\text{V}$, $f=1\text{MHz}$
Q_C	-	31	-	nC	$V_R=400\text{V}$, $f=1\text{MHz}$
E_C	-	5.1	-	μJ	$V_R=400\text{V}$, $f=1\text{MHz}$

Note:

*a. Square wave, $t_p=10\text{ms}$.

*b. The value of $R_{\theta JA}$ is measured with the device mounted on 1in^2 FR-4 board with 2oz copper, in a still air environment with $T_A=25^\circ\text{C}$. The value in any given application depends on the user's specific board design.

*c. Pulse Test : Pulse Width $\leq 300\mu\text{s}$, Duty Cycle $\leq 2\%$.

Typical Characteristics

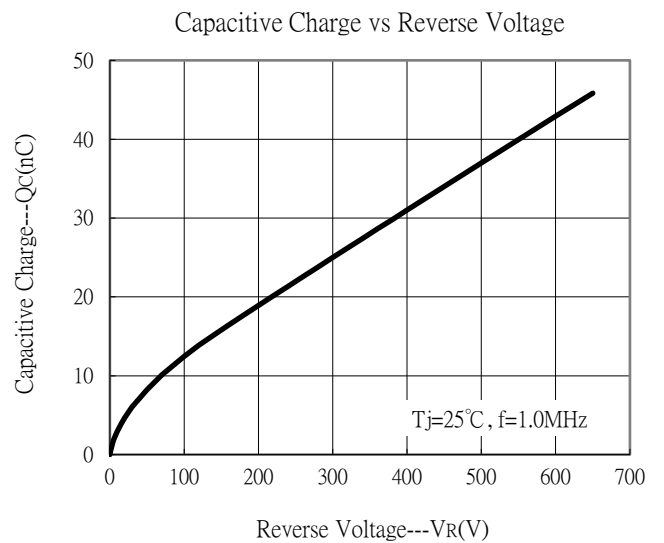
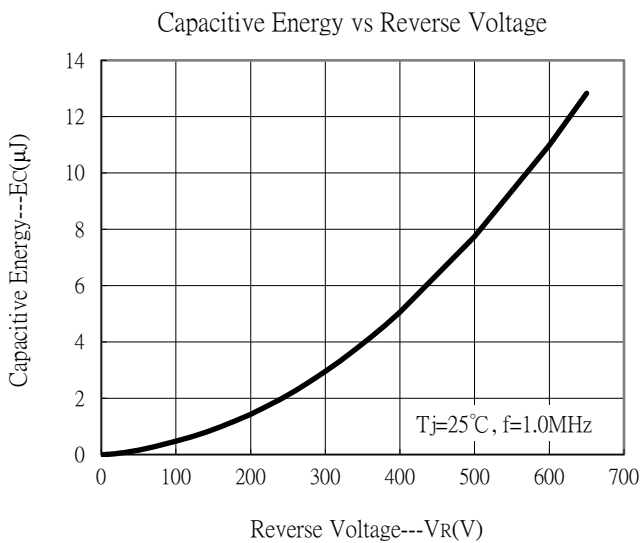
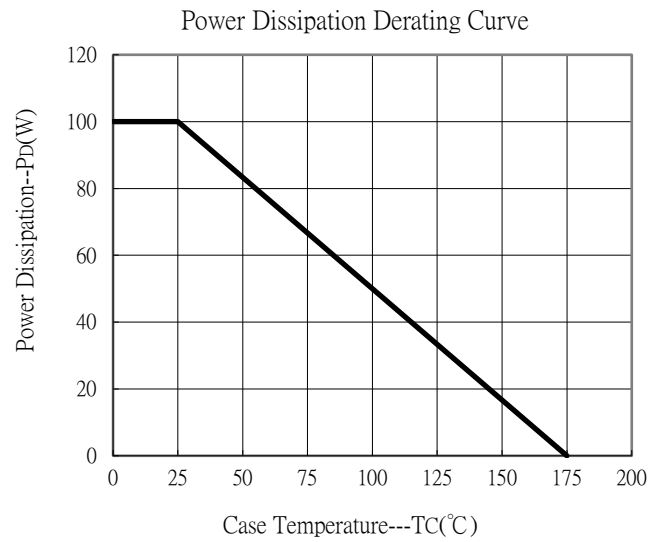
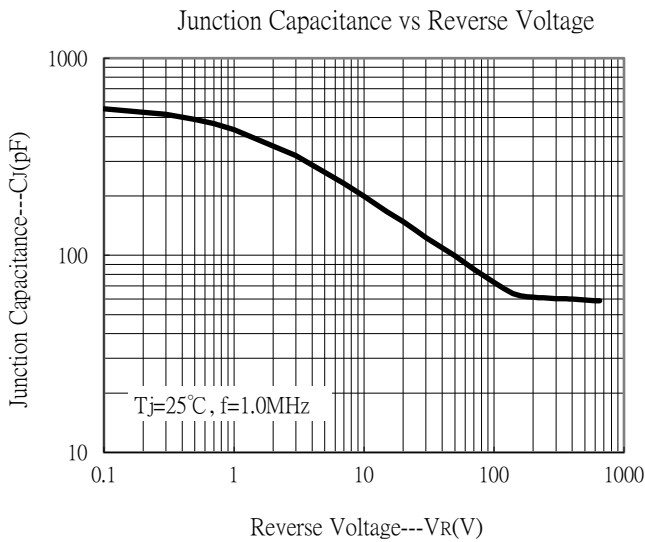
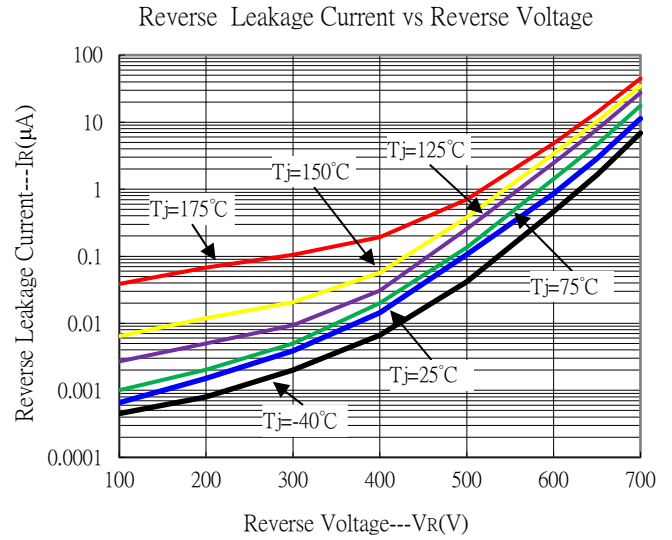
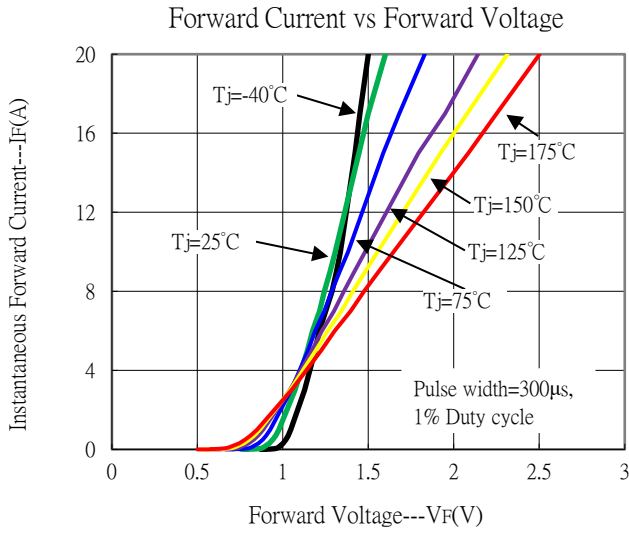



Typical Characteristics (Cont.)

Peak Forward Current vs Case Temperature

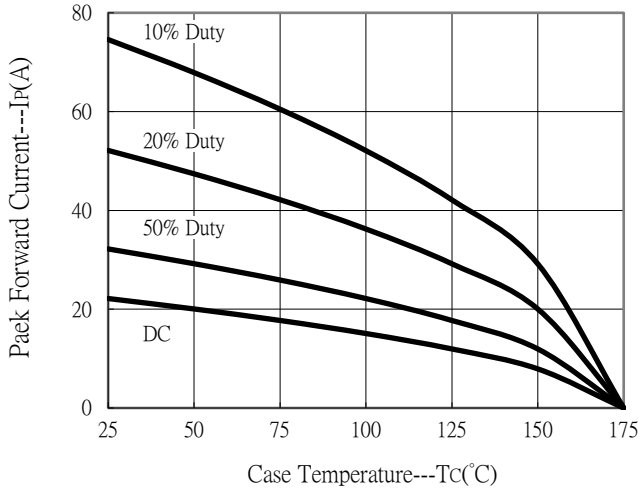

Typical Transient Thermal Impedance

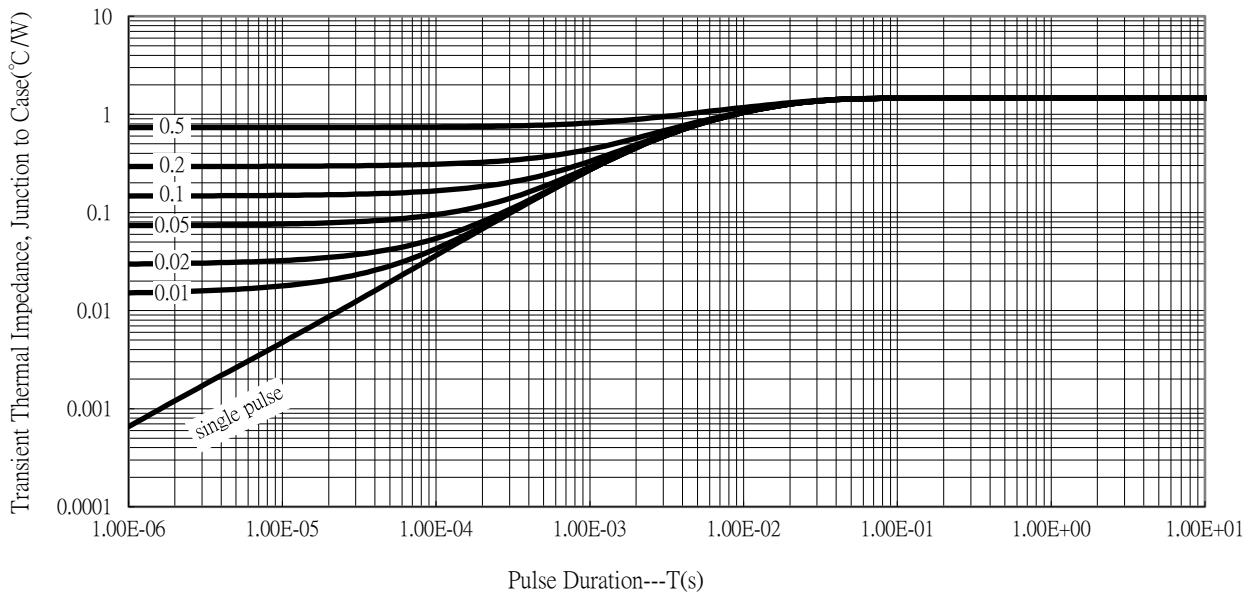

TO-252-2L Dimension

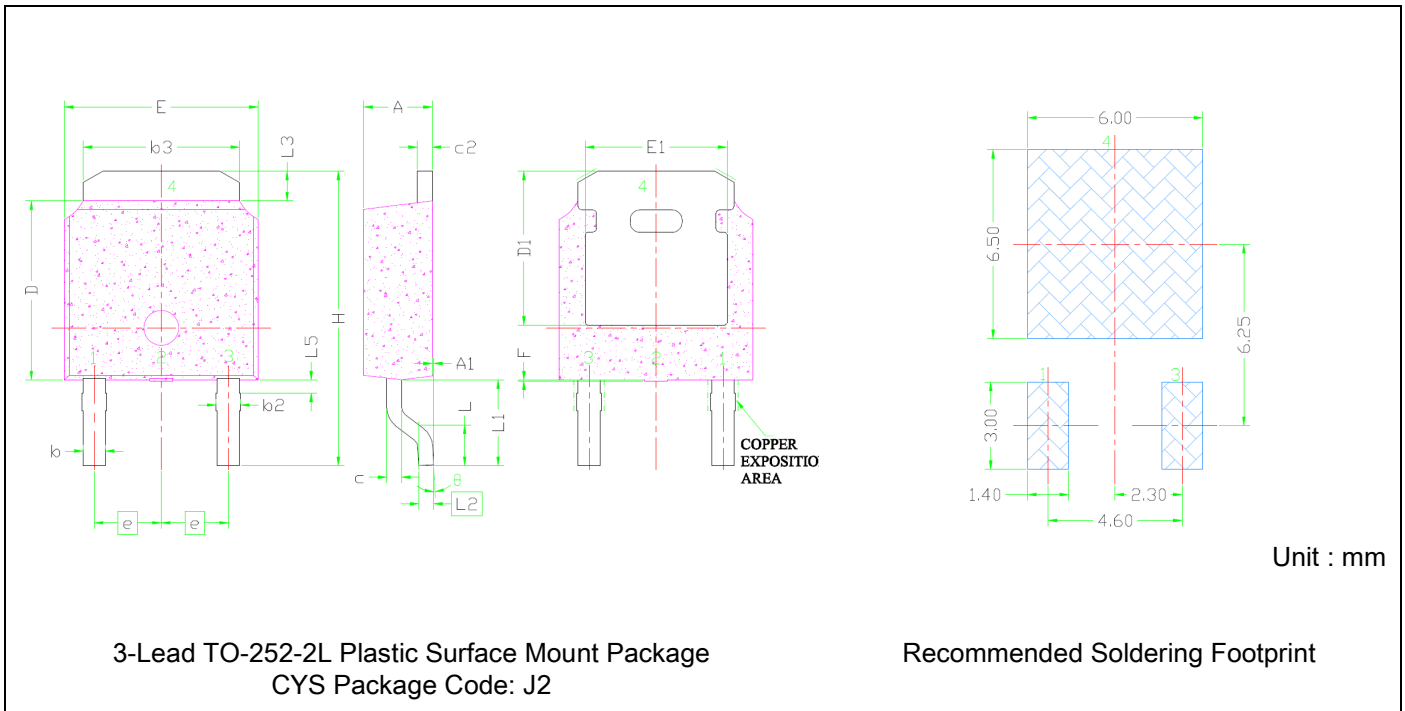

DIM	Millimeters		Inches		DIM	Millimeters		Inches	
	Min.	Max.	Min.	Max.		Min.	Max.	Min.	Max.
E	6.400	6.731	0.252	0.265	b3	5.210	5.460	0.205	0.215
L	1.400	1.770	0.055	0.070	e	2.286	BSC	0.090	BSC
L1	2.743	REF	0.108	REF	A	2.200	2.380	0.087	0.094
L2	0.508	BSC	0.020	BSC	A1	0.000	0.127	0.000	0.005
L3	0.890	1.270	0.035	0.050	c	0.460	0.600	0.018	0.024
L5	-	-	-	-	c2	0.460	0.580	0.018	0.023
D	6.000	6.223	0.236	0.245	D1	5.210	-	0.205	-
H	9.400	10.400	0.370	0.409	E1	4.400	-	0.173	-
b	0.640	0.880	0.025	0.035	F	-	0.450	-	0.018
b2	0.770	1.140	0.030	0.045	θ	0°	10°	0°	10°

Note:

- Controlling dimension: millimeters.
- Maximum lead thickness includes lead finish thickness, and minimum lead thickness is the minimum thickness of base material.
- If there is any question with packing specification or packing method, please contact your local CYStek sales office.

Material:

- Lead: pure tin plated.
- Mold Compound: Epoxy resin family, flammability solid burning class: UL94V-0.

Important Notice:

- All rights are reserved. Reproduction in whole or in part is prohibited without the prior written approval of CYStek.
- CYStek reserves the right to make changes to its products without notice.
- CYStek semiconductor products are not warranted to be suitable for use in Life-Support Applications, or systems.
- CYStek assumes no liability for any consequence of customer product design, infringement of patents, or application assistance.

Reel Dimension

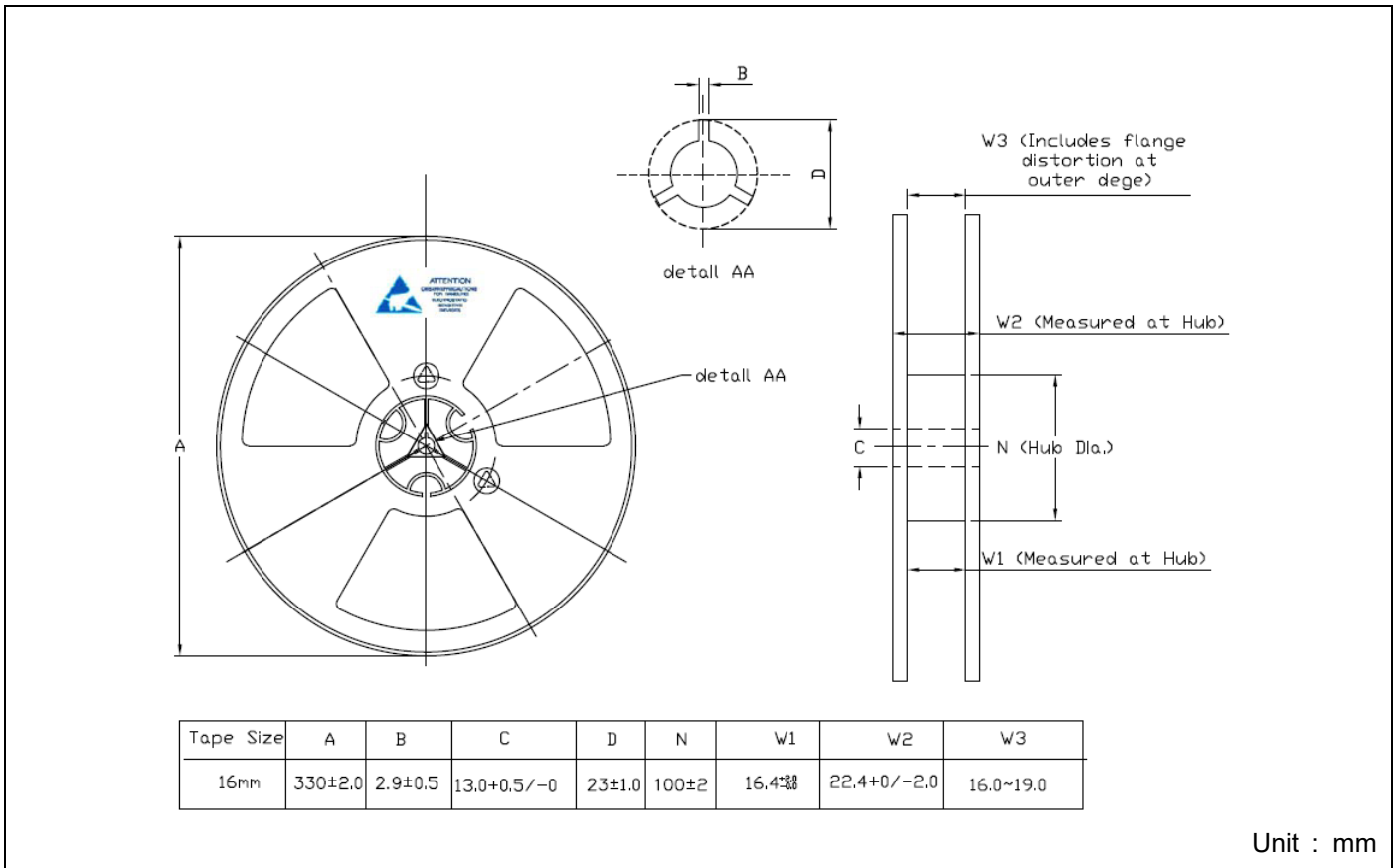

Carrier Tape Dimension

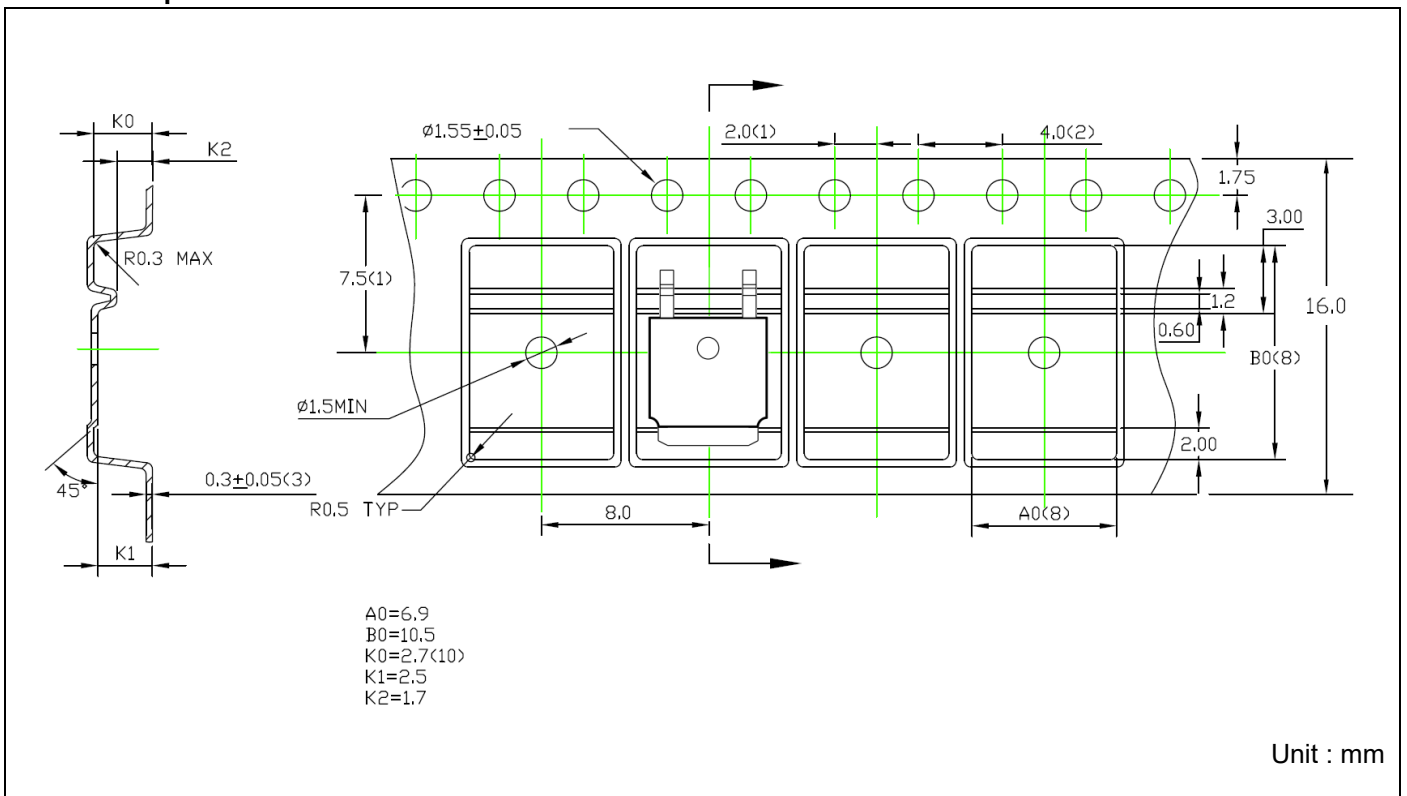

Recommended wave soldering condition

Product	Peak Temperature	Soldering Time
Pb-free devices	260 +0/-5 °C	5 +1/-1 seconds

Recommended temperature profile for IR reflow

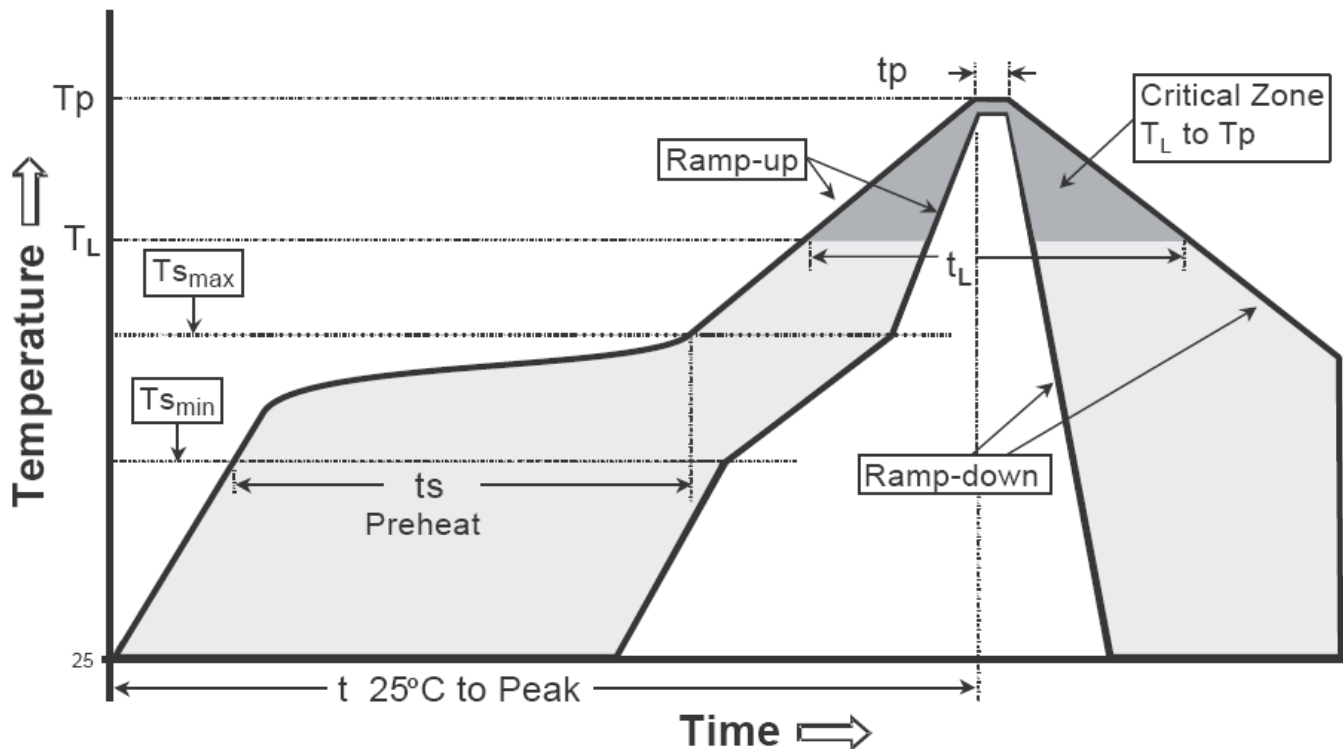

Profile feature	Sn-Pb eutectic Assembly	Pb-free Assembly
Average ramp-up rate (T _{smax} to T _p)	3°C/second max.	3°C/second max.
Preheat		
-Temperature Min(T _{s min})	100°C	150°C
-Temperature Max(T _{s max})	150°C	200°C
-Time(t _{s min} to t _{s max})	60-120 seconds	60-180 seconds
Time maintained above:		
-Temperature (T _L)	183°C	217°C
- Time (t _L)	60-150 seconds	60-150 seconds
Peak Temperature(T _P)	240 +0/-5 °C	260 +0/-5 °C
Time within 5°C of actual peak temperature(tp)	10-30 seconds	20-40 seconds
Ramp down rate	6°C/second max.	6°C/second max.
Time 25 °C to peak temperature	6 minutes max.	8 minutes max.

Note : All temperatures refer to topside of the package, measured on the package body surface.