

1A Snubber Damping Rectifier

QJL3, QJCTL3

Features

- High current capability
- Smoothly soft reverse recovery time (trr)
- Low profile surface mounted package in order to minimize board space
- Pb-free lead plating and halogen-free package

Pinning

Pin	Description	
	QJL3	QJCTL3
1	A	A1
2	K	K1, K2
3	NC	A2
4	K	K1, K2

Outline

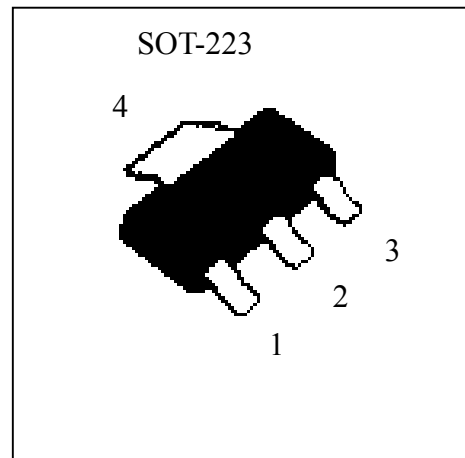

Diode configuration and symbol

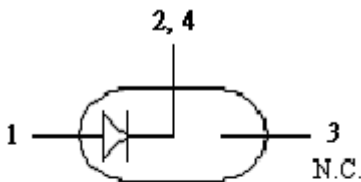

(1) QJL3

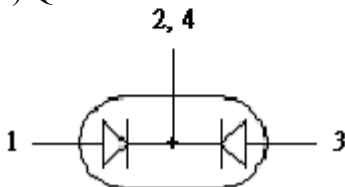

(2) QJCTL3

Marking:

Type	Marking Code
QJL3	QJ
QJCTL3	QJCT



Ordering Information

Device	Package	Shipping
QJL3-XX-T3-G	SOT-223	2500 pcs / Tape & Reel
QJCTL3-XX-T3-G	(Pb-free lead plating and halogen-free package)	

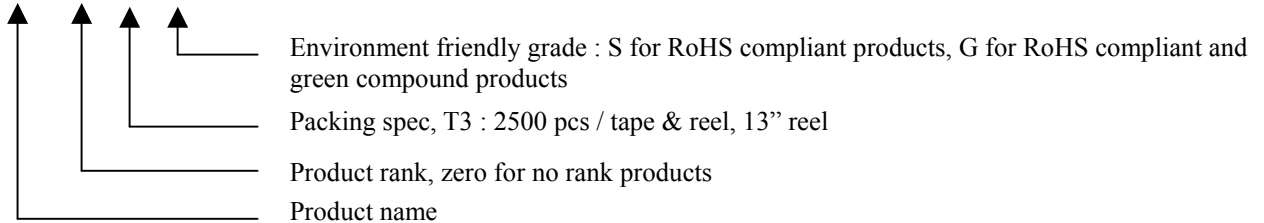

Absolute Maximum Ratings ($T_A=25^{\circ}\text{C}$, unless otherwise noted)

Parameters	Conditions	Symbol	Value		Units
			65	70	
Repetitive peak reverse voltage		V_{RRM}	650	700	V
RMS voltage		V_{RMS}	455	490	V
Continuous reverse voltage		V_R	650	700	V
Forward rectified current	Single phase half wave, 60Hz @ $T_J=25^{\circ}\text{C}$	$I_{F(AV)}$	1		A
Repetitive Peak Forward Current	Single phase half wave, 60Hz @ $T_J=25^{\circ}\text{C}$	I_{FRM}	1.57		A
Forward surge current	8.3ms single half sine-wave superimposed on rated load (JEDEC method)	I_{FSM}	10		A
Power Dissipation		P_D	0.8		W
	(Note 1)		1.2		
	(Note 2)		3		
Maximum reverse recovery time	$I_F=0.5\text{A}$, $I_R=1.0\text{A}$, $I_{RR}=0.25\text{A}$	trr	3		μs
Storage temperature range		Tstg	-55~+150		$^{\circ}\text{C}$
Operating junction temperature range		T_J	-55~+150		$^{\circ}\text{C}$

Thermal Data

Parameter	Symbol	Value	Unit
Thermal Resistance, Junction-to-ambient, max	$R_{th,j-a}$	156	$^{\circ}\text{C/W}$
Thermal Resistance, Junction-to-ambient, max (Note 1)		104	
Thermal Resistance, Junction-to-ambient, max (Note 2)		42	
Thermal Resistance, Junction-to-case, max	$R_{th,j-c}$	35	

Note: *1 When mounted on FR-4 PCB with area measuring $10 \times 10 \times 1$ mm

*2 When mounted on ceramic with area measuring $40 \times 40 \times 1$ mm



Characteristics (T_A=25°C, unless otherwise noted)

Characteristic	Symbol	Condition	Min.	Typ	Max.	Unit
Breakdown Voltage	V _R	I _R =100μA	650	-	-	V
Forward Voltage	V _F 1	I _F =100mA	-	-	0.95	V
	V _F 2	I _F =500mA	-	-	1.2	
Reverse Leakage Current	I _R	V _R =620V	-	-	100	nA
	I _R	V _R =620V, T _A =125°C	-	-	10	μA
Junction Capacitance	C _J	V _R =1V, f=1MHz	-	6	-	pF

Classification by V_R

Rank	65	70
Range	>650V	>700V

Typical Characteristics

Power Derating Curves

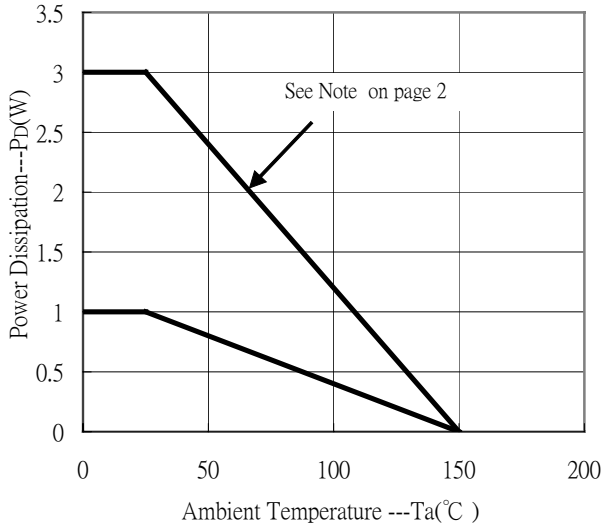

Forward Current vs Forward Voltage

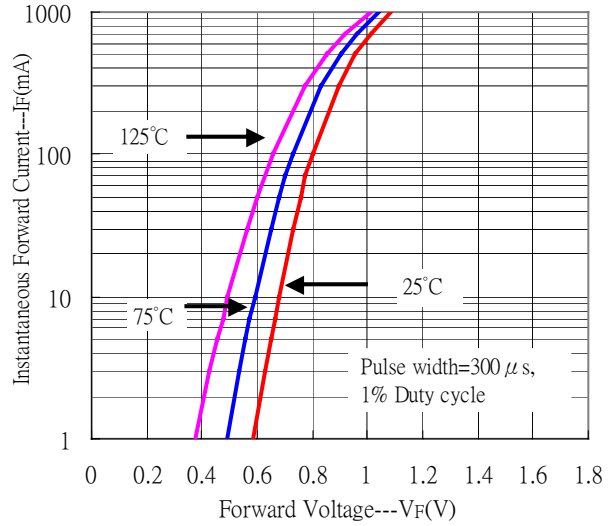

Reverse Leakage Current vs Reverse Voltage

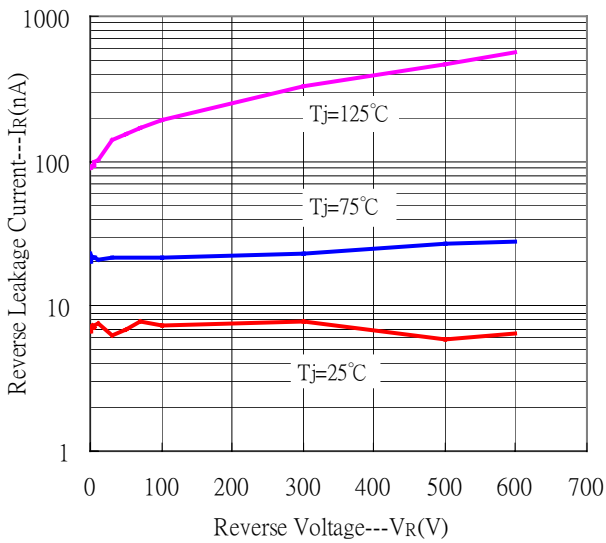

Junction Capacitance vs Reverse Voltage

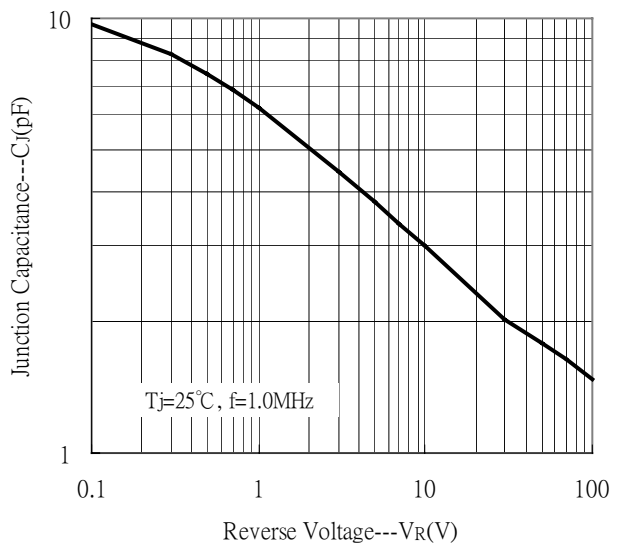

Recommended soldering footprint

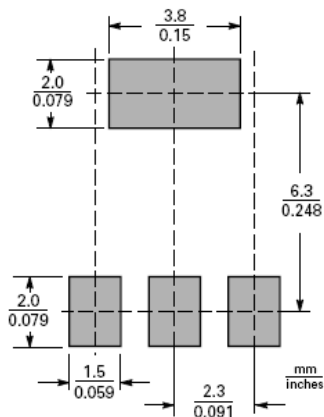

Reel Dimension

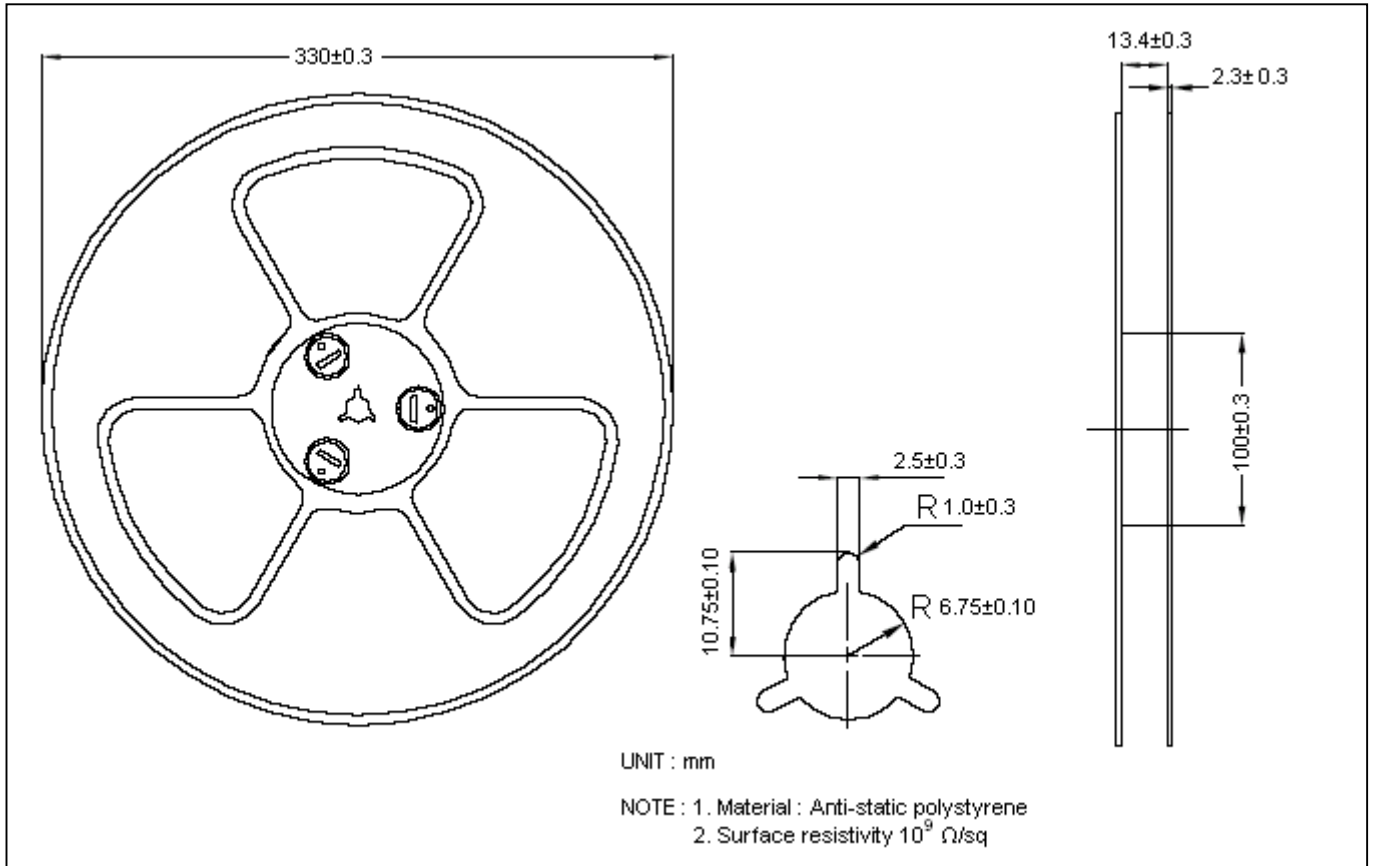

Carrier Tape Dimension

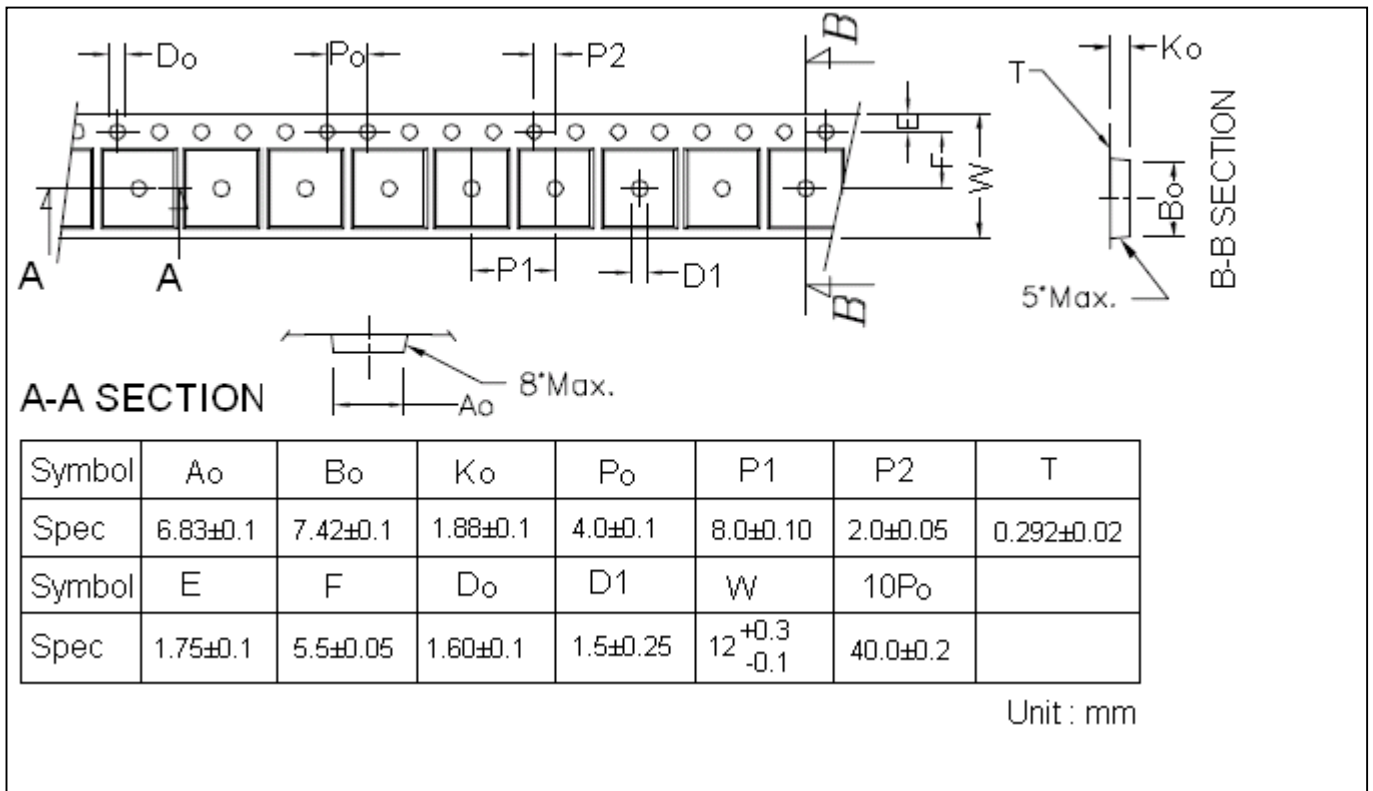

Recommended wave soldering condition

Product	Peak Temperature	Soldering Time
Pb-free devices	260 +0/-5 °C	5 +1/-1 seconds

Recommended temperature profile for IR reflow

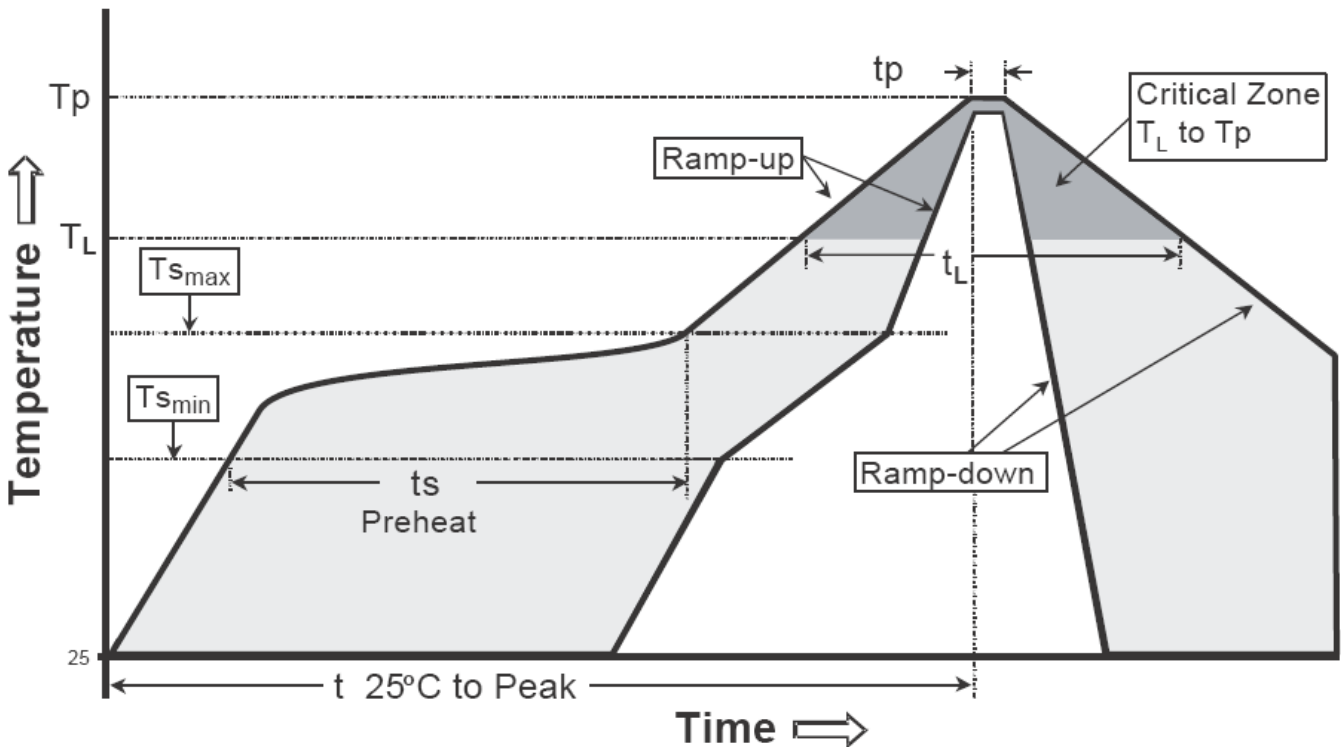

Profile feature	Sn-Pb eutectic Assembly	Pb-free Assembly
Average ramp-up rate (T _{smax} to T _p)	3°C/second max.	3°C/second max.
Preheat		
-Temperature Min(T _{s min})	100°C	150°C
-Temperature Max(T _{s max})	150°C	200°C
-Time(t _{s min} to t _{s max})	60-120 seconds	60-180 seconds
Time maintained above:		
-Temperature (T _L)	183°C	217°C
- Time (t _L)	60-150 seconds	60-150 seconds
Peak Temperature(T _p)	240 +0/-5 °C	260 +0/-5 °C
Time within 5°C of actual peak temperature(tp)	10-30 seconds	20-40 seconds
Ramp down rate	6°C/second max.	6°C/second max.
Time 25 °C to peak temperature	6 minutes max.	8 minutes max.

Note : All temperatures refer to topside of the package, measured on the package body surface.

SOT-223 Dimension

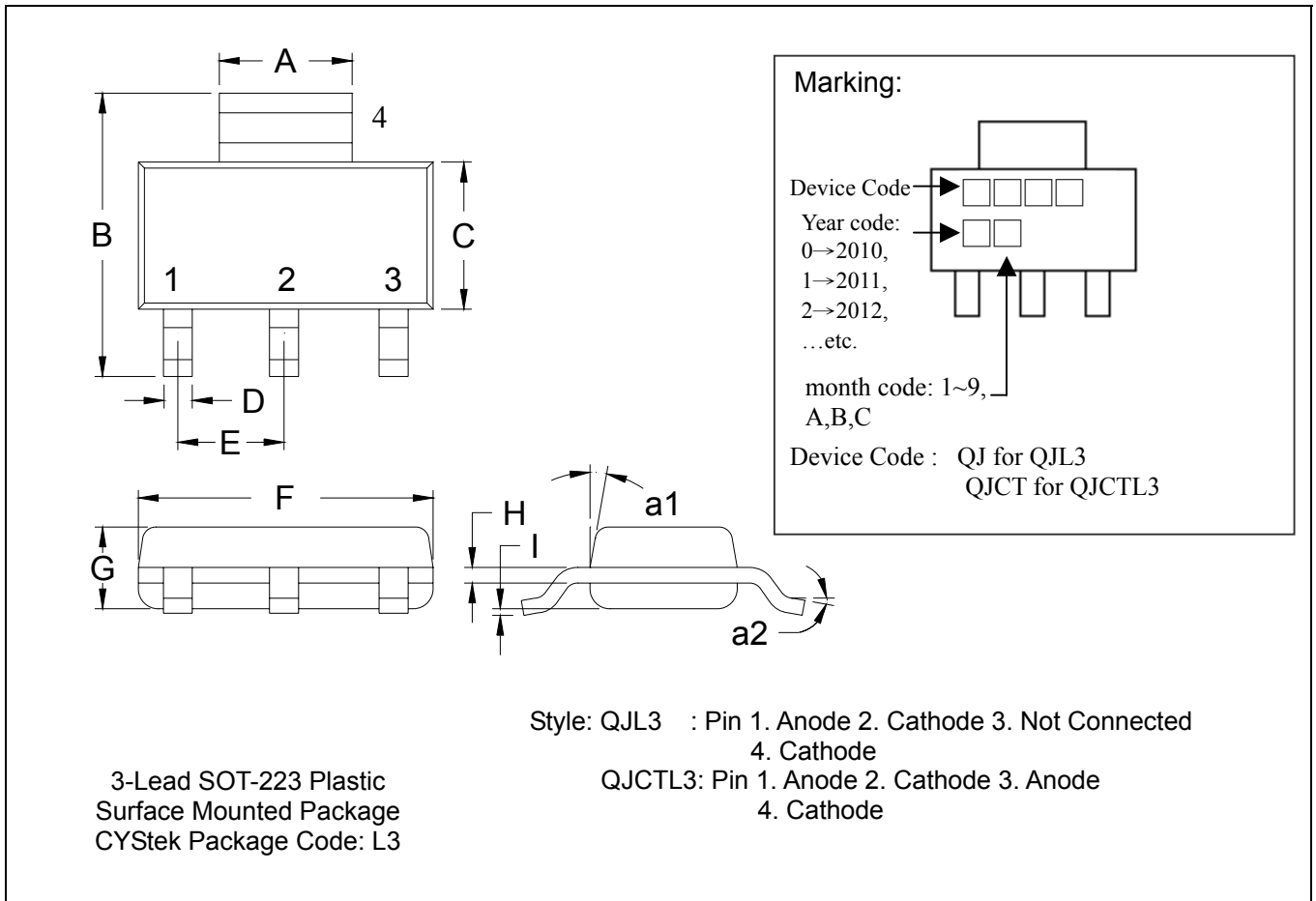

*: Typical

DIM	Inches		Millimeters		DIM	Inches		Millimeters	
	Min.	Max.	Min.	Max.		Min.	Max.	Min.	Max.
A	0.1142	0.1220	2.90	3.10	G	0.0551	0.0709	1.40	1.80
B	0.2638	0.2874	6.70	7.30	H	0.0098	0.0138	0.25	0.35
C	0.1299	0.1457	3.30	3.70	I	0.0008	0.0039	0.02	0.10
D	0.0236	0.0315	0.60	0.80	a1	*13°	-	*13°	-
E	*0.0906	-	*2.30	-	a2	0°	10°	0°	10°
F	0.2480	0.2638	6.30	6.70					

Notes: 1.Controlling dimension: millimeters.
 2.Maximum lead thickness includes lead finish thickness, and minimum lead thickness is the minimum thickness of base material.
 3.If there is any question with packing specification or packing method, please contact your local CYStek sales office.

Material:

- Lead: Pure tin plated.
- Mold Compound: Epoxy resin family, flammability solid burning class: UL94V-0.

Important Notice:

- All rights are reserved. Reproduction in whole or in part is prohibited without the prior written approval of CYStek.
- CYStek reserves the right to make changes to its products without notice.
- CYStek **semiconductor products are not warranted to be suitable for use in Life-Support Applications, or systems.**
- CYStek assumes no liability for any consequence of customer product design, infringement of patents, or application assistance.