

Three Terminal Positive Voltage Regulators

LM78XXE3

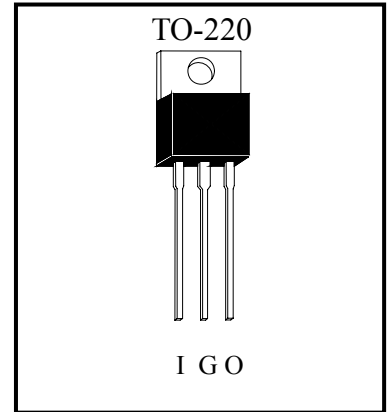

Description

The LM78XXE3 series of fixed voltage monolithic integrated circuit voltage regulators is designed for a wide range of applications. These applications include on-card regulation for elimination of noise and distribution problems associated with single point regulation. Each of these regulators can deliver up to 1.5A of output current. The internal current limiting and thermal shutdown features of these regulators make them essentially immune to overload.

Features:

- 5V, 6V, 8V, 9V, 10V, 12V, 15V, 18V, 24V output voltage available
- Internal Short-Circuit Current Limiting
- High Power Dissipation Capability
- Internal Thermal Overload Protection
- No External Components Required
- Output Transistor Safe Area Compensation
- RoHS compliant package

Absolute Maximum Ratings (Ta=25°C)

| Parameter | | Ratings | Unit |
|--|---------------|------------|------|
| Input Voltage | LM7805~LM7818 | 35 | V |
| | LM7824 | 40 | |
| Output Current | | 1.5 | A |
| Operating Junction Temperature Range | | -40 ~ +125 | °C |
| Storage Temperature Range | | -55 ~ +150 | °C |
| Thermal Resistance, Junction to Ambient (RθJA) | | 65 | °C/W |
| Thermal Resistance, Junction to Case (RθJC) | | 5 | °C/W |

Ordering Information

| Device | Package | Shipping |
|-----------------|--|--|
| LM78XXE3-X-UB-S | TO-220 (Pb-free lead plating package) | 50 pcs/tube, 20 tubes/box, 4 boxes / carton |

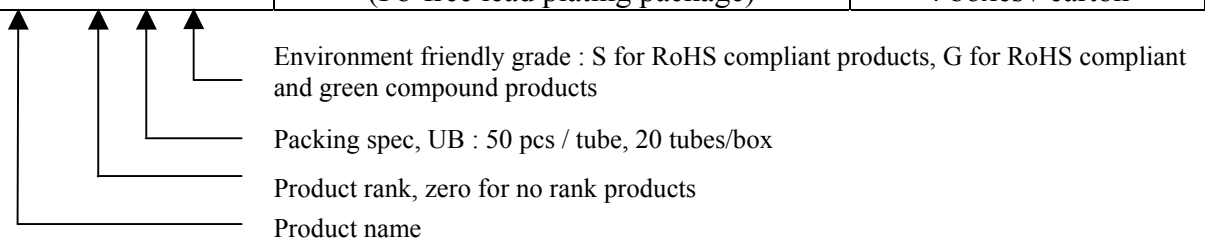

Typical Application

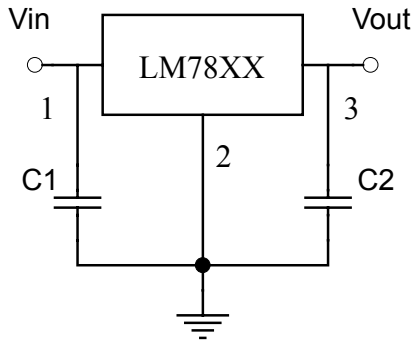

Note:
 C1 and C2 are required if regulator is located far from power supply filter and load, or oscillation may induced on the loop.

Electrical Characteristics

LM7805 ($T_j=0\sim 125^{\circ}\text{C}$, $V_{in}=10\text{V}$, $I_o=500\text{mA}$, $C_{in}=0.33\mu\text{F}$, $C_{out}=0.1\mu\text{F}$, unless otherwise noted)

| Symbol | Parameter | Min | Typ | Max | Conditions | Units |
|-------------------------|------------------------------|------|------|------|--|------------------------------|
| V_o | Output Voltage | 4.85 | 5.0 | 5.15 | $V_{in}=10\text{V}$, $I_o=500\text{mA}$, $T_j=25^{\circ}\text{C}$ $7.5\text{V}\leq V_{in}\leq 20\text{V}$, $5\text{mA}\leq I_o\leq 1\text{A}$, $PD\leq 15\text{W}$ | V |
| | | 4.75 | - | 5.25 | | |
| ΔV_o | Line Regulation | - | 3 | 50 | $7\text{V}\leq V_{in}\leq 25\text{V}$, $T_j=25^{\circ}\text{C}$ | mV |
| | | - | 1 | 25 | $8\text{V}\leq V_{in}\leq 12\text{V}$, $T_j=25^{\circ}\text{C}$ | |
| ΔV_o | Load Regulation | - | - | 100 | $5\text{mA}\leq I_o\leq 1.5\text{A}$, $T_j=25^{\circ}\text{C}$ | mV |
| | | - | - | 50 | $250\text{mA}\leq I_o\leq 750\text{mA}$, $T_j=25^{\circ}\text{C}$ | |
| I_Q | Quiescent Current | - | - | 8 | $V_{in}=10\text{V}$, $I_o=500\text{mA}$, $T_j=25^{\circ}\text{C}$ | mA |
| ΔI_Q | Quiescent Current Change | - | - | 0.5 | $5\text{mA}\leq I_o\leq 1\text{A}$ | mA |
| | | - | - | 1.3 | $7\text{V}\leq V_{in}\leq 25\text{V}$ | |
| V_n | Output Noise Voltage | - | 40 | - | $10\text{Hz}\leq f\leq 100\text{KHz}$, $T_j=25^{\circ}\text{C}$ | μV |
| RR | Ripple Rejection | - | 80 | - | $8\text{V}\leq V_{in}\leq 18\text{V}$, $f=120\text{Hz}$, $T_j=25^{\circ}\text{C}$ | dB |
| VD | Dropout Voltage | - | 2 | - | $I_o=1\text{A}$, $T_j=25^{\circ}\text{C}$ | V |
| ISC | Output Short Circuit Current | - | 250 | - | $V_{in}=35\text{V}$, $T_j=25^{\circ}\text{C}$ | mA |
| IPK | Peak Output Current | - | 1.8 | - | $T_j=25^{\circ}\text{C}$ | A |
| $\Delta V_o/\Delta T_j$ | Temperature Stability | - | -0.6 | - | $I_o=5\text{mA}$, $0^{\circ}\text{C}\leq T_j\leq 125^{\circ}\text{C}$ | $\text{mV}/^{\circ}\text{C}$ |



LM7806 ($T_j=0\sim 125^{\circ}\text{C}$, $V_{in}=11\text{V}$, $I_o=500\text{mA}$, $C_{in}=0.33\mu\text{F}$, $C_{out}=0.1\mu\text{F}$, unless otherwise noted)

| Symbol | Parameter | Min | Typ | Max | Conditions | Units | |
|-------------------------|------------------------------|----------------|------|-----|---|--|---|
| V_o | A-rank(3%) | Output Voltage | 5.82 | 6.0 | 6.18 | $V_{in}=11\text{V}$, $I_o=500\text{mA}$, $T_j=25^{\circ}\text{C}$ $8\text{V}\leq V_{in}\leq 21\text{V}$, $5\text{mA}\leq I_o\leq 1\text{A}$, $PD\leq 15\text{W}$ | V |
| | B-rank(5%) | | 5.70 | - | 6.30 | | |
| ΔV_o | Line Regulation | - | 3 | 60 | $8\text{V}\leq V_{in}\leq 25\text{V}$, $T_j=25^{\circ}\text{C}$ | mV | |
| | | - | 1 | 25 | $9\text{V}\leq V_{in}\leq 13\text{V}$, $T_j=25^{\circ}\text{C}$ | | |
| ΔV_o | Load Regulation | - | - | 100 | $5\text{mA}\leq I_o\leq 1.5\text{A}$, $T_j=25^{\circ}\text{C}$ | mV | |
| | | - | - | 50 | $250\text{mA}\leq I_o\leq 750\text{mA}$, $T_j=25^{\circ}\text{C}$ | | |
| I_Q | Quiescent Current | - | - | 8 | $V_{in}=11\text{V}$, $I_o=500\text{mA}$, $T_j=25^{\circ}\text{C}$ | mA | |
| ΔI_Q | Quiescent Current Change | - | - | 0.5 | $5\text{mA}\leq I_o\leq 1\text{A}$ | mA | |
| | | - | - | 1.3 | $8\text{V}\leq V_{in}\leq 25\text{V}$ | | |
| V_n | Output Noise Voltage | - | 45 | - | $10\text{Hz}\leq f\leq 100\text{KHz}$, $T_j=25^{\circ}\text{C}$ | μV | |
| RR | Ripple Rejection | - | 75 | - | $9\text{V}\leq V_{in}\leq 19\text{V}$, $f=120\text{Hz}$, $T_j=25^{\circ}\text{C}$ | dB | |
| VD | Dropout Voltage | - | 2 | - | $I_o=1\text{A}$, $T_j=25^{\circ}\text{C}$ | V | |
| ISC | Output Short Circuit Current | - | 250 | - | $V_{in}=35\text{V}$, $T_j=25^{\circ}\text{C}$ | mA | |
| IPK | Peak Output Current | - | 1.8 | - | $T_j=25^{\circ}\text{C}$ | A | |
| $\Delta V_o/\Delta T_j$ | Temperature Stability | - | -0.7 | - | $I_o=5\text{mA}$, $0^{\circ}\text{C}\leq T_j\leq 125^{\circ}\text{C}$ | $\text{mV}/^{\circ}\text{C}$ | |

LM7808 ($T_j=0\sim 125^{\circ}\text{C}$, $V_{in}=14\text{V}$, $I_o=500\text{mA}$, $C_{in}=0.33\mu\text{F}$, $C_{out}=0.1\mu\text{F}$, unless otherwise noted)

| Symbol | Parameter | Min | Typ | Max | Conditions | Units | |
|-------------------------|------------------------------|----------------|------|-----|--|---|---|
| V_o | A-rank(3%) | Output Voltage | 7.76 | 8.0 | 8.24 | $V_{in}=14\text{V}$, $I_o=500\text{mA}$, $T_j=25^{\circ}\text{C}$ $10.5\text{V}\leq V_{in}\leq 23\text{V}$, $5\text{mA}\leq I_o\leq 1\text{A}$, $PD\leq 15\text{W}$ | V |
| | B-rank(5%) | | 7.60 | - | 8.40 | | |
| ΔV_o | Line Regulation | - | 3 | 80 | $10.5\text{V}\leq V_{in}\leq 25\text{V}$, $T_j=25^{\circ}\text{C}$ | mV | |
| | | - | 1 | 40 | $11\text{V}\leq V_{in}\leq 17\text{V}$, $T_j=25^{\circ}\text{C}$ | | |
| ΔV_o | Load Regulation | - | - | 100 | $5\text{mA}\leq I_o\leq 1.5\text{A}$, $T_j=25^{\circ}\text{C}$ | mV | |
| | | - | - | 50 | $250\text{mA}\leq I_o\leq 750\text{mA}$, $T_j=25^{\circ}\text{C}$ | | |
| I_Q | Quiescent Current | - | - | 8 | $V_{in}=14\text{V}$, $I_o=500\text{mA}$, $T_j=25^{\circ}\text{C}$ | mA | |
| ΔI_Q | Quiescent Current Change | - | - | 0.5 | $5\text{mA}\leq I_o\leq 1\text{A}$ | mA | |
| | | - | - | 1.3 | $10.5\text{V}\leq V_{in}\leq 25\text{V}$ | | |
| V_n | Output Noise Voltage | - | 58 | - | $10\text{Hz}\leq f\leq 100\text{KHz}$, $T_j=25^{\circ}\text{C}$ | μV | |
| RR | Ripple Rejection | - | 72 | - | $11.5\text{V}\leq V_{in}\leq 21.5\text{V}$, $f=120\text{Hz}$, $T_j=25^{\circ}\text{C}$ | dB | |
| VD | Dropout Voltage | - | 2 | - | $I_o=1\text{A}$, $T_j=25^{\circ}\text{C}$ | V | |
| ISC | Output Short Circuit Current | - | 250 | - | $V_{in}=35\text{V}$, $T_j=25^{\circ}\text{C}$ | mA | |
| IPK | Peak Output Current | - | 1.8 | - | $T_j=25^{\circ}\text{C}$ | A | |
| $\Delta V_o/\Delta T_j$ | Temperature Stability | - | -0.9 | - | $I_o=5\text{mA}$, $0^{\circ}\text{C}\leq T_j\leq 125^{\circ}\text{C}$ | $\text{mV}/^{\circ}\text{C}$ | |



LM7809 ($T_j=0\sim 125^\circ\text{C}$, $V_{in}=15\text{V}$, $I_o=500\text{mA}$, $C_{in}=0.33\mu\text{F}$, $C_{out}=0.1\mu\text{F}$, unless otherwise noted)

| Symbol | Parameter | Min | Typ | Max | Conditions | Units | |
|-------------------------|------------------------------|----------------|------|-----|--|---|---|
| V_o | A-rank(3%) | Output Voltage | 8.73 | 9.0 | 9.27 | $V_{in}=15\text{V}$, $I_o=500\text{mA}$, $T_j=25^\circ\text{C}$ $11.5\text{V}\leq V_{in}\leq 24\text{V}$, $5\text{mA}\leq I_o\leq 1\text{A}$, $PD\leq 15\text{W}$ | V |
| | B-rank(5%) | | 8.55 | - | 9.45 | | |
| ΔV_o | Line Regulation | - | 5 | 90 | $11.5\text{V}\leq V_{in}\leq 25\text{V}$, $T_j=25^\circ\text{C}$ | mV | |
| | | - | 3 | 45 | $13\text{V}\leq V_{in}\leq 19\text{V}$, $T_j=25^\circ\text{C}$ | | |
| ΔV_o | Load Regulation | - | - | 100 | $5\text{mA}\leq I_o\leq 1.5\text{A}$, $T_j=25^\circ\text{C}$ | mV | |
| | | - | - | 50 | $250\text{mA}\leq I_o\leq 750\text{mA}$, $T_j=25^\circ\text{C}$ | | |
| I_Q | Quiescent Current | - | - | 8 | $V_{in}=15\text{V}$, $I_o=500\text{mA}$, $T_j=25^\circ\text{C}$ | mA | |
| ΔI_Q | Quiescent Current Change | - | - | 0.5 | $5\text{mA}\leq I_o\leq 1\text{A}$ | mA | |
| | | - | - | 1.3 | $11.5\text{V}\leq V_{in}\leq 26\text{V}$ | | |
| V_n | Output Noise Voltage | - | 58 | - | $10\text{Hz}\leq f\leq 100\text{KHz}$, $T_j=25^\circ\text{C}$ | μV | |
| RR | Ripple Rejection | - | 72 | - | $12.5\text{V}\leq V_{in}\leq 22.5\text{V}$, $f=120\text{Hz}$, $T_j=25^\circ\text{C}$ | dB | |
| VD | Dropout Voltage | - | 2 | - | $I_o=1\text{A}$, $T_j=25^\circ\text{C}$ | V | |
| ISC | Output Short Circuit Current | - | 250 | - | $V_{in}=35\text{V}$, $T_j=25^\circ\text{C}$ | mA | |
| IPK | Peak Output Current | - | 1.8 | - | $T_j=25^\circ\text{C}$ | A | |
| $\Delta V_o/\Delta T_j$ | Temperature Stability | - | -1.1 | - | $I_o=5\text{mA}$, $0^\circ\text{C}\leq T_j\leq 125^\circ\text{C}$ | $\text{mV}/^\circ\text{C}$ | |

LM7810 ($T_j=0\sim 125^\circ\text{C}$, $V_{in}=16\text{V}$, $I_o=500\text{mA}$, $C_{in}=0.33\mu\text{F}$, $C_{out}=0.1\mu\text{F}$, unless otherwise noted)

| Symbol | Parameter | Min | Typ | Max | Conditions | Units | |
|-------------------------|------------------------------|----------------|------|------|--|---|---|
| V_o | A-rank(3%) | Output Voltage | 9.70 | 10.0 | 10.30 | $V_{in}=16\text{V}$, $I_o=500\text{mA}$, $T_j=25^\circ\text{C}$ $12.5\text{V}\leq V_{in}\leq 25\text{V}$, $5\text{mA}\leq I_o\leq 1\text{A}$, $PD\leq 15\text{W}$ | V |
| | B-rank(5%) | | 9.50 | - | 10.50 | | |
| ΔV_o | Line Regulation | - | - | 100 | $13\text{V}\leq V_{in}\leq 25\text{V}$, $T_j=25^\circ\text{C}$ | mV | |
| | | - | - | 50 | $14\text{V}\leq V_{in}\leq 20\text{V}$, $T_j=25^\circ\text{C}$ | | |
| ΔV_o | Load Regulation | - | - | 100 | $5\text{mA}\leq I_o\leq 1.5\text{A}$, $T_j=25^\circ\text{C}$ | mV | |
| | | - | - | 50 | $250\text{mA}\leq I_o\leq 750\text{mA}$, $T_j=25^\circ\text{C}$ | | |
| I_Q | Quiescent Current | - | - | 8 | $V_{in}=16\text{V}$, $I_o=500\text{mA}$, $T_j=25^\circ\text{C}$ | mA | |
| ΔI_Q | Quiescent Current Change | - | - | 0.5 | $5\text{mA}\leq I_o\leq 1\text{A}$ | mA | |
| | | - | - | 1.0 | $12.5\text{V}\leq V_{in}\leq 25\text{V}$ | | |
| V_n | Output Noise Voltage | - | 58 | - | $10\text{Hz}\leq f\leq 100\text{KHz}$, $T_j=25^\circ\text{C}$ | μV | |
| RR | Ripple Rejection | - | 72 | - | $13\text{V}\leq V_{in}\leq 23\text{V}$, $f=120\text{Hz}$, $T_j=25^\circ\text{C}$ | dB | |
| VD | Dropout Voltage | - | 2 | - | $I_o=1\text{A}$, $T_j=25^\circ\text{C}$ | V | |
| ISC | Output Short Circuit Current | - | 250 | - | $V_{in}=35\text{V}$, $T_j=25^\circ\text{C}$ | mA | |
| IPK | Peak Output Current | - | 1.8 | - | $T_j=25^\circ\text{C}$ | A | |
| $\Delta V_o/\Delta T_j$ | Temperature Stability | - | -1.1 | - | $I_o=5\text{mA}$, $0^\circ\text{C}\leq T_j\leq 125^\circ\text{C}$ | $\text{mV}/^\circ\text{C}$ | |



LM7812 ($T_j=0\sim 125^{\circ}\text{C}$, $V_{in}=19\text{V}$, $I_o=500\text{mA}$, $C_{in}=0.33\mu\text{F}$, $C_{out}=0.1\mu\text{F}$, unless otherwise noted)

| Symbol | Parameter | Min | Typ | Max | Conditions | Units | |
|-------------------------|------------------------------|----------------|-------|------|--|---|---|
| V_o | A-rank(3%) | Output Voltage | 11.64 | 12.0 | 12.36 | $V_{in}=19\text{V}$, $I_o=500\text{mA}$, $T_j=25^{\circ}\text{C}$ $14.5\text{V}\leq V_{in}\leq 27\text{V}$, $5\text{mA}\leq I_o\leq 1\text{A}$, $PD\leq 15\text{W}$ | V |
| | B-rank(5%) | | 11.40 | - | 12.60 | | |
| ΔV_o | Line Regulation | - | 10 | 120 | $14.5\text{V}\leq V_{in}\leq 30\text{V}$, $T_j=25^{\circ}\text{C}$ | mV | |
| | | - | 3 | 60 | $16\text{V}\leq V_{in}\leq 22\text{V}$, $T_j=25^{\circ}\text{C}$ | | |
| ΔV_o | Load Regulation | - | - | 100 | $5\text{mA}\leq I_o\leq 1.5\text{A}$, $T_j=25^{\circ}\text{C}$ | mV | |
| | | - | - | 60 | $250\text{mA}\leq I_o\leq 750\text{mA}$, $T_j=25^{\circ}\text{C}$ | | |
| I_Q | Quiescent Current | - | - | 8 | $V_{in}=19\text{V}$, $I_o=500\text{mA}$, $T_j=25^{\circ}\text{C}$ | mA | |
| ΔI_Q | Quiescent Current Change | - | - | 0.5 | $5\text{mA}\leq I_o\leq 1\text{A}$ | mA | |
| | | - | - | 1.3 | $14.5\text{V}\leq V_{in}\leq 30\text{V}$ | | |
| V_n | Output Noise Voltage | - | 75 | - | $10\text{Hz}\leq f\leq 100\text{KHz}$, $T_j=25^{\circ}\text{C}$ | μV | |
| RR | Ripple Rejection | - | 72 | - | $15\text{V}\leq V_{in}\leq 25\text{V}$, $f=120\text{Hz}$, $T_j=25^{\circ}\text{C}$ | dB | |
| VD | Dropout Voltage | - | 2 | - | $I_o=1\text{A}$, $T_j=25^{\circ}\text{C}$ | V | |
| ISC | Output Short Circuit Current | - | 250 | - | $V_{in}=35\text{V}$, $T_j=25^{\circ}\text{C}$ | mA | |
| IPK | Peak Output Current | - | 1.8 | - | $T_j=25^{\circ}\text{C}$ | A | |
| $\Delta V_o/\Delta T_j$ | Temperature Stability | - | -1.5 | - | $I_o=5\text{mA}$, $0^{\circ}\text{C}\leq T_j\leq 125^{\circ}\text{C}$ | $\text{mV}/^{\circ}\text{C}$ | |

LM7815 ($T_j=0\sim 125^{\circ}\text{C}$, $V_{in}=23\text{V}$, $I_o=500\text{mA}$, $C_{in}=0.33\mu\text{F}$, $C_{out}=0.1\mu\text{F}$, unless otherwise noted)

| Symbol | Parameter | Min | Typ | Max | Conditions | Units | |
|-------------------------|------------------------------|----------------|-------|------|--|---|---|
| V_o | A-rank(3%) | Output Voltage | 14.55 | 15.0 | 15.45 | $V_{in}=23\text{V}$, $I_o=500\text{mA}$, $T_j=25^{\circ}\text{C}$ $17.5\text{V}\leq V_{in}\leq 30\text{V}$, $5\text{mA}\leq I_o\leq 1\text{A}$, $PD\leq 15\text{W}$ | V |
| | B-rank(5%) | | 14.25 | - | 15.75 | | |
| ΔV_o | Line Regulation | - | - | 150 | $17.5\text{V}\leq V_{in}\leq 30\text{V}$, $T_j=25^{\circ}\text{C}$ | mV | |
| | | - | - | 75 | $18.5\text{V}\leq V_{in}\leq 30\text{V}$, $T_j=25^{\circ}\text{C}$ | | |
| ΔV_o | Load Regulation | - | - | 150 | $5\text{mA}\leq I_o\leq 1.5\text{A}$, $T_j=25^{\circ}\text{C}$ | mV | |
| | | - | - | 75 | $250\text{mA}\leq I_o\leq 750\text{mA}$, $T_j=25^{\circ}\text{C}$ | | |
| I_Q | Quiescent Current | - | - | 8 | $V_{in}=23\text{V}$, $I_o=500\text{mA}$, $T_j=25^{\circ}\text{C}$ | mA | |
| ΔI_Q | Quiescent Current Change | - | - | 0.5 | $5\text{mA}\leq I_o\leq 1\text{A}$ | mA | |
| | | - | - | 1.3 | $17.5\text{V}\leq V_{in}\leq 30\text{V}$ | | |
| V_n | Output Noise Voltage | - | 90 | - | $10\text{Hz}\leq f\leq 100\text{KHz}$, $T_j=25^{\circ}\text{C}$ | μV | |
| RR | Ripple Rejection | - | 70 | - | $18.5\text{V}\leq V_{in}\leq 28.5\text{V}$, $f=120\text{Hz}$, $T_j=25^{\circ}\text{C}$ | dB | |
| VD | Dropout Voltage | - | 2 | - | $I_o=1\text{A}$, $T_j=25^{\circ}\text{C}$ | V | |
| ISC | Output Short Circuit Current | - | 250 | - | $V_{in}=35\text{V}$, $T_j=25^{\circ}\text{C}$ | mA | |
| IPK | Peak Output Current | - | 1.8 | - | $T_j=25^{\circ}\text{C}$ | A | |
| $\Delta V_o/\Delta T_j$ | Temperature Stability | - | -1.8 | - | $I_o=5\text{mA}$, $0^{\circ}\text{C}\leq T_j\leq 125^{\circ}\text{C}$ | $\text{mV}/^{\circ}\text{C}$ | |



LM7818 ($T_j=0\sim 125^{\circ}\text{C}$, $V_{in}=27\text{V}$, $I_o=500\text{mA}$, $C_{in}=0.33\mu\text{F}$, $C_{out}=0.1\mu\text{F}$, unless otherwise noted)

| Symbol | Parameter | Min | Typ | Max | Conditions | Units | |
|-------------------------|------------------------------|----------------|-------|------|--|---|---|
| V_o | A-rank(3%) | Output Voltage | 17.46 | 18.0 | 18.54 | $V_{in}=27\text{V}$, $I_o=500\text{mA}$, $T_j=25^{\circ}\text{C}$ $21\text{V}\leq V_{in}\leq 33\text{V}$, $5\text{mA}\leq I_o\leq 1\text{A}$, $PD\leq 15\text{W}$ | V |
| | B-rank(5%) | | 17.10 | - | 18.90 | | |
| ΔV_o | Line Regulation | - | - | 180 | $21\text{V}\leq V_{in}\leq 33\text{V}$, $T_j=25^{\circ}\text{C}$ | mV | |
| | | - | - | 90 | $24\text{V}\leq V_{in}\leq 30\text{V}$, $T_j=25^{\circ}\text{C}$ | | |
| ΔV_o | Load Regulation | - | - | 180 | $5\text{mA}\leq I_o\leq 1.5\text{A}$, $T_j=25^{\circ}\text{C}$ | mV | |
| | | - | - | 90 | $250\text{mA}\leq I_o\leq 750\text{mA}$, $T_j=25^{\circ}\text{C}$ | | |
| I_Q | Quiescent Current | - | - | 8 | $V_{in}=27\text{V}$, $I_o=500\text{mA}$, $T_j=25^{\circ}\text{C}$ | mA | |
| ΔI_Q | Quiescent Current Change | - | - | 0.5 | $5\text{mA}\leq I_o\leq 1\text{A}$ | mA | |
| | | - | - | 1.0 | $21\text{V}\leq V_{in}\leq 33\text{V}$ | | |
| V_n | Output Noise Voltage | - | 110 | - | $10\text{Hz}\leq f\leq 100\text{KHz}$, $T_j=25^{\circ}\text{C}$ | μV | |
| RR | Ripple Rejection | - | 69 | - | $22\text{V}\leq V_{in}\leq 32\text{V}$, $f=120\text{Hz}$, $T_j=25^{\circ}\text{C}$ | dB | |
| VD | Dropout Voltage | - | 2 | - | $I_o=1\text{A}$, $T_j=25^{\circ}\text{C}$ | V | |
| ISC | Output Short Circuit Current | - | 250 | - | $V_{in}=35\text{V}$, $T_j=25^{\circ}\text{C}$ | mA | |
| IPK | Peak Output Current | - | 1.8 | - | $T_j=25^{\circ}\text{C}$ | A | |
| $\Delta V_o/\Delta T_j$ | Temperature Stability | - | -2.2 | - | $I_o=5\text{mA}$, $0^{\circ}\text{C}\leq T_j\leq 125^{\circ}\text{C}$ | $\text{mV}/^{\circ}\text{C}$ | |

LM7824 ($T_j=0\sim 125^{\circ}\text{C}$, $V_{in}=33\text{V}$, $I_o=500\text{mA}$, $C_{in}=0.33\mu\text{F}$, $C_{out}=0.1\mu\text{F}$, unless otherwise noted)

| Symbol | Parameter | Min | Typ | Max | Conditions | Units | |
|-------------------------|------------------------------|----------------|-------|------|--|---|---|
| V_o | A-rank(3%) | Output Voltage | 23.28 | 24.0 | 24.72 | $V_{in}=33\text{V}$, $I_o=500\text{mA}$, $T_j=25^{\circ}\text{C}$ $27\text{V}\leq V_{in}\leq 38\text{V}$, $5\text{mA}\leq I_o\leq 1\text{A}$, $PD\leq 15\text{W}$ | V |
| | B-rank(5%) | | 22.80 | - | 25.20 | | |
| ΔV_o | Line Regulation | - | - | 240 | $27\text{V}\leq V_{in}\leq 38\text{V}$, $T_j=25^{\circ}\text{C}$ | mV | |
| | | - | - | 120 | $30\text{V}\leq V_{in}\leq 36\text{V}$, $T_j=25^{\circ}\text{C}$ | | |
| ΔV_o | Load Regulation | - | - | 240 | $5\text{mA}\leq I_o\leq 1.5\text{A}$, $T_j=25^{\circ}\text{C}$ | mV | |
| | | - | - | 120 | $250\text{mA}\leq I_o\leq 750\text{mA}$, $T_j=25^{\circ}\text{C}$ | | |
| I_Q | Quiescent Current | - | - | 8 | $V_{in}=33\text{V}$, $I_o=500\text{mA}$, $T_j=25^{\circ}\text{C}$ | mA | |
| ΔI_Q | Quiescent Current Change | - | - | 0.5 | $5\text{mA}\leq I_o\leq 1\text{A}$ | mA | |
| | | - | - | 1.0 | $28\text{V}\leq V_{in}\leq 38\text{V}$ | | |
| V_n | Output Noise Voltage | - | 170 | - | $10\text{Hz}\leq f\leq 100\text{KHz}$, $T_j=25^{\circ}\text{C}$ | μV | |
| RR | Ripple Rejection | - | 66 | - | $28\text{V}\leq V_{in}\leq 38\text{V}$, $f=120\text{Hz}$, $T_j=25^{\circ}\text{C}$ | dB | |
| VD | Dropout Voltage | - | 2 | - | $I_o=1\text{A}$, $T_j=25^{\circ}\text{C}$ | V | |
| ISC | Output Short Circuit Current | - | 250 | - | $V_{in}=35\text{V}$, $T_j=25^{\circ}\text{C}$ | mA | |
| IPK | Peak Output Current | - | 1.8 | - | $T_j=25^{\circ}\text{C}$ | A | |
| $\Delta V_o/\Delta T_j$ | Temperature Stability | - | -2.8 | - | $I_o=5\text{mA}$, $0^{\circ}\text{C}\leq T_j\leq 125^{\circ}\text{C}$ | $\text{mV}/^{\circ}\text{C}$ | |

Characteristic Curves

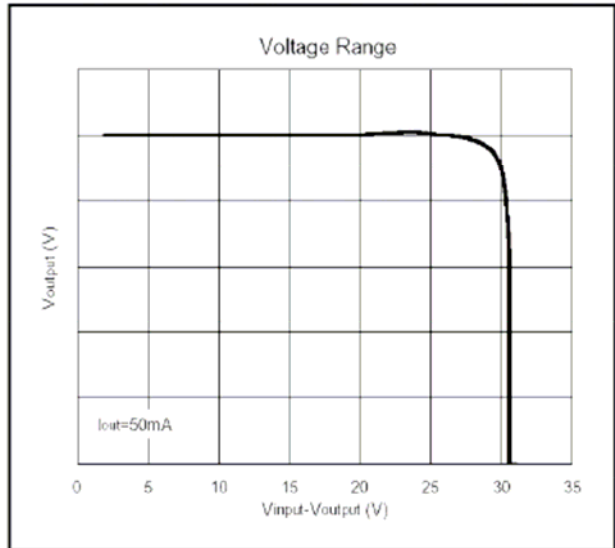
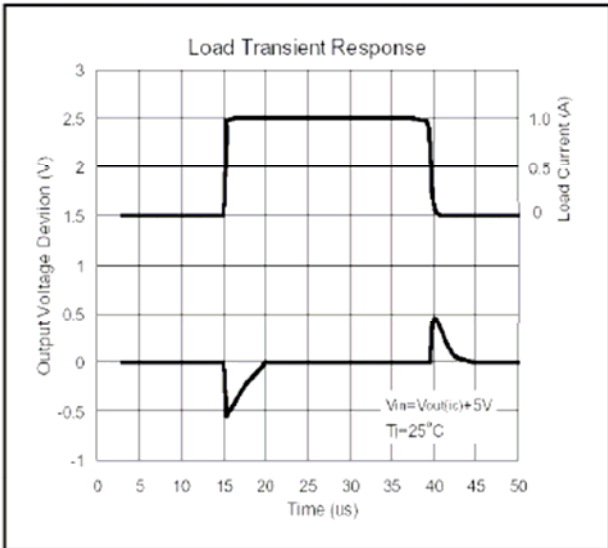
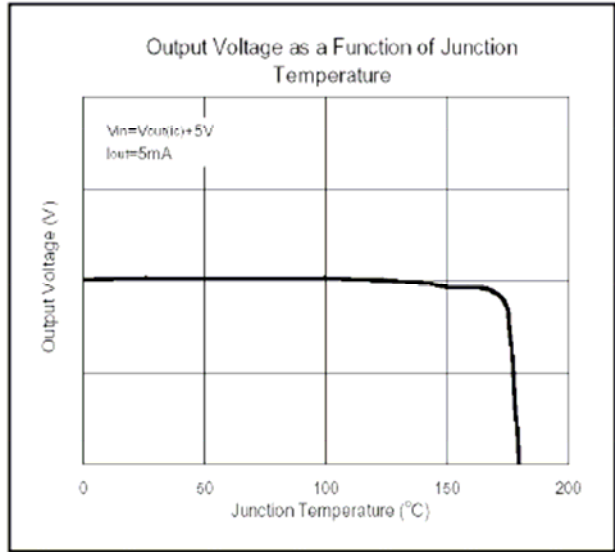
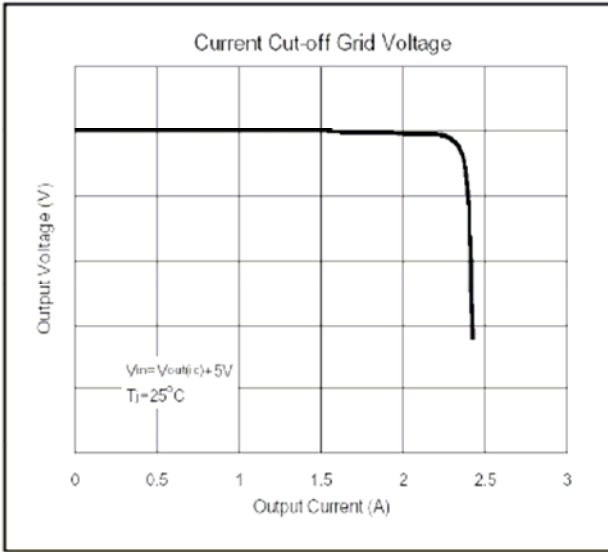

Recommended wave soldering condition

| | | |
|-----------------|------------------|-----------------|
| Product | Peak Temperature | Soldering Time |
| Pb-free devices | 260 +0/-5 °C | 5 +1/-1 seconds |

Recommended temperature profile for IR reflow

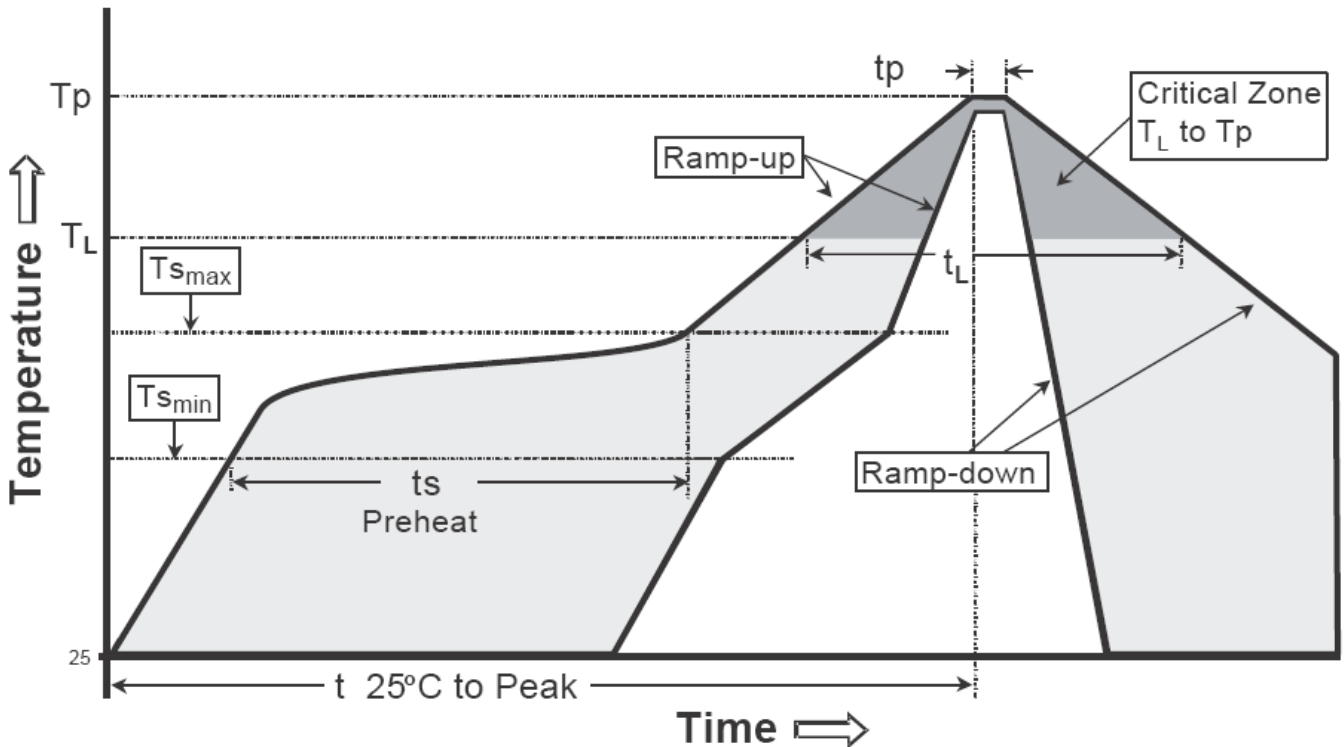

| Profile feature | Sn-Pb eutectic Assembly | Pb-free Assembly |
|---|-------------------------|------------------|
| Average ramp-up rate (T _{smax} to T _p) | 3°C/second max. | 3°C/second max. |
| Preheat | | |
| -Temperature Min(T _{s min}) | 100°C | 150°C |
| -Temperature Max(T _{s max}) | 150°C | 200°C |
| -Time(t _{s min} to t _{s max}) | 60-120 seconds | 60-180 seconds |
| Time maintained above: | | |
| -Temperature (T _L) | 183°C | 217°C |
| - Time (t _L) | 60-150 seconds | 60-150 seconds |
| Peak Temperature(T _P) | 240 +0/-5 °C | 260 +0/-5 °C |
| Time within 5°C of actual peak temperature(tp) | 10-30 seconds | 20-40 seconds |
| Ramp down rate | 6°C/second max. | 6°C/second max. |
| Time 25 °C to peak temperature | 6 minutes max. | 8 minutes max. |

Note : All temperatures refer to topside of the package, measured on the package body surface.

TO-220 Dimension

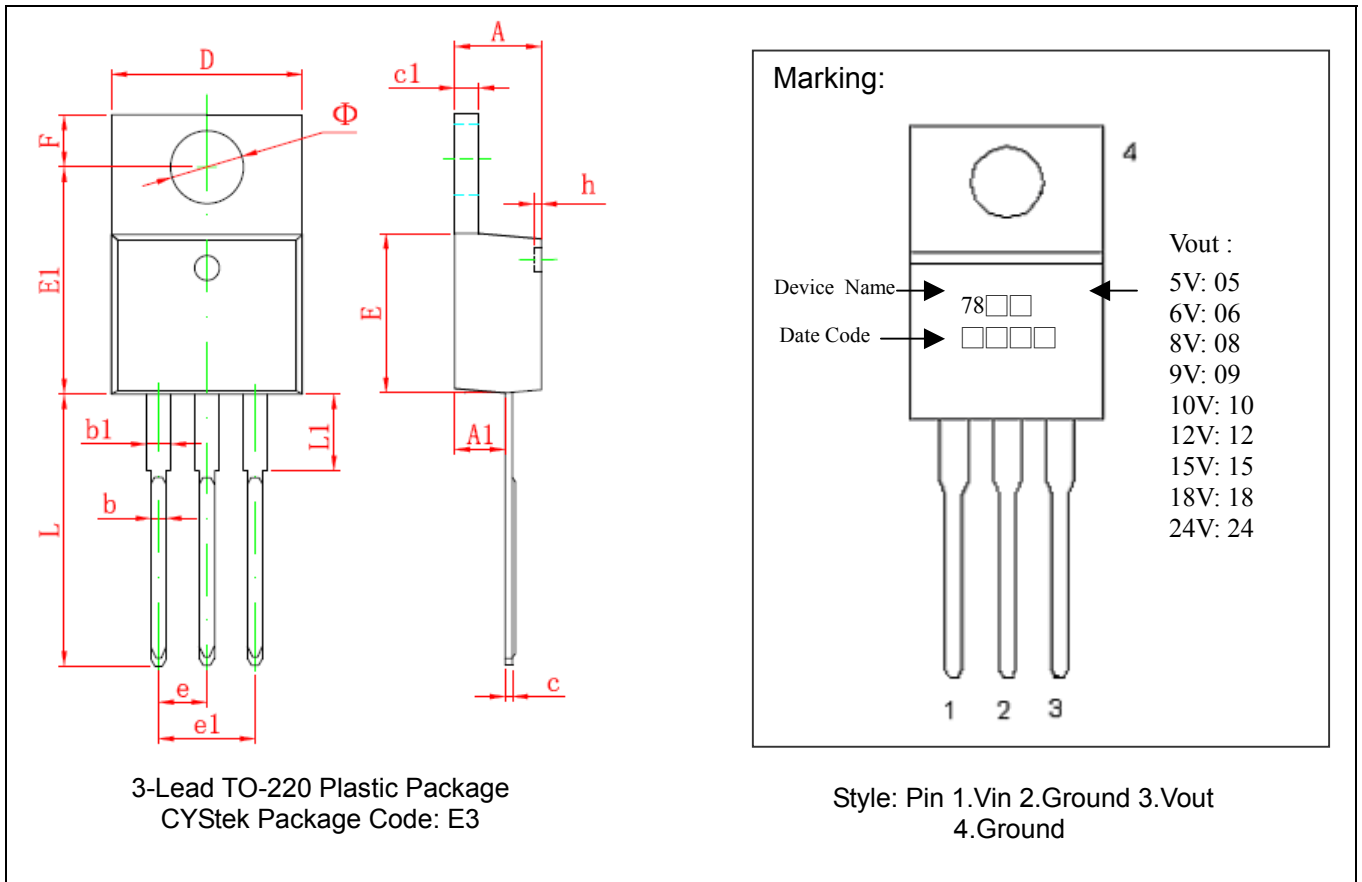

*: Typical

| DIM | Millimeters | | Inches | | DIM | Millimeters | | Inches | |
|-----|-------------|--------|--------|-------|-----|-------------|--------|--------|-------|
| | Min. | Max. | Min. | Max. | | Min. | Max. | Min. | Max. |
| A | 4.470 | 4.670 | 0.176 | 0.184 | E1 | 12.060 | 12.460 | 0.475 | 0.491 |
| A1 | 2.520 | 2.820 | 0.099 | 0.111 | e | 2.540* | | 0.100* | |
| b | 0.710 | 0.910 | 0.028 | 0.036 | e1 | 4.980 | 5.180 | 0.196 | 0.204 |
| b1 | 1.170 | 1.370 | 0.046 | 0.054 | F | 2.590 | 2.890 | 0.102 | 0.114 |
| c | 0.310 | 0.530 | 0.012 | 0.021 | h | 0.000 | 0.300 | 0.000 | 0.012 |
| c1 | 1.170 | 1.370 | 0.046 | 0.054 | L | 13.400 | 13.800 | 0.528 | 0.543 |
| D | 10.010 | 10.310 | 0.394 | 0.406 | L1 | 3.560 | 3.960 | 0.140 | 0.156 |
| E | 8.500 | 8.900 | 0.335 | 0.350 | Φ | 3.735 | 3.935 | 0.147 | 0.155 |

Notes: 1.Controlling dimension: millimeters.
 2.Maximum lead thickness includes lead finish thickness, and minimum lead thickness is the minimum thickness of base material.
 3.If there is any question with packing specification or packing method, please contact your local CYStek sales office.

Material:

- Lead: Pure tin plated.
- Mold Compound: Epoxy resin family, flammability solid burning class: UL94V-0.

Important Notice:

- All rights are reserved. Reproduction in whole or in part is prohibited without the prior written approval of CYStek.
- CYStek reserves the right to make changes to its products without notice.
- CYStek **semiconductor products are not warranted to be suitable for use in Life-Support Applications, or systems.**
- CYStek assumes no liability for any consequence of customer product design, infringement of patents, or application assistance.