

Small Signal Schottky (double) diodes

BAR40S3/BAR40AS3

BAR40CS3/BAR40SS3

Description

Planar silicon Schottky barrier diodes encapsulated in a SOT-323 small plastic SMD package. Single diodes and double diodes with different pinning are available.

Features

- Very small conduction losses
- Low forward voltage drop
- Small plastic SMD package
- Pb-free lead plating and halogen-free package

Applications

- Ultra high-speed switching
- Voltage clamping
- Protection circuits
- Blocking diodes

Pinning

Pin	Description			
	BAR40	BAR40A	BAR40C	BAR40S
1	A	K1	A1	A1
2	NC	K2	A2	K2
3	K	A1,A2	K1,K2	K1,A1

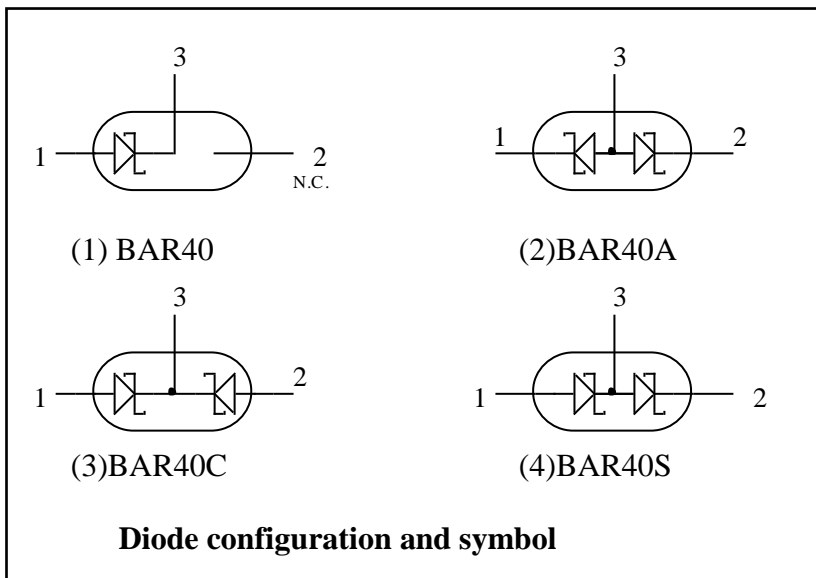

Outline

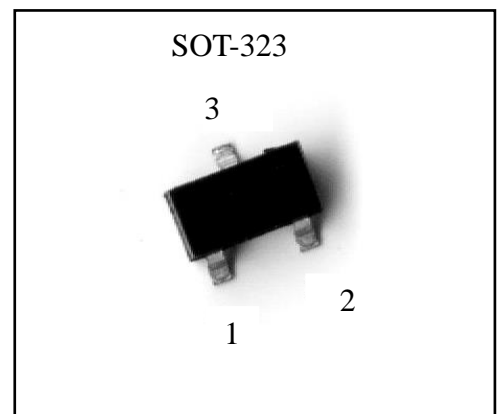

Marking:

Type	Marking Code
BAR40 S3	B4
BAR40AS3	B7
BAR40CS3	5C
BAR40SS3	B8



Absolute Maximum Ratings

- Maximum Temperatures
Storage Temperature T_{stg} -65~+150 °C
Operating Junction Temperature T_j -65~+150 °C
- Maximum Power Dissipation
Total Power Dissipation ($T_a=25^{\circ}C$) P_{tot} (Note) 200 mW
- Maximum Thermal Resistance625 °C /W
- Maximum Voltages and Currents ($T_a=25^{\circ}C$)
Repetitive Peak Reverse Voltage V_{RRM} 40 V
Continuous Forward Current I_F 200 mA
Repetitive Peak Forward Current($t_p \le 1s, duty\ cycle \le 0.5$)..... 300mA
Non-repetitive Peak Forward Current ($t_p < 10ms, sinusoidal$) I_{FSM} 600 mA

Note: for double diodes, P_{tot} is the total power dissipation of both diodes.

Characteristics ($T_a=25^{\circ}C$)

Characteristic	Symbol	Condition	Min.	Max.	Unit
Reverse Breakdown Voltage	V_{BR}	$I_R=100\mu A$	40	-	V
Forward Voltage (Note 1)	$V_F(1)$	$I_F=1mA$	-	320	mV
	$V_F(2)$	$I_F=40mA$	-	500	mV
	$V_F(3)$	$I_F=100mA$	-	550	mV
Reverse Leakage Current (Note 2)	I_R	$V_R=30V, T_j=25^{\circ}C$	-	200	nA
Diode Capacitance	C_D	$V_R=1V, f=1MHz$	-	10	pF
Reverse Recovery Time	t_{rr}	$I_F=I_R=10mA, R_L=100\Omega$ measured at $I_R=1mA$	-	5	ns

Notes: 1.pulse test, $t_p=380\mu s, duty\ cycle < 2\%$.
2.pulse test, $t_p=5ms, duty\ cycle < 2\%$.

Ordering Information

Device	Package	Shipping	Marking
BAR40S3-0-T1-G	SOT-323 (Pb-free lead plating and halogen-free package)	3000 pcs / Tape & Reel	B4
BAR40AS3-0-T1-G			B7
BAR40CS3-0-T1-G			5C
BAR40SS3-0-T1-G			B8

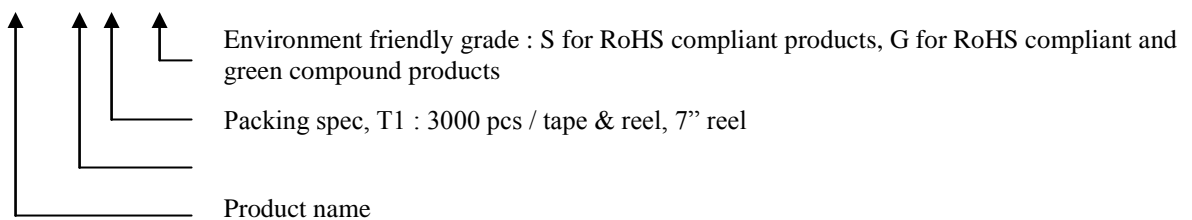

Typical Characteristics

Forward Current vs Forward Voltage

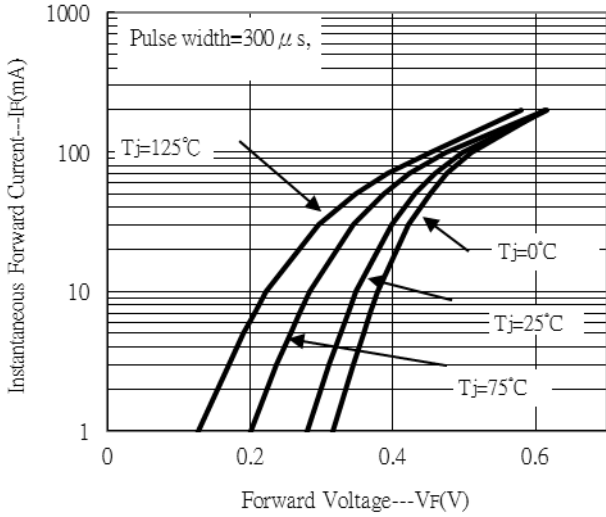

Reverse Leakage Current vs Reverse Voltage

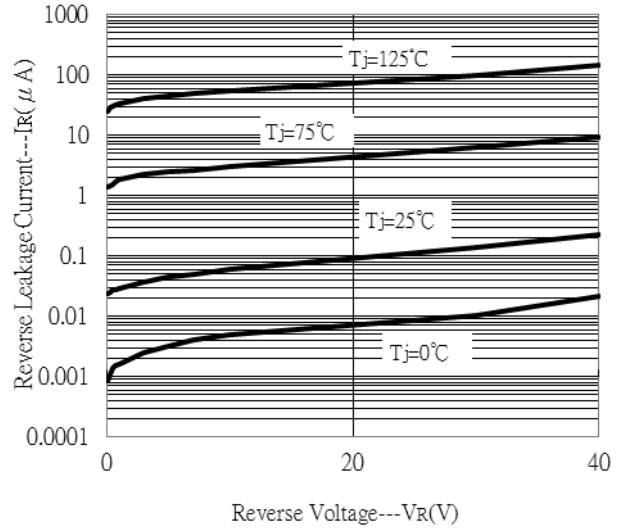

Junction Capacitance vs Reverse Voltage

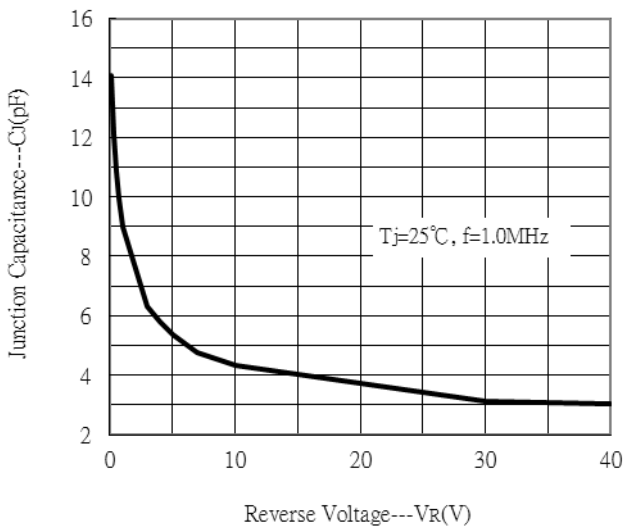

Recommended Footprint

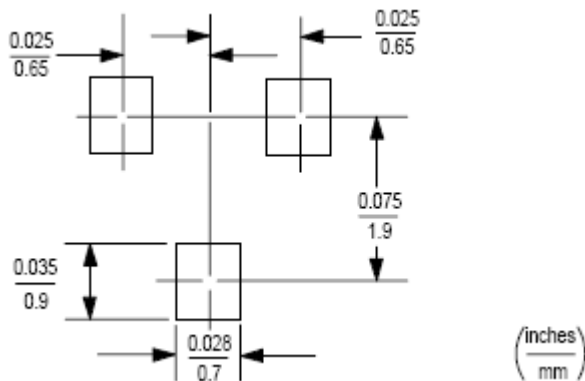

Reel Dimension

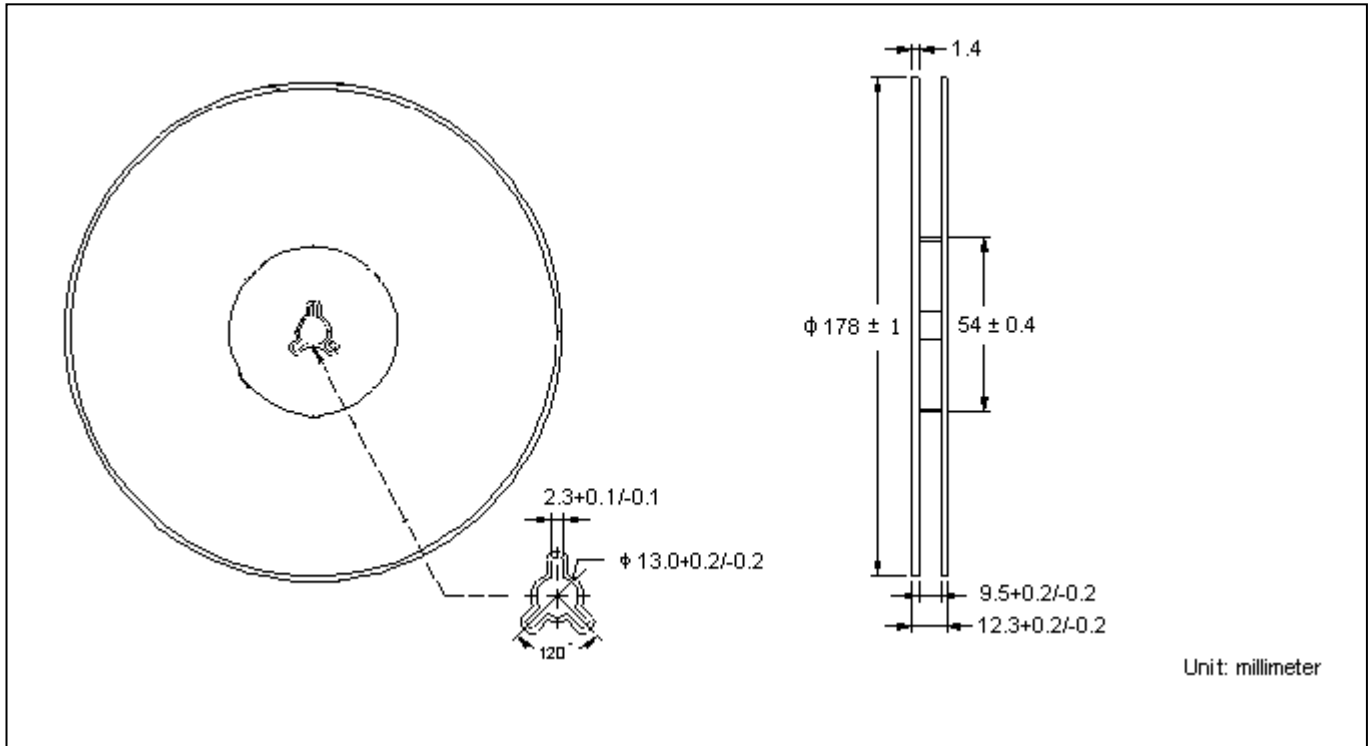

Carrier Tape Dimension

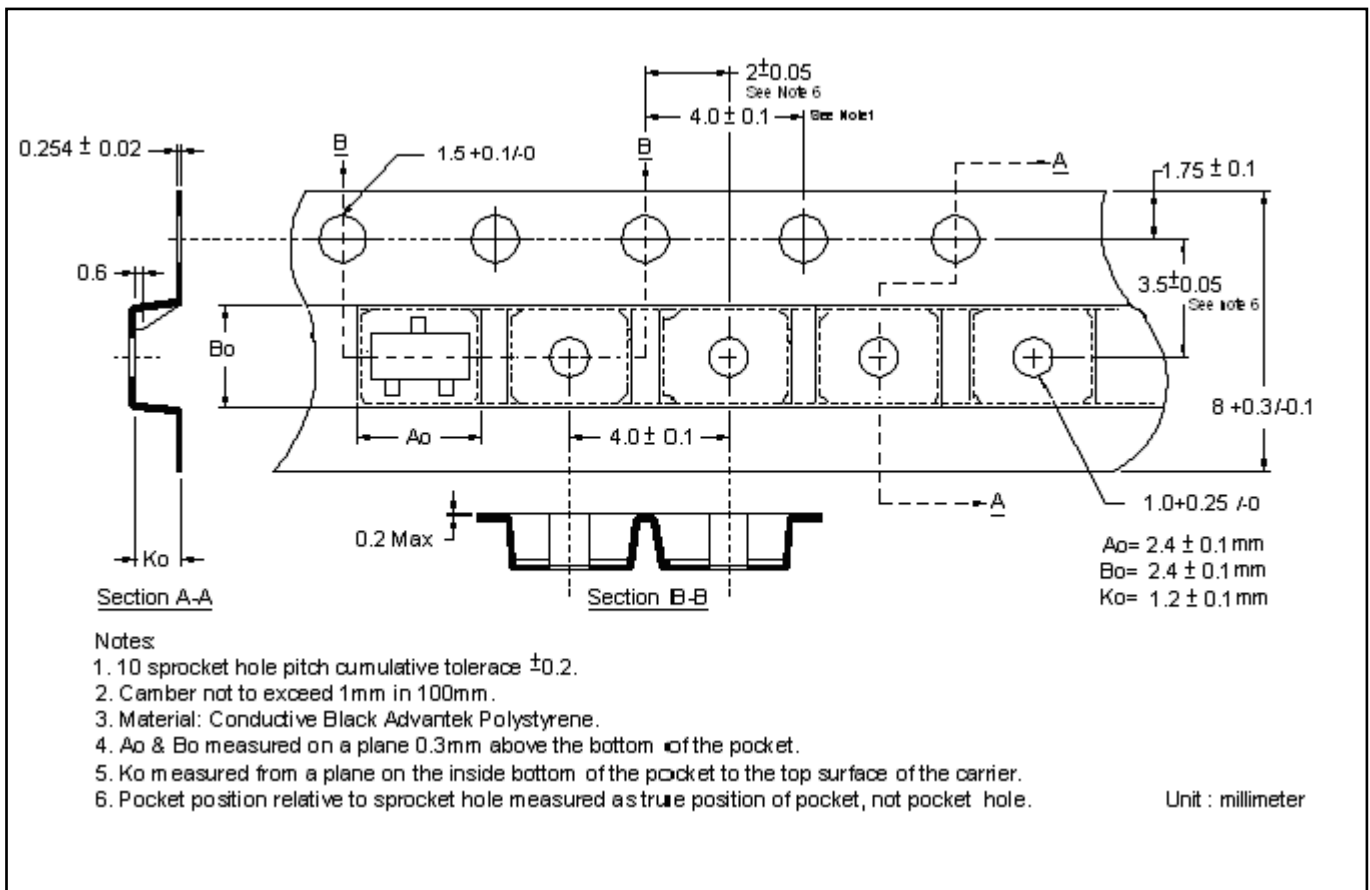

Recommended wave soldering condition

Product	Peak Temperature	Soldering Time
Pb-free devices	260 +0/-5 °C	5 +1/-1 seconds

Recommended temperature profile for IR reflow

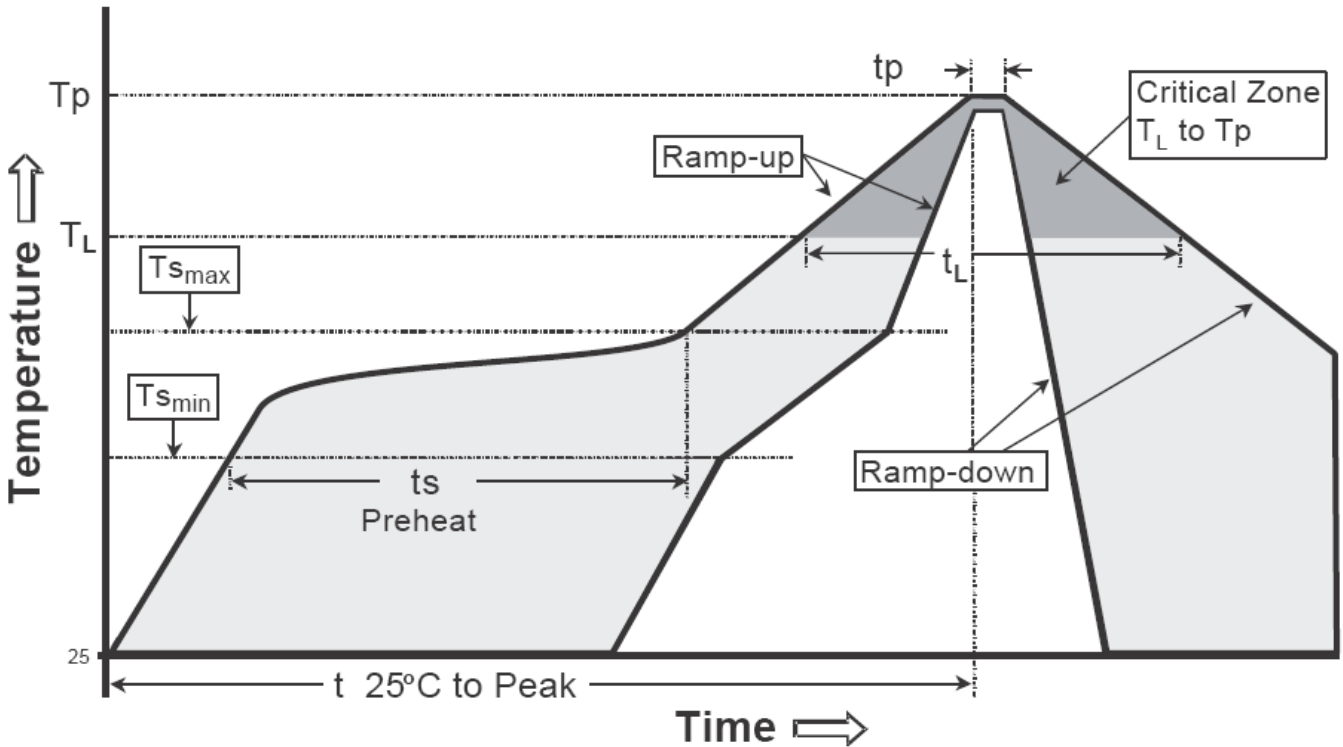

Profile feature	Sn-Pb eutectic Assembly	Pb-free Assembly
Average ramp-up rate (T _{smax} to T _p)	3°C/second max.	3°C/second max.
Preheat		
-Temperature Min(T _{s min})	100°C	150°C
-Temperature Max(T _{s max})	150°C	200°C
-Time(t _{s min} to t _{s max})	60-120 seconds	60-180 seconds
Time maintained above:		
-Temperature (T _L)	183°C	217°C
- Time (t _L)	60-150 seconds	60-150 seconds
Peak Temperature(T _P)	240 +0/-5 °C	260 +0/-5 °C
Time within 5°C of actual peak temperature(tp)	10-30 seconds	20-40 seconds
Ramp down rate	6°C/second max.	6°C/second max.
Time 25 °C to peak temperature	6 minutes max.	8 minutes max.

Note : All temperatures refer to topside of the package, measured on the package body surface.

SOT-323 Dimension

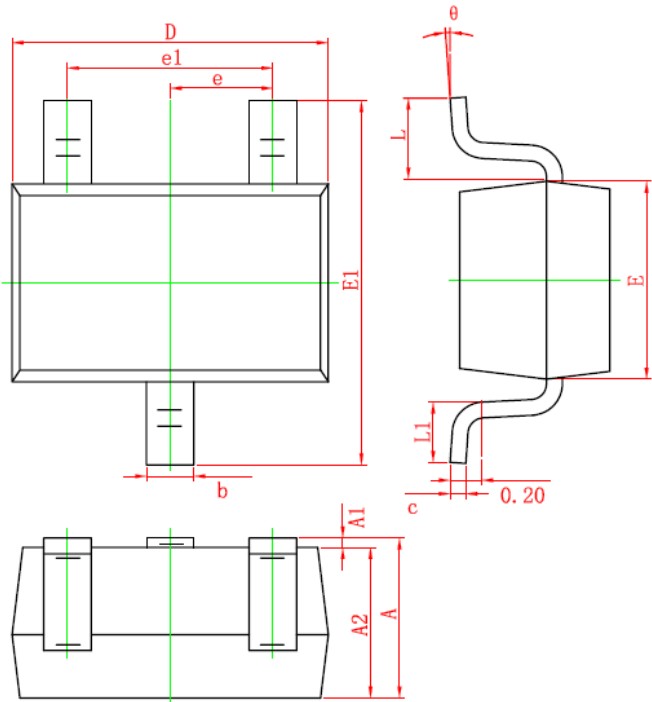

Marking:

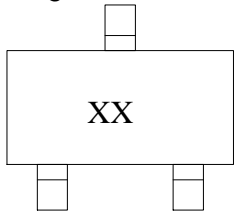
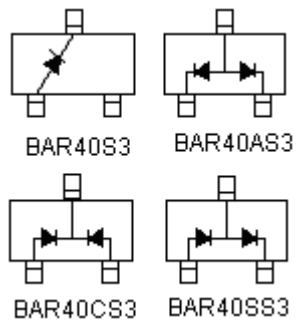

Diagram:



3-Lead SOT-323 Plastic Surface Mounted Package.
CYStek Package Code: S3

- BAR40 S3 : Single Diode (Marking Code B4)
- BAR40AS3 : Common Anode. (Marking Code B7)
- BAR40CS3 : Common Cathode. (Marking Code 5C)
- BAR40SS3 : Series Connected. (Marking Code B8)

DIM	Inches		Millimeters		DIM	Inches		Millimeters	
	Min.	Max.	Min.	Max.		Min.	Max.	Min.	Max.
A	0.900	1.100	0.035	0.043	E1	2.150	2.450	0.085	0.096
A1	0.000	0.100	0.000	0.004	e	0.650	TYP	0.026	TYP
A2	0.900	1.000	0.035	0.039	e1	1.200	1.400	0.047	0.055
b	0.200	0.400	0.008	0.016	L	0.525	REF	0.021	REF
c	0.080	0.150	0.003	0.006	L1	0.260	0.460	0.010	0.018
D	2.000	2.200	0.079	0.087	θ	0°	8°	0°	8°
E	1.150	1.350	0.045	0.053					

Notes: 1.Controlling dimension: millimeters.
 2.Maximum lead thickness includes lead finish thickness, and minimum lead thickness is the minimum thickness of base material.
 3.If there is any question with packing specification or packing method, please contact your local CYStek sales office.

Material:

- Lead: Pure tin plated.
- Mold Compound: Epoxy resin family, flammability solid burning class: UL94V-0.

Important Notice:

- All rights are reserved. Reproduction in whole or in part is prohibited without the prior written approval of CYStek.
- CYStek reserves the right to make changes to its products without notice.
- CYStek **semiconductor products are not warranted to be suitable for use in Life-Support Applications, or systems.**
- CYStek assumes no liability for any consequence of customer product design, infringement of patents, or application assistance.